



**General Information**

Definitions and Design Considerations ..... W-CR-2

**Combination Assembly Recommendations and Limitations**

Typical Sealant..... W-CR-4

Single-Unit Opening ..... W-CR-4

Two-Way Window Combinations

    Horizontal Windows ..... W-CR-5

    Vertical Windows ..... W-CR-6

    Vertical Stacking Intermediate Support Details..... W-CR-7

Three-Way Window Combinations..... W-CR-9

Four-Way Window Combinations..... W-CR-10

    Weight Limitations Over Operable Awning Windows ..... W-CR-11

Door and Window Combinations

    Door and Door/Window Recommendations..... W-CR-12

    Weight Limitations of Transoms Over Doors ..... W-CR-13

    Door and Window Combination Recommendations..... W-CR-14

    Mullion Reinforcement Cross Sections ..... W-CR-15

Sample Calculations ..... W-CR-16

Mullion Load Charts Introduction ..... W-CR-20

Mullion End Anchor Capacity ..... W-CR-21

    Factory Assembled—Two-Way Joint Window ..... W-CR-22

    Factory Assembled—Three-Way Joint Window ..... W-CR-24

    Factory Assembled—Four-Way Joint Window ..... W-CR-26

    Factory Assembled—Two-Way Joint Door to Transom ..... W-CR-28

    Factory Assembled—Three-Way Joint Door to Windows ..... W-CR-30

    Non-Factory Assembled—Two-Way Joint Window ..... W-CR-31

    Non-Factory Assembled—Three-Way Joint Window ..... W-CR-33

    Non-Factory Assembled—Four-Way Joint Window ..... W-CR-35

    Non-Factory Assembled—Two-Way Joint Door ..... W-CR-37

    Non-Factory Assembled—Two-Way Joint Door to Transom ..... W-CR-39

    Factory Assembled—Three-Way Joint Door and Two Transoms ..... W-CR-41

The information published in this document is believed to be accurate at the time of publication. However, because we are constantly working to improve our products, content is subject to change without notice. Some content may not reflect the most current product offering, but installation concepts still apply. Consult your local Pella representative for up-to-date product information.



This section explores the opportunities, requirements and limitations related to joining various combinations of standard Pella® windows and doors.

### IMPORTANT:

Determining and meeting the structural load requirements and design of the rough opening is the responsibility of the architect or engineer.

Window and door frame systems are not designed to support additional elements or components of the building wall system.

Specific accessories and construction details must address the various conditions that are critical for the proper design of a horizontal combination of windows (ribbon windows) and vertical combination (stacked windows) such as:

- Proper flashing
- Control joints to accommodate expansion and contraction
- Intermediate structural support
- Mullion reinforcing end anchorage
- Rough opening wall construction to accept loads transferred from window combination.

Definitions:	
Combination	An assembly formed by two or more separate windows, window composites, or doors whose frames are mullied together using a combination joining mullion or reinforcing mullion.
Combination (Joining) Mullion	A horizontal or vertical member formed by joining two or more individual window or door units together without a mullion stiffener.
Reinforcing Mullion	A horizontal or vertical member with an added continuous mullion stiffener and joining two or more individual windows or doors along the sides of the mullion stiffener.
Composite	A window or door consisting of two or more sash in one frame utilizing an integral mullion.
Integral Mullion	A horizontal or vertical member which is bounded at either end or both ends by a crossing frame member.

### Design Considerations

The following steps are provided as a guide to assist in properly integrating Pella products and accessories into combination assemblies. Sample calculations are based on these steps.

#### 1. Determine the overall size and configuration of the combination

Below, the basic combination assembly types are shown. The dashed line indicates where a spread mullion or reinforcing mullion may be required. Windows/doors within the combination can be fixed or venting.

#### 2. Determine the required wind load (design pressure)

The design pressure is the wind load pressure that the window assembly is to withstand. The design pressure should be determined by the project engineer or architect but can also be provided by the local code official.

ASCE 7-05, Minimum Design Loads for Buildings and Other Structures contains the generally accepted method for determining design pressure for components and cladding based on building size and shape, geographical location, topographical factors, building use and location on the building's surface.

#### 3. Determine if the individual windows and/or doors within the combination meet the required design pressure

Each Pella window and door is rated to withstand a certain level of wind loading. The design pressure determined in step 2 should also be used to specify window and door performance. The Product Performance Section provides more detailed information on the relationship between design pressure and the performance class and grade ratings used to specify window/door performance. See the Products section of the Architectural Design Manual to ensure that each window or door can withstand the required design wind load pressure.

#### 4. Determine if the glazing within each product can withstand the required design pressure

ASTM E 1300-04 requires that glazing be of adequate strength to resist excessive deflection under wind load. The Glazing Performance Charts in the Performance Section, contains glazing design pressure charts. Select the appropriate glazing type and/or thickness required to meet the design pressure. Pella sales representatives can utilize the Pella quoting system to determine the glazing design pressure of a specific product.



### 5. Determine if the combination will be factory assembled or non-factory assembled

Use the combination size tables found in this section to determine if the combination is available factory assembled. If the combination is not found in the size tables, it is not available assembled from the factory. In this case, the non-factory reinforcing mullion table must be used. Also consider factors such as installation method, handling and accessibility to the opening. Conditions specific to the project may require that a combination be assembled in the opening, or separated into multiple combinations.

### 6. Determine the requirement for spread or reinforcing mullions

Placing windows and doors in combination creates joints or mullions that may need reinforcing. Spread mullions can also be utilized to achieve an aesthetic element. In order to ensure that a given combination will withstand the design pressure determined in step 2, use the reinforcing mullion tables in this section. These tables are organized by joint type and assembly type (factory vs. non-factory assembled). Use the graphical representation of each joint type to determine which joint type(s) are contained within the combination. The reinforcing tables consider structural performance only. Performance class and grade ratings apply to single units only. See the Size and Performance Data page within each product section for more information. Also consider the tables for dead load when placing windows or transoms over awnings or doors.

### 7. Determine the appropriate mullion reinforcing

The reinforcing mullion tables in this section are intended to aid in the selection of reinforcing members to help the combination resist the forces placed upon it by wind loads and loads caused by other units within the combination. The following pages provide instructions on how to use the tables. By entering the tables with the joint's mullion length and the widths of the adjacent units, choose any reinforcing mullion option at or below the coordinate given on the table. If spread mullions are desired for aesthetic reasons, use the tables to determine if the spread mullion meets or exceeds the required design pressure..

### 8. Determine if subsill is required

Subsill systems that weep incidental moisture to the exterior are recommended for water management in openings where the potential for water infiltration is increased and may not be adequately managed by the building weather barrier, flashings and drainage system. Sample conditions include, but are not limited to: increased level of exposure due to multi-story construction, high weather exposure, recaulking would be difficult or unlikely, non-standard installation methods, or when there are multiple units joined within the opening.

### 9. Determine rough opening size data

This section contains recommendations for each combination assembly type. Use the recommendations in this section to determine rough opening clearance dimensions as well as if subsill, frame expander, or expansion mullion accessories are required. More information on Pella accessories can be found in Installation Accessories and Installation Detail Sections of this volume. Add any applicable frame, accessory, and mullion dimensions to arrive at the overall opening dimensions.

## Typical Combination Types

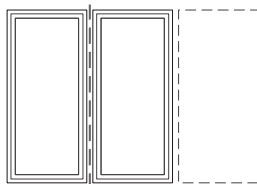

Horizontal Windows



Vertical Windows

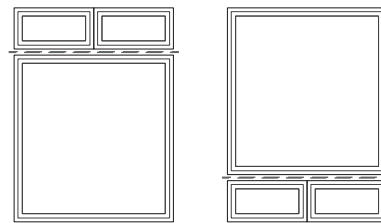

Three Way Windows

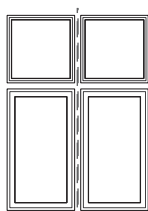

Four Way Windows

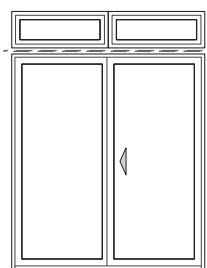

Three Way Door Transom

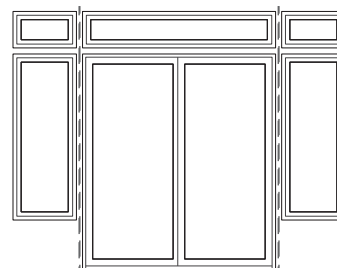

Four Way Door



Typical Sealant Recommendations

Interior and Exterior Sealant Placement Detail

TYPICAL EXTERIOR PERIMETER SEALANT DETAIL

TYPICAL INTERIOR PERIMETER SEALANT DETAIL

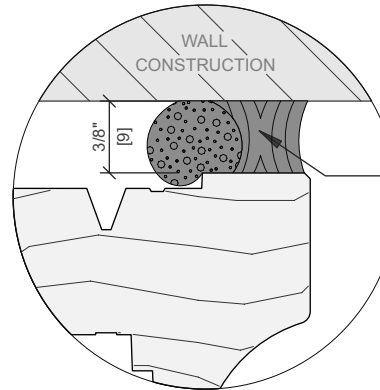
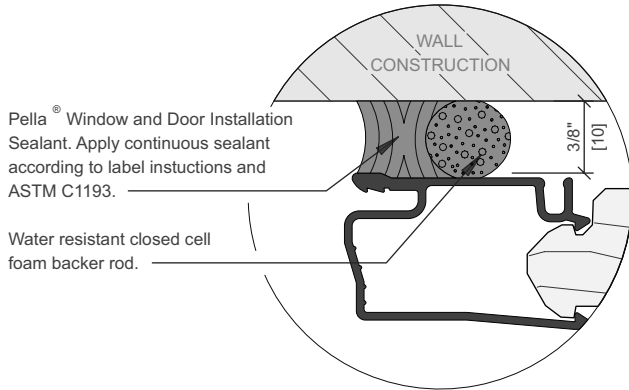

Pella® Window and Door Installation Sealant. Apply continuous sealant according to label instructions and ASTM C1193.

Water resistant closed cell foam backer rod.

Water resistant backer rod and sealant is recommended on interior for commercial installations.  
or  
For use in most residential applications; apply continuous 1" bead of Low expansion, low pressure polyurethane insulating window and door foam sealant to create full interior seal. (Do NOT use high pressure or latex foam.)

When applying siding, brick veneer or other exterior finish material, leave adequate space between the window frame and the material for sealant. Refer to the illustration that corresponds to your finish material.

**Note:** The sealant details shown are standard recommendations from the sealant industry. Contact your sealant supplier for recommendations and instructions for these and any other applications.

Single-Unit Opening Recommendations

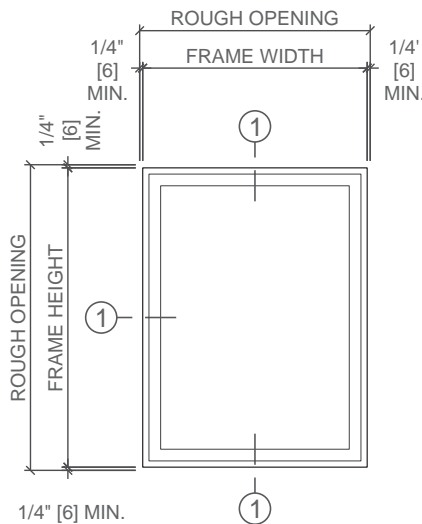

- ① To determine window openings for typical installations, add 3/4" to frame width and 3/4" to frame height.
- For large size units, out of plumb opening, and/or in masonry construction, the need for additional jamb clearances should be reviewed.
- Typical installation details and accessories are shown in the Installation Details and Installation Accessories sections.
- Determine if unit performance meets design requirements. Unit performance class and grade are in each product section.



# Clad-Wood Combinations

## Horizontal Window Combinations - Two-Way Joint Recommendations

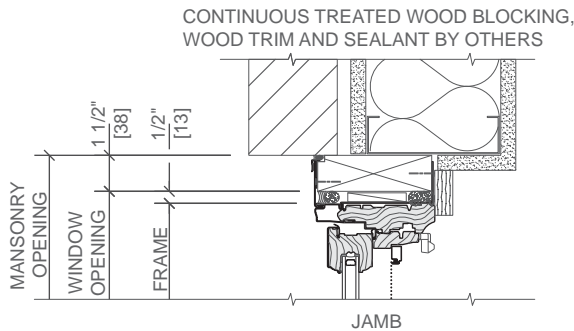
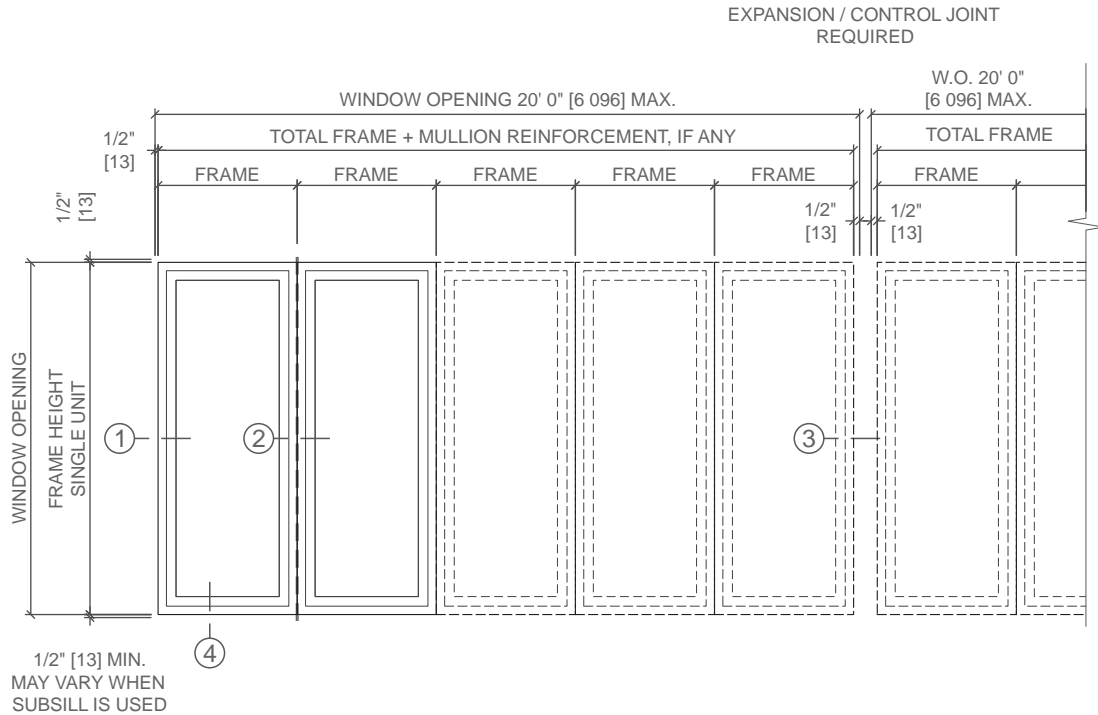

FRAME EXPANDER RECEPTOR #72A7

FRAME EXPANDER #47D5

BACKER ROD AND SEALANT BY OTHERS

SHIM AND PLUMB UNITS AS REQUIRED

INSTALLATION CIPS #5071 @ 18" (457) O.C.

• GREAT STUFF® PRO WINDOW AND DOOR INSULATING FOAM BY DOW CHEMICAL COMPANY.

Apply a continuous 1" bead of insulating foam to provide a full interior seal.

NOTE: APPLY CONTINUOUS BEAD OF SEALANT TO INSIDE CORNER OF FRAME EXPANDER BEFORE INSTALLING TO UNIT

### These recommendations apply to a typical horizontal combination of any vent or fixed unit.

Refer to single-unit opening recommendations in addition to the following:

- ① Minimum 3/8" clearance on smaller openings.
- ② Check if reinforcing mullion is required due to specified wind loading. Standard combination (joining) and reinforcing mullions are shown on the mullion load charts later in this section.
- ③ Expansion/control mullion is required every 20' maximum. Minimum 1/2" clearance is recommended at each jamb for openings greater than 10' in masonry openings.
- ④ Subsill systems that weep incidental moisture to the exterior are recommended for water management in openings where the potential for water infiltration is increased and may not be adequately managed by the building weather barrier, flashings and drainage system. Sample conditions include, but are not limited to: increased level of exposure due to multi-story construction, high weather exposure, re-caulking would be difficult or unlikely, non-standard installation methods, or when there are multiple units joined within the opening.

- Jamb detail shown above is suggested for combinations from 15' to 20' wide to accommodate discrepancies in construction, growth of unit assemblies and expansion movement.



Vertical Window Combinations - Two-Way Joint Recommendations

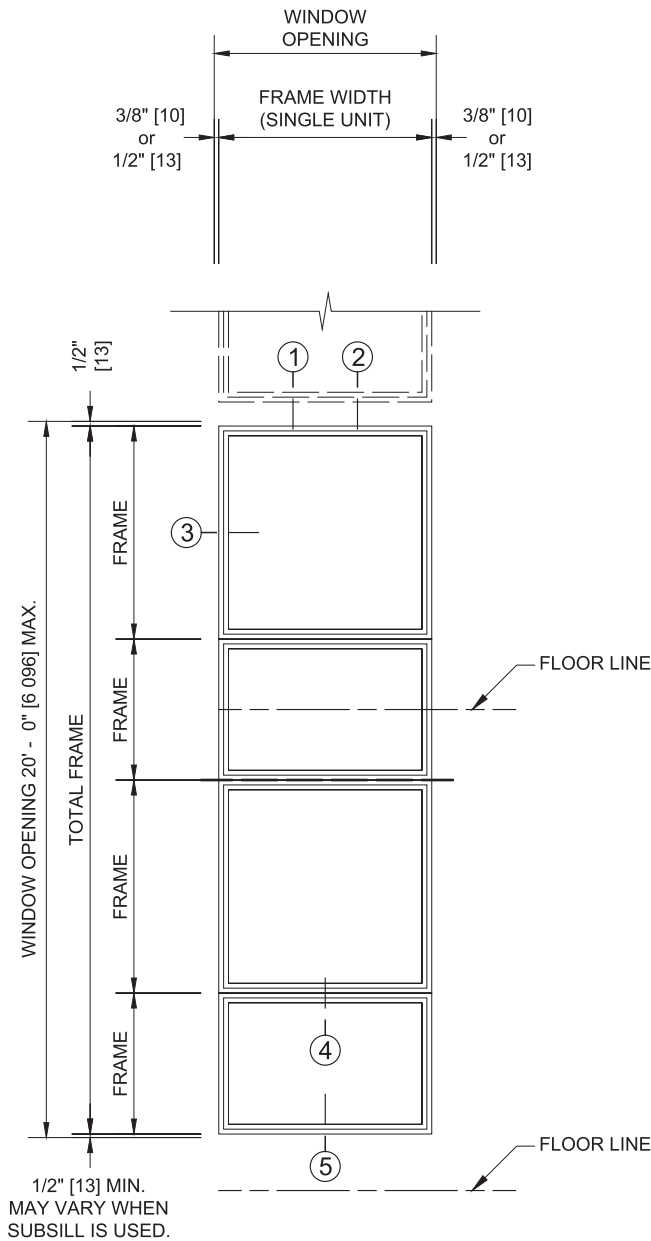

These recommendations apply to a typical vertical stacking of vent or fixed units of the same width (4' 11" max.) to a maximum height of 20' without intermediate support.

Refer to single-unit recommendations in addition to the following:

- ① When window opening height is 12' to 20', see suggested head detail below to accommodate discrepancies in construction, floor and ceiling deflection, growth of unit assemblies and expansion movement. Check local code requirements when stacking units past floor line.
- ② Intermediate dead load support is required in accordance with recommendations on the Weight Limitations of Transoms Over Doors page, or at least every 20'. See the following pages for optional suggested details.
- ③ 1/2" clearance is recommended at each jamb in masonry construction and/or when window opening height is 10' or greater.
- ④ Check if reinforcing mullion is required due to specified wind loading and dead load (See Sample Calculations and Weight Limitations Over Windows).
- ⑤ Subsill systems that weep incidental moisture to the exterior are recommended for water management in openings where the potential for water infiltration is increased and may not be adequately managed by the building weather barrier, flashings and drainage system. Sample conditions include, but are not limited to: increased level of exposure due to multi-story construction, high weather exposure, recaulking would be difficult or unlikely, non-standard installation methods, or when there are multiple units joined within the opening.

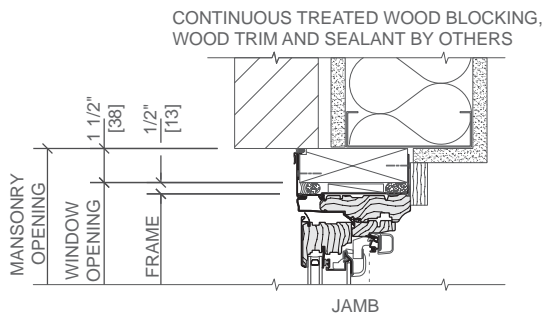

NOTE: APPLY CONTINUOUS BEAD OF SEALANT TO INSIDE CORNER OF FRAME EXPANDER BEFORE INSTALLING TO UNIT

**FRAME EXPANDER RECEPTOR #72A7**

**FRAME EXPANDER #47D5**

**BACKER ROD AND SEALANT BY OTHERS**

**SHIM AND PLUMB UNITS AS REQUIRED**

**INSTALLATION CIPS #5071 @ 18" (457) O.C.**

- GREAT STUFF™ PRO WINDOW AND DOOR INSULATING FOAM BY DOW CHEMICAL COMPANY. Apply a continuous 1" bead of insulating foam to provide a full interior seal.



Vertical Stacking Intermediate Support Details

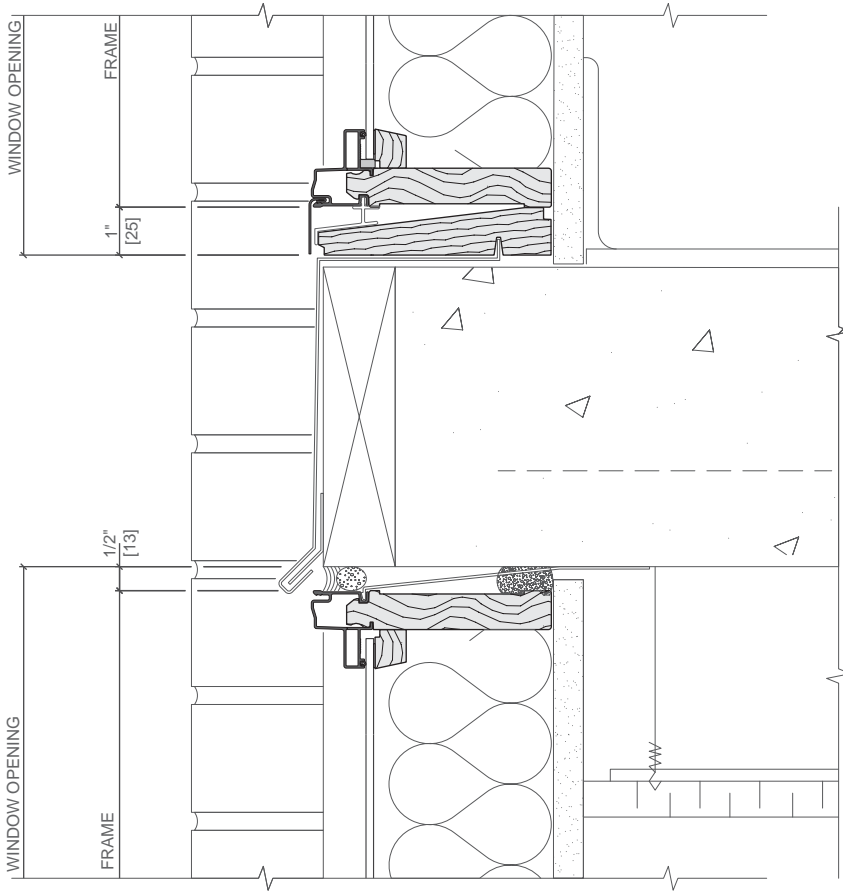

INTERMEDIATE SUPPORT DETAIL ON FLOOR SLAB

SUBSILL #4049

SUBSILL CLIP #7366

1" FRAME EXPANDER #47D5

CUSTOM 0.5" (1.27) BREAK METAL

FRAME EXPANDER RECEPTOR #72A7

PERIMETER BACKER ROD AND SEALANT TYPICAL

NOTE: DO NOT SEAL OPEN SPACE AT BOTTOM OF 1" FRAME EXPANDER.

INSTALLATION CIPS #5071 @ 18" (457) O.C.

INSULATION AND VAPOR BARRIER AS REQUIRED BY OTHERS

- GREAT STUFF™ PRO WINDOW AND DOOR INSULATING FOAM BY DOW CHEMICAL COMPANY.

Apply a continuous 1" bead of insulating foam to provide a full interior seal.

NOTE: Depending upon type of construction and opening size, additional head clearances may be required.

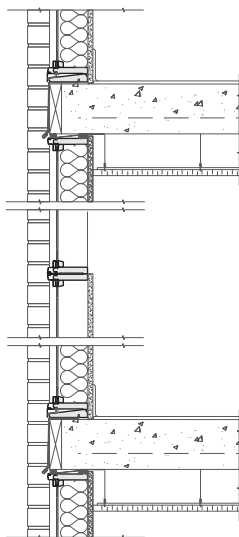

TYPICAL JOINING MULLION @ CEILING LINE

TYPICAL JOINING MULLION @ WINDOW SILL

INTERMEDIATE SUPPORT ON FLOOR SLAB

WALL SECTION



# Clad-Wood Combinations

## Vertical Stacking Intermediate Support Details

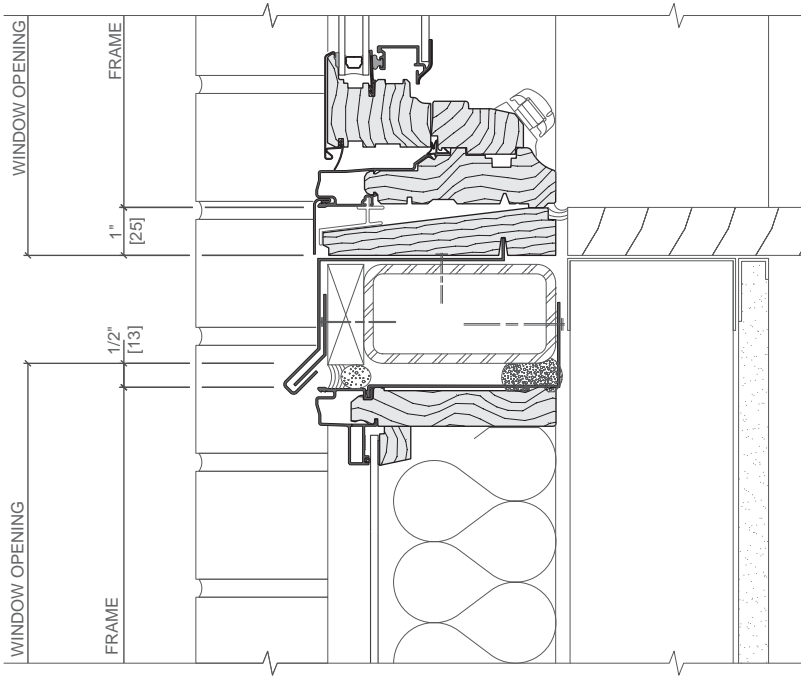

INTERMEDIATE SUPPORT DETAIL @ WINDOW SILL

- SUBSILL #4049
- SUBSILL CLIP #7366
- 1" FRAME EXPANDER #47D5
- WOOD TRIM BY OTHERS
- STRUCTURAL STEEL TUBE BY OTHERS ANCHOR @ JAMBS
- CONTINUOUS INTERIOR PERIMETER FOAM SEALANT
- INSTALLATION CIPS #5071 @ 18" (457) O.C.
- INSULATION AND VAPOR BARRIER AS REQUIRED BY OTHERS
- GREAT STUFF<sup>®</sup> PRO WINDOW AND DOOR INSULATING FOAM BY DOW CHEMICAL COMPANY. Apply a continuous 1" bead of insulating foam to provide a full interior seal.

NOTE: Apply a protective coating to separate aluminum from adjacent metals that may promote galvanic corrosion. All screws and anchors attaching aluminum to steel must be stainless steel.

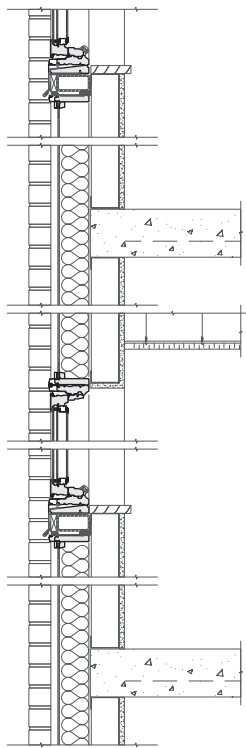

INTERMEDIATE SUPPORT @ WINDOW SILL

FLOOR SLAB

TYPICAL JOINING MULLION @ CEILING LINE

INTERMEDIATE SUPPORT @ WINDOW SILL

FLOOR SLAB

WALL SECTION





## Three-Way Window Combination Recommendations

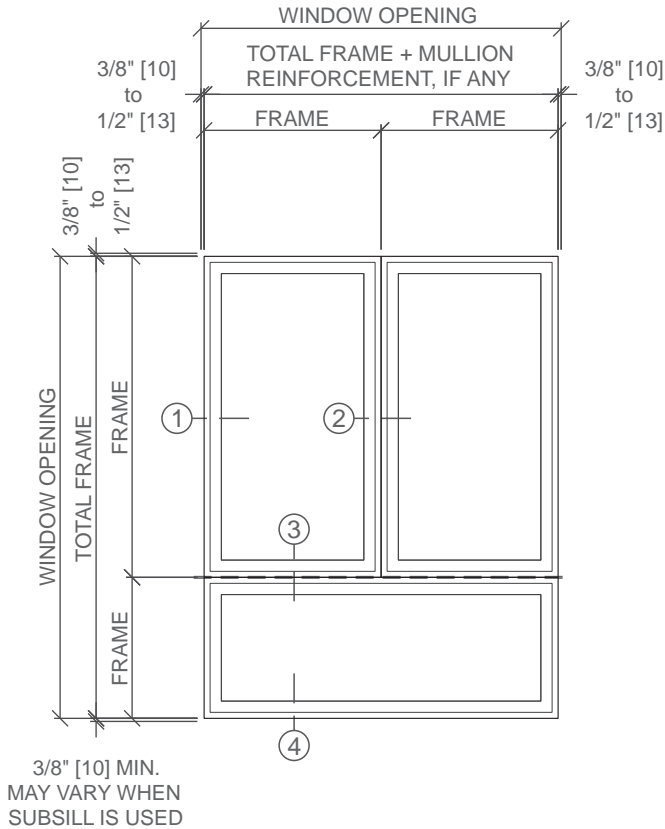

These recommendations apply to a typical grouping of any two vent or fixed units over one fixed unit that forms a three-way mullion intersection.

Refer to single-unit opening recommendations in addition to the following:

- ① 1/2" clearance is recommended at each jamb in masonry construction and/or when window opening height is 10' or greater.
- ② Check if reinforcing mullion is required due to specified wind loading.
- ③ If lower unit is venting, horizontal reinforcing mullion may be required to carry weight of upper units. Contact your local Pella sales representative for specific applications. See Weight Limitations Over Windows in this section.
- ④ Subsill systems that weep incidental moisture to the exterior are recommended for water management in openings where the potential for water infiltration is increased and may not be adequately managed by the building weather barrier, flashings and drainage system. Sample conditions include, but are not limited to: increased level of exposure due to multi-story construction, high weather exposure, recaulking would be difficult or unlikely, non-standard installation methods, or when there are multiple units joined within the opening.



## Clad-Wood Combinations

### Four-Way Window Combination Recommendations

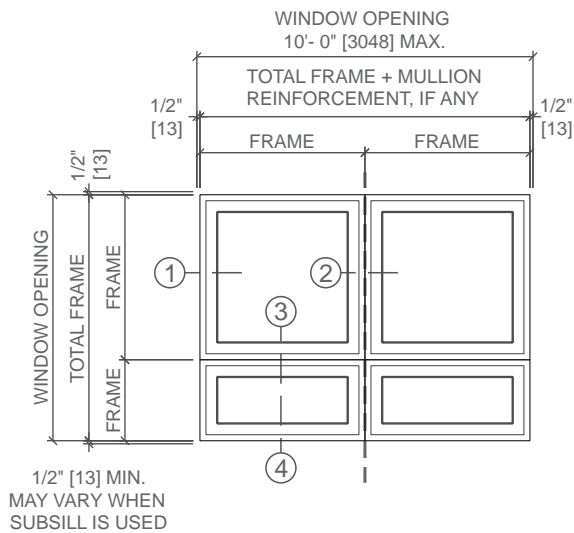

These recommendations apply to a typical grouping of any combination of window units that form a four-way mullion intersection.

Refer to single-unit opening recommendations in addition to the following:

- ① 1/2" clearance is recommended at each jamb in masonry construction and/or when window opening height or width is 10' or greater.
- ② All four-way mullion intersections require reinforcing mullion in one direction (either vertically or horizontally). See mullion load chart pages later in this section.
- ③ Check combination (joining) mullion limitation for specified wind loading. Combination (joining) and reinforcing mullions are shown on the mullion load chart pages.
- ④ Subsill systems that weep incidental moisture to the exterior are recommended for water management in openings where the potential for water infiltration is increased and may not be adequately managed by the building weather barrier, flashings and drainage system. Sample conditions include, but are not limited to: increased level of exposure due to multi-story construction, high weather exposure, recaulking would be difficult or unlikely, non-standard installation methods, or when there are multiple units joined within the opening.

If lower unit is venting, horizontal reinforcing mullion may be required to carry weight of upper units. See Weight Limitations Over Windows information in this section.



# Clad-Wood Combinations

## Weight Limitations Over Windows

**Condition 1:** For situations with single-wide stacking of sash and frame product over awning or clad fixed frame direct set, see notes on page W-CR-12.

**Condition 2:** For situations with multiple window units or single clad fixed frame direct set over one unit, check mullion requirements as follows:

- Step 1** Determine reinforcing mullion for wind load by following the steps from page 16 through 19.
- Step 2** Determine weight of upper units. (See calculation below.)
- Step 3** Using the weight calculated and the unit width go to the charts below. Determine the appropriate reinforcing mullion to resist dead load from upper units.
- Step 4** Review the appropriate mullion wind load table to determine the required reinforcement for wind resistance.
- Step 5** Select the mullion capable of withstanding dead load and wind load.

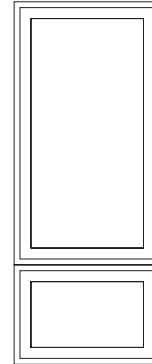

Condition 1

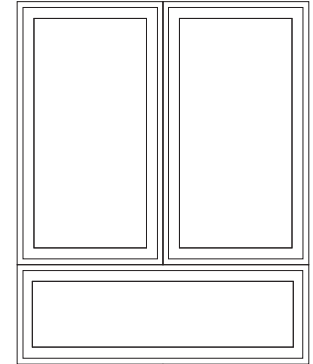

Condition 2

Determine the intersection of the unit width and the weight of units above. The letter at the intersection is the minimum structural support that can be used. Any support member to the right and below of that intersection can also be used.

**To Calculate:**

**Upper Unit Weight**

Total weight = Frame weight + Glass weight

**Glass Weight (lbs)**

Glass width (inches) x Glass height (inches) x Total glass thickness (inches) ÷ 11

**Frame Weight**

Clad Frame or Circlehead = 1.45 lbs. per lineal foot

Clad Casement Fixed = 1.50 lbs. per lineal foot

**Factory Assembled**

Weight (lbs)	Unit Width (inches)						
	35	40	45	50	55	59	
60	A	A	A	C	C	C	
80	A	A	C	C	C	D	
100	A	C	C	C	D	D	
120	A	C	C	C	D	D	
140	C	C	C	D	D	D	
160	C	C	C	D	D	D	
180	C	C	D	D	D	E	
200	C	C	D	D	D	E	
220	C	C	D	D	E	E	
240	C	C	D	D	E	E	
260	C	D	D	D	E	E	
280	C	D	D	E	E	E	
300	C	D	D	E	E	E	
320	C	D	D	E	E	E	
340	C	D	D	E	E	G	<b>Reinforcing mullion</b>
360	C	D	D	E	E	G	<b>A 1" x 4-3/8" Wood</b>
380	D	D	E	E	E	G	<b>C 1-1/2" x 4-3/8" Wood</b>
400	D	D	E	E	E	G	<b>D 2" x 4-3/8" Wood</b>
420	D	D	E	E	E	G	<b>E 2-1/2" x 4-3/8" Wood</b>
440	D	D	E	E	E	G	<b>G 3" x 4-3/8" Wood</b>
460	D	D	E	E	E	G	
480	D	D	E	E	E	G	
500	D	D	E	E	E	G	

**Non-Factory Assembled**

Weight (lbs)	Unit Width (inches)						
	35	40	45	50	55	59	
60	AA	AA	AA	AA	AA	JJ	
80	AA	AA	AA	AA	AA	JJ	
100	AA	AA	AA	JJ	JJ	JJ	
120	AA	AA	JJ	JJ	JJ	JJ	
140	AA	AA	JJ	JJ	JJ	JJ	
160	AA	AA	JJ	JJ	JJ	JJ	
180	AA	JJ	JJ	JJ	JJ	JJ	
200	AA	JJ	JJ	JJ	JJ	JJ	
220	AA	JJ	JJ	JJ	JJ	JJ	
240	AA	JJ	JJ	JJ	JJ	JJ	
260	JJ	JJ	JJ	JJ	JJ	JJ	
280	JJ	JJ	JJ	JJ	JJ	JJ	
300	JJ	JJ	JJ	JJ	JJ	CC	
320	JJ	JJ	JJ	JJ	JJ	CC	
340	JJ	JJ	JJ	JJ	JJ	CC	
360	JJ	JJ	JJ	JJ	CC	CC	<b>Reinforcing mullion</b>
380	JJ	JJ	JJ	JJ	CC	KK	<b>AA 2" x 4" Wood Flat</b>
400	JJ	JJ	JJ	JJ	CC	KK	<b>JJ 16 ga 1-5/8" x 3-5/8" Nested Steel Stud</b>
420	JJ	JJ	JJ	JJ	CC	KK	<b>CC 2-2 x 4" Wood Flat</b>
440	JJ	JJ	JJ	JJ	CC	KK	<b>KK 3-2" x 4" Wood on End</b>
460	JJ	JJ	JJ	JJ	CC	KK	
480	JJ	JJ	JJ	CC	KK	KK	
500	JJ	JJ	JJ	CC	KK	KK	

- When awnings with butt hinges are below multiple units, add the weight of the awning to the total weight. The head of the awning must be screwed to the horizontal reinforcement.
- Check tables at the end of this section for availability of factory-assembled combinations.
- Non-Factory assembled – all units must be shimmed at the jambs below the reinforcing member.
- If weight of upper unit exceeds 500 pounds, contact your local Pella sales representative.



## Clad-Wood Combinations

### Door and door / window Combination Recommendations

These recommendations apply to a typical combination of any vent or fixed door and door units which form a mullion intersection.

1. 1/2" rough opening clearance is recommended at the head of all doors.
2. 1/2" clearance is also recommended at each jamb in masonry construction or large combinations.
3. Reinforcing mullion is always required at the vertical mullion between the window and door in window and door groupings.
4. When putting transoms over OXXO sliding doors horizontal reinforcing mullion is required between the door head and transoms so that the transom weight doesn't deflect the door frame. See the mullion load charts for reinforcing requirements.
5. Horizontal reinforcing mullion may be required above venting doors to carry weight of upper units. See Weight Limitations of Transoms Over Doors information in this section.
6. All door combinations in a high traffic / commercial application require structural reinforcement at jambs.
7. Doors with closers require a structural header for attachment of the closer hardware. Do not rely on the door frame itself for anchorage (surface mounted closers are recommended).

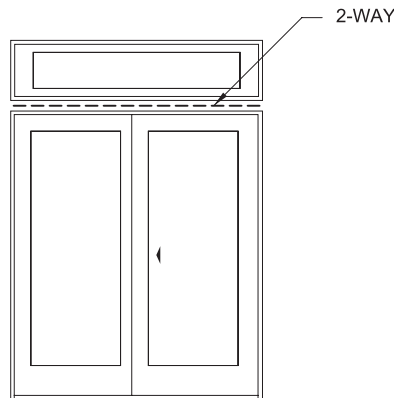

Door / Transom

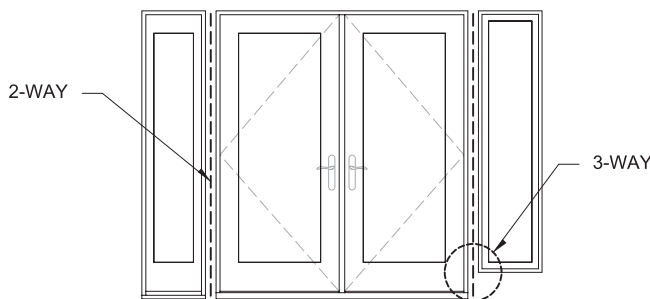

Door / Sidelight / Window

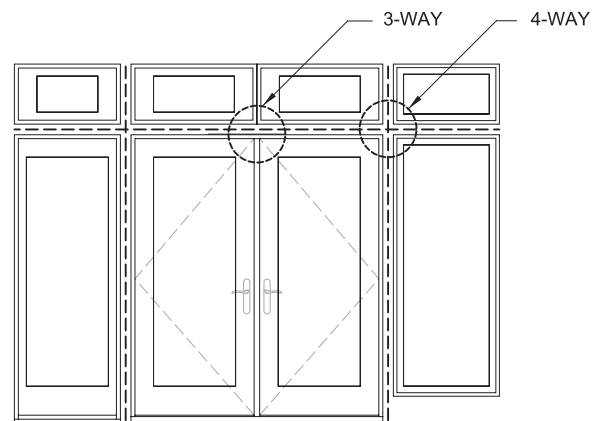

Door / Sidelight / Transom

Continued on next page



Weight Limitations of Transoms Over Doors

For situations with multiple units or single clad fixed frame over one unit, check mullion requirements as follows:

- Step 1** Determine reinforcing mullion for wind load by following the steps from page 16 through 19.
- Step 2** Determine weight of upper units. (See calculation below.)
- Step 3** Using the weight calculated and the unit width go to the charts below. Determine the appropriate reinforcing mullion to resist dead load from upper units.
- Step 4** Review the appropriate mullion wind load table to determine the required reinforcement for wind resistance (found later in this section).
- Step 5** Select the mullion capable of withstanding dead load and wind load.

**To Calculate:**

**Upper Unit Weight**

Total weight = Frame weight + Glass weight

**Glass Weight (lbs)**

Glass width (inches) x Glass height (inches) x Total glass thickness (inches) ÷ 11

**Frame Weight**

Clad Frame or Circlehead = 1.45 lbs. per lineal foot

Clad Casement Fixed = 1.50 lbs. per lineal foot

**Transoms Over Clad Sliding Doors**

Door Configuration	Transom Condition	Mullion Reinforcement (see next page for details)	Maximum Weight of Transom(s)
All Single Doors All OX, XO Doors	Single or Multiple	A	500 lbs./panel for 6' 8" tall doors
			300 lbs./panel for 8' tall doors
OXO and OXXO 96" – 144"	Multiple	B	30 lbs.
		C	210 lbs.
		D	500 lbs.
OXXO 145" – 189"	Multiple	B	12 lbs.
		C	90 lbs.
		D	200 lbs.

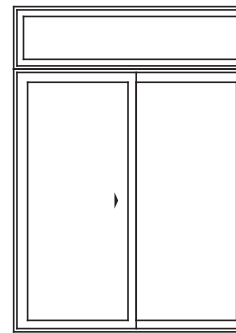

Single Unit  
Transom Condition

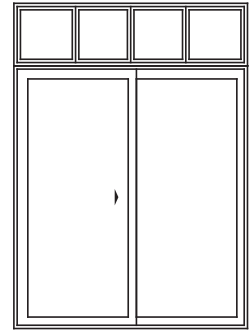

Multiple Unit  
Transom Condition  
(Two or more units)

**Transoms Over French Doors**

Door Configuration	Transom Condition	Mullion Reinforcement (see next page for details)	Maximum Weight of Transom(s)
All Single Doors All AF or FA Doors	Single or Multiple	A	500 lbs./panel for 6' 8" tall doors
			300 lbs./panel for 8' tall doors
AI or IA	Single	A	270 lbs.
60" x 80" 60" x 82" 60" x 96"	Multiple	B	30 lbs.
		C	210 lbs.
		D	500 lbs.
AI or IA	Single	A	130 lbs.
			B
72" x 82"	Multiple	C	175 lbs.
72" x 96"		D	500 lbs.

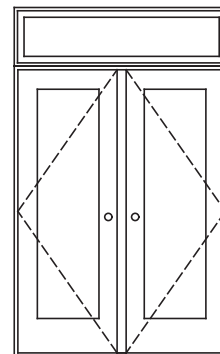

Single Unit  
Transom Condition

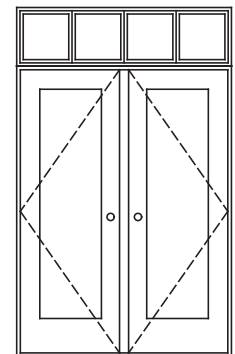

Multiple Unit  
Transom Condition  
(Two or more units)

Also check mullions for wind load limitations.



## Clad-Wood Combinations

### Door and Window Vertical Mullion

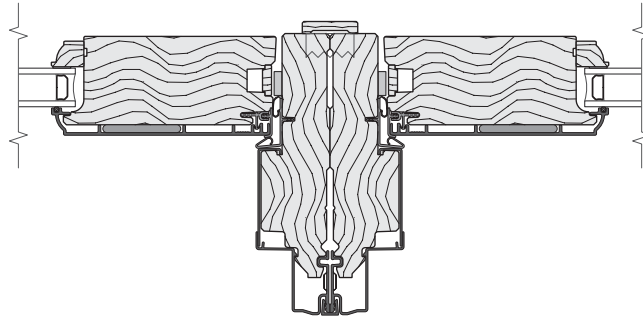

VERTICAL Combination (Joining)  
MULLION (Fixed Panels)

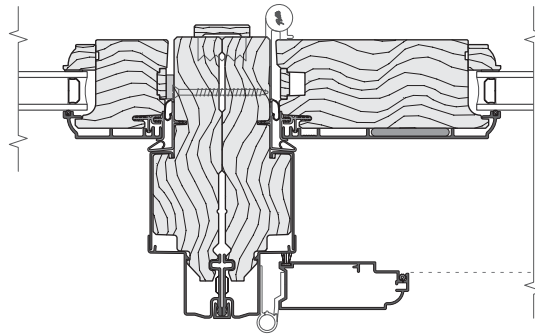

VERTICAL Combination (Joining)  
MULLION SIDELIGHT / HINGE JAMB  
(use 2" hinge screws)  
Similar at lock jamb and fixed jamb

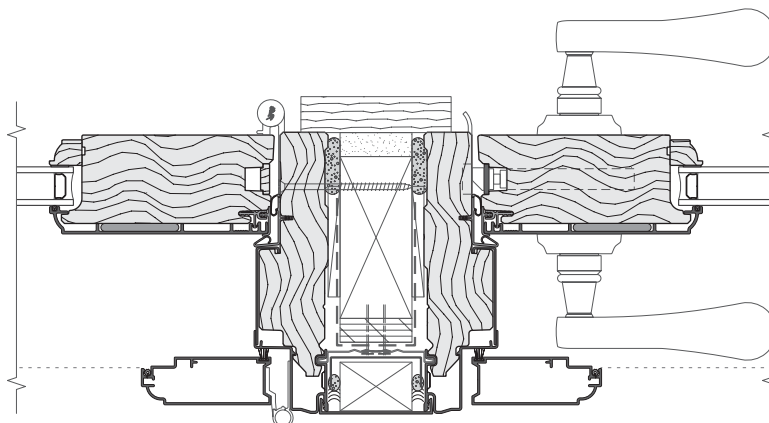

VERTICAL REINFORCING MULLION  
Operable Panels  
(lock Jamb/Hinge Jamb)  
Similar at lock jamb/lock jamb  
2" mullion cover #72A9 with this structural mullion.



# Clad-Wood Combinations

## Reinforcing Mullion Cross Sections

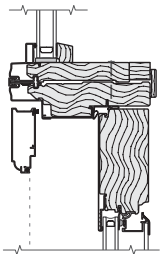
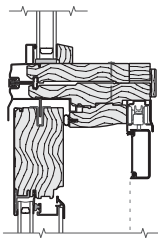
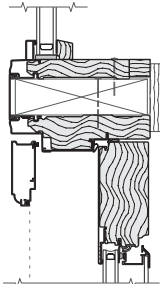
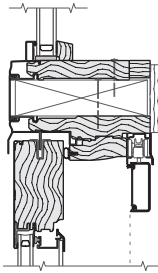
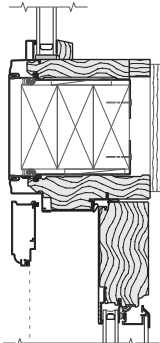
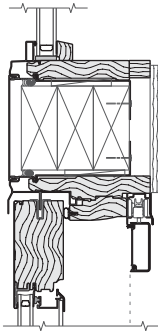
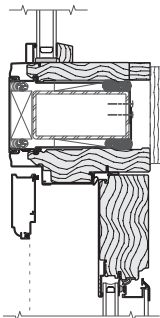
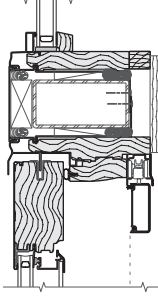
TRANSOM OVER IN-SWING FRENCH DOOR	TRANSOM OVER CLAD SLIDING DOOR	REINFORCEMENT
		A -  COMBINATION (Joining) MULLION (ANCHORS @ 12" O.C.)
		B -  2 x 6 WOOD BLOCKING
		C -  THREE 2 x 4 WOOD BLOCKING
		D -  2" x 4" x 3/16" STEEL TUBE



# Clad-Wood Combinations

## Door and Window Typical Combinations - Sample Calculations

The following sample calculations are based on steps on pages page W-CR-2 and page W-CR-3.

### 1. Determine the overall size of the combination

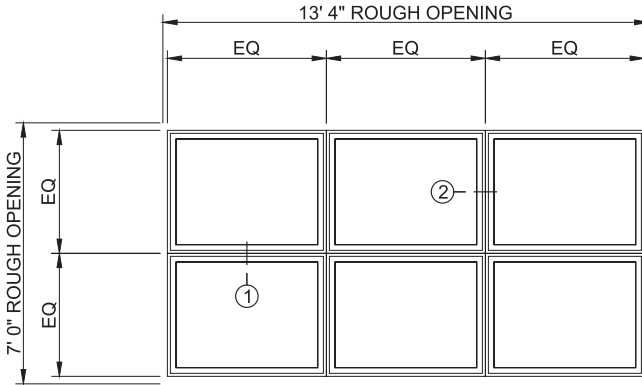

**Product:** Architect Series Fixed Clad Casement

**Size:** To be determined

**Glazing:** 5/8" Annealed Low-E IG with argon

### 2. Determine the required wind load (design pressure)

**Project description:**

Location: Pella, IA

Based on in ASCE 7-02, *Minimum Design Loads for Buildings and Other Structures*

Wind speed = 90 mph, Exposure C

Design Pressure: 28 psf

### 3. Determine individual window / door size and performance (nominal sizing)

Project design pressure: 28 psf

Required window / door performance class and grade rating: R30

Applicable Product – Architect Series, Clad, Fixed Casement Window

Individual window size and performance (see current online ADM for performance):

53" x 42" – Performance Class and Grade = C50

(Use the next largest unit to determine performance class and grade)

Result: Selected windows meet design pressure requirements.

FIXED UNITS			
Unit	Visible Glass Ft <sup>2</sup>	Frame Area Ft <sup>2</sup>	Performance Class & Grade <sub>1</sub>
4773	19.6	23.8	C50
5335	9.9	12.9	C50
5341	11.9	15.1	C50
5347	13.8	17.3	C50
5353	15.8	19.5	C50
5359	17.8	21.7	C50
5365	19.8	23.9	C50
5371	21.8	26.1	C50
5373	22.5	26.9	C50
5935	9.9	12.9	C50

### 4. Determine glazing performance

Glass Design Pressure Performance charts.

5342 – Performance = 43 psf

Result: Selected window glazing meets design pressure requirements.

### 5. Determine if the combination will be factory assembled or non-factory assembled

For this example, all combinations are non-factory assembled.

### 6. Determine mullion types and reinforcement requirements

Wind load (lateral loading) YES if yes, joint type: Joint ① = two-way joint

Joint ② = four-way joint

Dead Load (above doors and awning) Not Applicable.

Continued on next page





# Clad-Wood Combinations

## Door and Window Typical Combinations - Sample Calculations

7. Determine the appropriate mullion reinforcing:  
 (See pages 4 through 15 for notes and parameters)

Determine applicable combinations (See reinforcing mullion load charts).

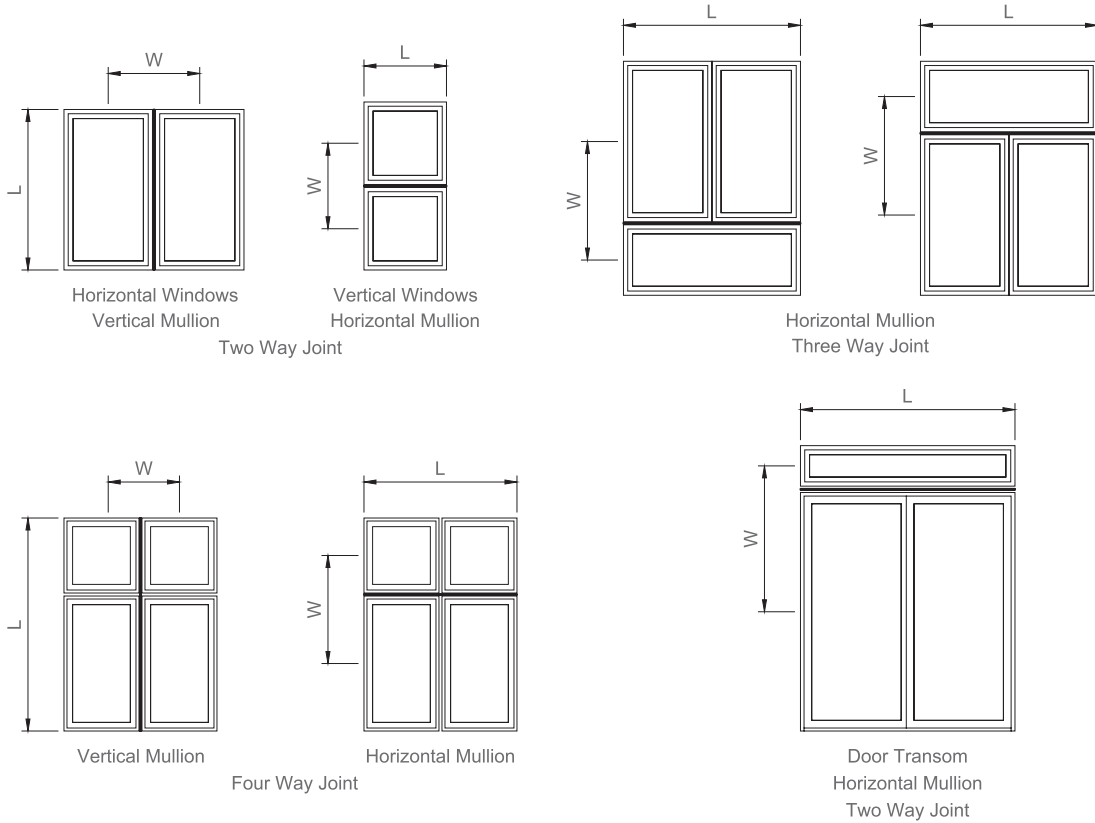

**Determine reinforcing mullion for joint ① = Two way joint**

- A. Determine L = Mullion length (In)
  - B. Determine W = Wind load width (In)  
 = 1/2 the distance from the mullion to the member above = 21"  
 + 1/2 the distance from the mullion to the member below = 21"
  - C. Determine minimum mullion required (Combination or complete mullion load chart is located in this section).
- Step 1** Enter the graph at the point of the mullion length (L).
- Step 2** Move to the loading width (W).
- Step 3** Move right to the column with the design pressure.

**Joint ①**

53"  
 42"  
  
 Use 53"  
 Use 47"  
 Use 30 psf

		Maximum Allowable Design Pressure (psf)			
		20	25	30	35
1	L (In)	53	47	AA	AA
2	W (In)	53	53	AA	AA
		53	59	AA	AA
		53	65	AA	AA
		53	71	AA	AA

See actual mullion load charts in this section for details.

Reinforcing mullion results:

Joint ① : AA - Standard combination (joining) mullion

Continued on next page



# Clad-Wood Combinations

## Door and Window Typical Combinations - Sample Calculations

### Determine reinforcing mullion for joint ②

- A. Determine L = Mullion length (In) (Rough Opening Height)
- B. Determine W = Wind load width (In)
  - = 1/2 the distance from the mullion to the member left = 26-1/2"
  - + 1/2 the distance from the mullion to the member right = 26-1/2"
- C. Determine minimum reinforcing mullion required (Complete reinforcing mullion load chart is located later in this section).

- Step 1** Enter the graph at the point of the mullion length (L).
- Step 2** Move to the loading width (W).
- Step 3** Move right to the column with the design pressure.

### Joint ②

84"

53"

Use 88"  
Use 53"  
Use 30 psf

		Maximum Allowable Design Pressure (psf)			
L (In)	W (In)	20	25	30	35
88	17	BB	BB	CC	CC
88	21	BB	CC	CC	CC
88	25	CC	CC	CC	CC
88	29	CC	CC	CC	EE
88	33	CC	CC	DD	EE
88	37	CC	CC	EE	EE
88	41	CC	EE	EE	FF
88	47	CC	EE	FF	FF
88	53	EE	EE	FF	FF
88	59	EE	FF	FF	GG
88	65	EE	FF	FF	GG
88	71	FF	FF	GG	GG

See actual mullion load charts in this section for details.

Reinforcing mullion results:

- FF = 1/2" Aluminum reinforcing mullion
- Use 1/2" x 4-9/16" Aluminum Reinforcing mullion

### 8. Determine if Subsill is required

Subsill systems that weep incidental moisture to the exterior are recommended for water management in openings where the potential for water infiltration is increased and may not be adequately managed by the building weather barrier, flashings and drainage system. Sample conditions include, but are not limited to: increased level of exposure due to multi-story construction, high weather exposure, recaulking would be difficult or unlikely, non-standard installation methods, or when there are multiple units joined within the opening.

Continued on next page



# Clad-Wood Combinations

## Door and Window Typical Combinations - Sample Calculations

### 9. Determine actual rough opening and window size data

Rough Opening Width:	Example:
Rough Opening	160"
Jamb Clearance (3/8" x 2)	- 3/4"
<u>Number of vertical mullions (2) x (mullion reinforcement width (1/2") + clearance when required)</u>	-1
Total Window width	158-1/4"
Total Window width ÷ number of windows (3)	52-3/4"

Rough Opening Height:	Example:
Rough Opening	84"
Deduct for subsill	1"
Deduct head clearance	- 1/2"
<u>Number of horizontal mullions x (reinforcing mullion width + clearance when required)</u>	0"
Total unit height	82-1/2"
Total unit height ÷ number of windows (2)	41-1/4"

### Final Layout and Detail

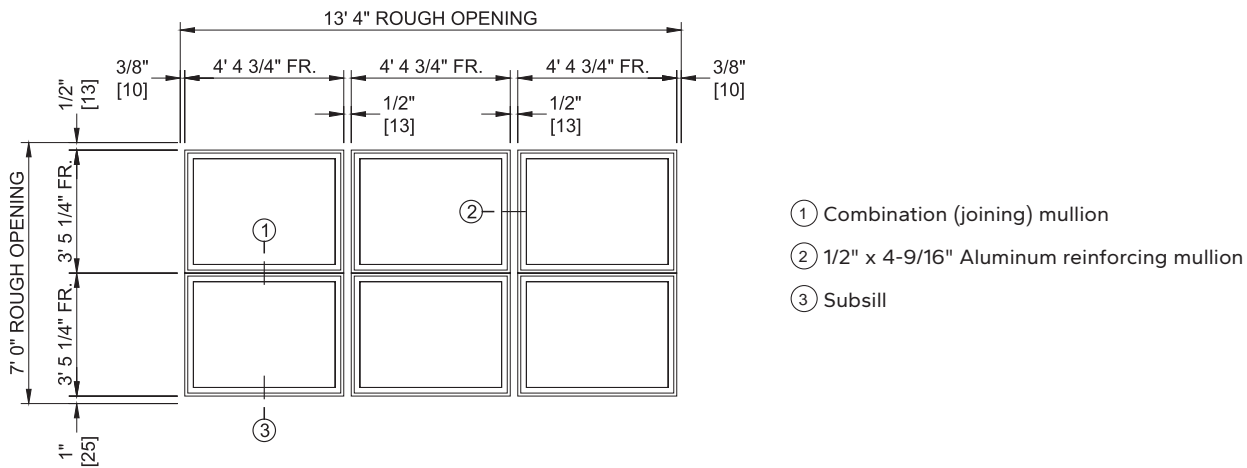

**Note:** To allow for standard unit sizes, rough opening or mullion dimension may need to change. If rough opening dimensions increases, recheck the glazing performance and reinforcing mullion.



### Introduction

Placing windows and doors in a combination creates joints or mullions that may need structural reinforcing. Spread mullions can also be utilized to achieve an aesthetic element. In order to ensure that a given combination will withstand the design pressure, use the reinforcing tables on the following pages. These tables are organized by joint type and assembly type (factory vs. non-factory assembled). Use the graphical representation of each joint type to determine which joint type(s) are contained within the combination. The reinforcing tables consider structural performance only. See the Size and Performance Data page within each product section for single unit performance class and grade ratings.

Also consider the tables for dead load when placing windows over awnings or doors.

**NOTE:** The mullions at the bottom of each page, the letters progress reflecting stronger mullions.

### Factory and Non-Factory Assembled Charts

- All reinforcing mullions must be properly secured at ends. Go to the Mullion End Anchor Capacity page for a formula to calculate end load of the reinforcing mullion, and for mullion anchor limitations. Wall framing around window opening must be adequate to withstand wind loads transferred from window combination and reinforcing mullions.
- Load charts are based on allowable deflection of  $L/175$  or maximum  $3/4"$ .
- If mullion length or load factor exceeds chart values (shaded areas), please contact your local Pella sales representative.
- Do not use these accessories or mullions for structural vertical loading. Reinforcing mullions are for wind loading only.
- For non-factory assembled mullions,  $1/4"$  minimum clearances are recommended on each side of the mullion structure.
- When using wood subsill with clad window, add  $3/4"$  to the opening height.
- For wood units, add  $1-1/8"$  to opening height for wood subsill.
- Wood units require special assembly.

### Impact-Resistant Glazing

- All Impact-Resistant Glazing combinations are available with clad exterior only.
- All factory-assembled combinations with Impact-Resistant Glazing will only meet Wind Zone 3 requirements and are not Hallmark Certified.
- Load charts are not valid for impact-resistant products used in Wind Zone 4 of wind borne debris protection required areas (Gulf and Atlantic coasts where wind speeds are 140 mph or higher, per ASCE 7). For these applications, see Miami-Dade Notice of Acceptance (NOA) 05-0105.01 or your local Pella sales representative.
- Review the Sample Calculation portion in this section and the Mullion Load Charts following to ensure the combination meets the structural load requirements. Add any structural reinforcing and make the appropriate adjustments to the rough opening. Review the loads on the Mullion End Anchor Capacity page placed on the rough opening at the ends of the reinforcing mullions. Design adjacent construction to receive those end loads.

### 1/2" Aluminum Reinforcing Mullion

- $1/2"$  aluminum reinforcing mullion is not suited for use at vertical mullions adjacent to doors.
- ProLine® doors and Entry Systems Doors are not suited for use with the  $1/2"$  aluminum reinforcing mullion.
- When the  $1/2"$  aluminum reinforcing mullion is used to mull a door and transom the combination must be checked for dead load. See the Weight Limitations of Transoms over Doors page in this section for more information.
- $1/2"$  aluminum reinforcing mullion cannot be used above Architect Series® Out-Swing Commercial doors or with doors that have automatic closures.



# Clad-Wood Combinations

## Mullion End Anchor Capacity

Use the following to determine end anchors for Pella reinforcing options.

### To Calculate End Load at Reinforcing Mullion:

$$\text{Load per end} = [(A + B) \times L \times P] / 2$$

A = 1/2 the distance in feet from the mullion for which the loading is being figured to the next structural member to the left.

B = 1/2 the distance in feet from the mullion for which the loading is being figured to the next structural member to the right.

P = Design wind load pressure required for the building project in pounds per square foot.

L = Mullion length in feet.

Attached To #2 Hemlock Fir with #10 Screws	Maximum Load Per Anchor In Pounds
Fin Anchor <sub>1</sub>	800 lbs.
1" to 1-1/2" Wood Mullion with Anchor	400 lbs.
2" to 4" Wood Mullion with Anchor	800 lbs.
Angled Anchor	830 lbs.
Subsill Anchor <sub>2</sub>	620 lbs.
High Performance Anchor	1260 lbs.

Attached to Concrete with 3/16" Masonry Screw <sub>3</sub>	Maximum Allowable Load per Anchor in Pounds
Fin Anchor <sub>1</sub>	800 lbs.
Angled Anchor	800 lbs.
Subsill Anchor <sub>2</sub>	800 lbs.

- (1) Requires only three concrete screws to perform at required levels.
- (2) Minimum 1" embedment into wood buck or concrete below subsill.
- (3) Minimum load capacity of 300 pounds required per screw. Verify performance with manufacturer.

### Example Assembly

#### Factory Assembled Wood Mullion End Anchors

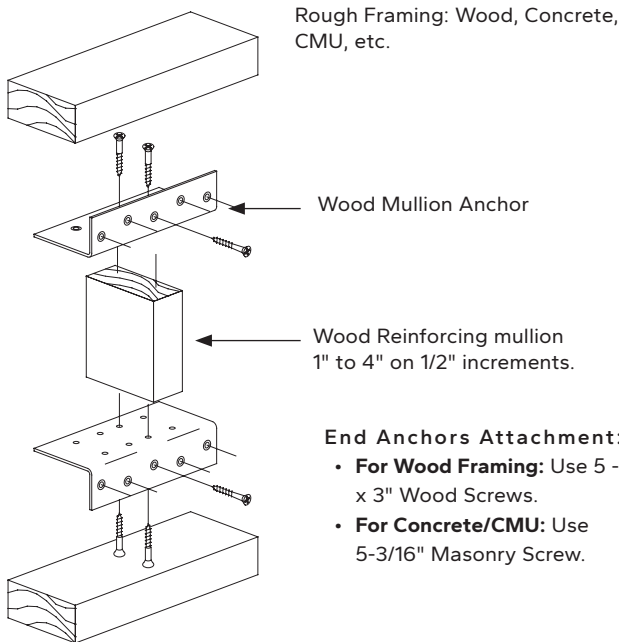

#### 1/2" Fin Mullion End Anchors

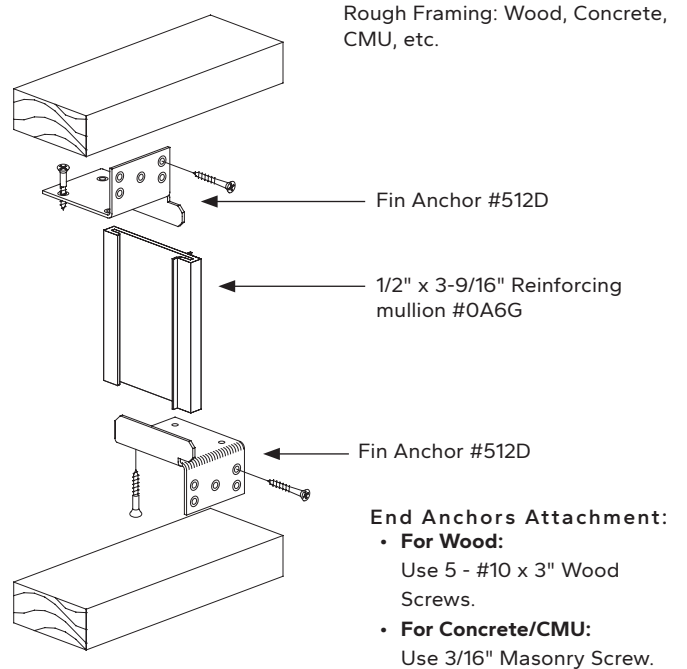

Screws have a 1" embedment into wood buck or concrete below subsill.

The 1/2" mullion assembly with end anchors 512D (fin mullion anchor), 000F (high performance fin mullion anchor) or 512A (wood fin mullion anchor) allow for installation of combinations that are assembled prior to being placed in the opening. Combinations assembled with this method should not exceed 144 square feet in total size. Always handle combinations in vertical orientation.



# Clad-Wood Combinations

## Factory Assembled Two-Way Joint - Window to Window Load Chart

L	W	20	25	30	35	40	45	50	55	60	65	70	75
(In)	(In)	Maximum Allowable Design Pressure (PSF)											
35	108	A	A	A	A	A	A	A	A	A	A	B	B
37	96	A	A	A	A	A	A	A	A	A	A	A	B
37	108	A	A	A	A	A	A	A	A	A	B	B	B
41	77	A	A	A	A	A	A	A	A	A	A	A	B
41	84	A	A	A	A	A	A	A	A	A	A	B	B
41	96	A	A	A	A	A	A	A	A	B	B	B	B
41	108	A	A	A	A	A	A	A	B	B	B	B	B
45	65	A	A	A	A	A	A	A	A	A	A	A	B
45	71	A	A	A	A	A	A	A	A	A	B	B	B
45	77	A	A	A	A	A	A	A	A	B	B	B	B
45	84	A	A	A	A	A	A	A	B	B	B	B	B
45	96	A	A	A	A	A	A	B	B	B	B	B	B
45	108	A	A	A	A	A	B	B	B	B	B	B	B
47	59	A	A	A	A	A	A	A	A	A	A	A	B
47	65	A	A	A	A	A	A	A	A	A	B	B	B
47	71	A	A	A	A	A	A	A	A	B	B	B	B
47	77	A	A	A	A	A	A	A	B	B	B	B	B
47	84	A	A	A	A	A	A	B	B	B	B	B	B
47	96	A	A	A	A	A	B	B	B	B	B	B	B
47	108	A	A	A	A	B	B	B	B	B	B	B	B
53	47	A	A	A	A	A	A	A	A	A	A	A	B
53	53	A	A	A	A	A	A	A	A	A	B	B	B
53	59	A	A	A	A	A	A	A	A	B	B	B	B
53	65	A	A	A	A	A	A	A	B	B	B	B	B
53	71	A	A	A	A	A	A	B	B	B	B	B	B
53	77	A	A	A	A	A	B	B	B	B	B	B	B
53	84	A	A	A	A	B	B	B	B	B	B	B	B
53	96	A	A	A	B	B	B	B	B	B	B	D	D
53	108	A	A	A	B	B	B	B	B	B	D	D	D
57	41	A	A	A	A	A	A	A	A	A	A	B	B
57	47	A	A	A	A	A	A	A	A	A	B	B	B
57	53	A	A	A	A	A	A	A	B	B	B	B	B
57	59	A	A	A	A	A	A	B	B	B	B	B	B
57	65	A	A	A	A	A	B	B	B	B	B	B	B
57	71	A	A	A	A	A	B	B	B	B	B	B	B
57	77	A	A	A	A	B	B	B	B	B	B	B	D
57	84	A	A	A	B	B	B	B	B	B	B	D	D
57	96	A	A	B	B	B	B	B	D	D	D	D	E
57	108	A	A	B	B	B	B	B	D	D	D	E	E
59	37	A	A	A	A	A	A	A	A	A	A	A	B
59	41	A	A	A	A	A	A	A	A	A	B	B	B
59	47	A	A	A	A	A	A	A	A	B	B	B	B
59	53	A	A	A	A	A	A	A	B	B	B	B	B
59	59	A	A	A	A	A	A	B	B	B	B	B	B
59	65	A	A	A	A	A	B	B	B	B	B	B	B
59	71	A	A	A	A	B	B	B	B	B	B	B	D
59	77	A	A	A	B	B	B	B	B	B	B	D	D
59	84	A	A	A	B	B	B	B	B	D	D	D	D
59	96	A	A	B	B	B	B	B	D	D	D	E	E
65	33	A	A	A	A	A	A	A	A	A	A	B	B
65	37	A	A	A	A	A	A	A	A	B	B	B	B
65	41	A	A	A	A	A	A	A	B	B	B	B	B
65	47	A	A	A	A	A	A	B	B	B	B	B	B
65	53	A	A	A	A	A	B	B	B	B	B	B	B
65	59	A	A	A	A	B	B	B	B	B	B	B	D
65	65	A	A	A	B	B	B	B	B	B	B	D	D
65	71	A	A	A	B	B	B	B	B	B	D	D	E
65	77	A	A	B	B	B	B	B	D	D	E	E	E
65	84	A	A	B	B	B	B	D	D	E	E	F	F
65	96	A	B	B	B	B	B	D	E	E	F	F	F

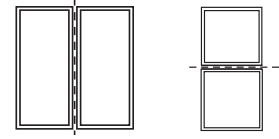

- All reinforcing mullions must be properly secured at ends. Wall framing around window opening must be adequate to withstand wind loads transferred from window composite and reinforcing mullions.
- Do not use these accessories or mullions for structural vertical loading. Reinforcing mullions are for wind loading only.
- If mullion length or load factor exceed chart values, please contact your local Pella sales representative.
- Design charts are not valid for locations where impact forces from airborne debris must be considered.
- To determine allowable mullion wind load for  $L/175 \leq .75"$  deflection go to page D-2 for instructions.

Chart 1 of 2





# Clad-Wood Combinations

## Factory Assembled Two-Way Joint - Window to Window Load Chart

L	W	20	25	30	35	40	45	50	55	60	65	70	75
(In)	(In)	Maximum Allowable Design Pressure (PSF)											
71	21	A	A	A	A	A	A	A	A	A	A	A	A
71	29	A	A	A	A	A	A	A	A	A	B	B	B
71	33	A	A	A	A	A	A	A	A	B	B	B	B
71	37	A	A	A	A	A	A	B	B	B	B	B	B
71	41	A	A	A	A	A	B	B	B	B	B	B	B
71	47	A	A	A	A	B	B	B	B	B	B	B	C
71	53	A	A	A	B	B	B	B	B	C	D	D	D
71	59	A	A	A	B	B	B	B	B	C	D	E	E
71	65	A	A	B	B	B	B	B	C	D	E	E	F
71	71	A	A	B	B	B	B	C	D	E	E	F	F
71	77	A	B	B	B	B	C	D	E	E	F	F	H
77	21	A	A	A	A	A	A	A	A	A	A	B	B
77	29	A	A	A	A	A	A	A	B	B	B	B	B
77	33	A	A	A	A	A	B	B	B	B	B	B	B
77	37	A	A	A	A	B	B	B	B	B	B	B	C
77	41	A	A	A	A	B	B	B	B	B	C	C	D
77	47	A	A	A	B	B	B	B	B	C	D	E	E
77	53	A	A	B	B	B	B	C	D	D	E	E	F
77	59	A	B	B	B	B	C	D	E	E	F	F	H
77	65	A	B	B	B	B	D	E	E	F	F	H	H
77	71	A	B	B	B	C	E	E	F	F	H	I	I
77	77	B	B	B	C	D	E	F	F	H	I	I	J
84	17	A	A	A	A	A	A	A	A	A	A	B	B
84	21	A	A	A	A	A	A	A	B	B	B	B	B
84	29	A	A	A	A	B	B	B	B	B	B	C	C
84	33	A	A	A	B	B	B	B	B	C	D	E	E
84	37	A	A	A	B	B	B	B	C	C	D	E	E
84	41	A	A	B	B	B	B	C	D	E	E	F	F
84	47	A	B	B	B	B	C	D	E	E	F	F	H
84	53	A	B	B	B	C	D	E	F	F	H	H	I
84	59	B	B	B	C	D	E	F	F	H	I	I	J
84	65	B	B	B	D	E	F	F	H	I	I	J	**
96	17	A	A	A	A	A	B	B	B	B	B	B	B
96	21	A	A	A	A	B	B	B	B	E	C	C	D
96	29	A	A	B	B	B	B	C	D	E	E	F	F
96	33	A	B	B	B	B	C	E	E	F	F	H	H
96	37	A	B	B	B	C	E	E	F	F	H	I	I
96	41	B	B	B	C	D	E	F	G	H	I	J	J
96	47	B	B	C	D	E	F	H	I	I	J	**	**
96	53	B	B	D	E	F	H	I	J	**	**	**	**
96	59	B	C	E	F	H	I	J	**	**	**	**	**
96	65	B	D	F	H	I	J	**	**	**	**	**	**
108	17	A	A	A	B	B	B	B	C	D	E	E	E
108	21	A	A	B	B	B	B	C	D	E	E	F	F
108	29	B	B	B	C	E	E	F	H	H	I	J	J
108	33	B	B	C	D	E	F	H	I	I	J	**	**
108	37	B	B	D	E	F	H	I	J	**	**	**	**
108	41	B	C	E	F	H	I	J	**	**	**	**	**
108	47	B	E	F	H	I	J	**	**	**	**	**	**
108	53	D	E	H	I	J	**	**	**	**	**	**	**
108	59	E	F	H	J	**	**	**	**	**	**	**	**
108	65	E	H	I	**	**	**	**	**	**	**	**	**

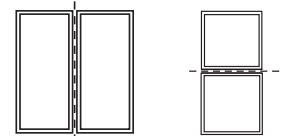

- All reinforcing mullions must be properly secured at ends. Wall framing around window opening must be adequate to withstand wind loads transferred from window composite and reinforcing mullions.
- Do not use these accessories or mullions for structural vertical loading. Reinforcing mullions are for wind loading only.
- If mullion length or load factor exceed chart values, please contact your local Pella sales representative.
- Design charts are not valid for locations where impact forces from airborne debris must be considered.
- To determine allowable mullion wind load for  $L/175 \leq .75"$  deflection go to page D-2 for instructions.

Chart 2 of 2

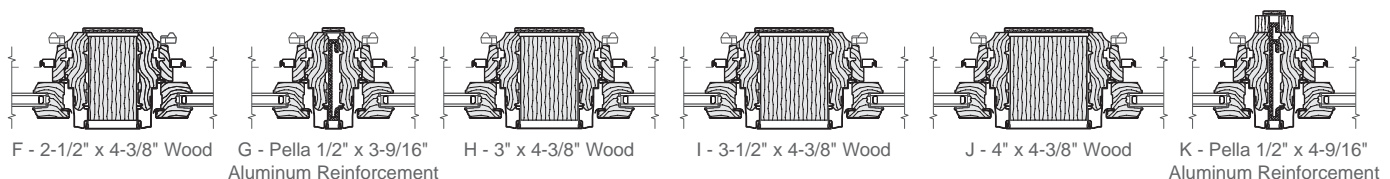



# Clad-Wood Combinations

## Factory Assembled Three-Way Joint - Window to Window Load Chart

L	W	20	25	30	35	40	45	50	55	60	65	70	75
(In)	(In)	Maximum Allowable Design Pressure (PSF)											
34	53	A	A	A	A	A	A	A	A	A	A	A	A
34	59	A	A	A	A	A	A	A	A	A	A	B	B
34	65	A	A	A	A	A	A	A	A	A	B	B	B
34	77	A	A	A	A	A	A	A	B	B	B	B	B
34	84	A	A	A	A	A	A	B	B	B	B	B	B
34	96	A	A	A	A	A	B	B	B	B	B	B	B
38	41	A	A	A	A	A	A	A	A	A	A	A	A
38	47	A	A	A	A	A	A	A	A	A	A	B	B
38	53	A	A	A	A	A	A	A	A	A	B	B	B
38	59	A	A	A	A	A	A	A	B	B	B	B	B
38	65	A	A	A	A	A	A	B	B	B	B	B	B
38	77	A	A	A	A	A	B	B	B	B	B	B	B
38	84	A	A	A	A	B	B	B	B	B	B	B	B
38	96	A	A	A	B	B	B	B	B	B	B	B	B
47	21	A	A	A	A	A	A	A	A	A	A	A	A
47	29	A	A	A	A	A	A	A	A	A	A	A	B
47	33	A	A	A	A	A	A	A	A	A	B	B	B
47	37	A	A	A	A	A	A	A	A	B	B	B	B
47	41	A	A	A	A	A	A	A	B	B	B	B	B
47	47	A	A	A	A	A	B	B	B	B	B	B	B
47	53	A	A	A	A	B	B	B	B	B	B	B	B
47	59	A	A	A	A	B	B	B	B	B	B	B	B
47	65	A	A	A	B	B	B	B	B	B	B	B	B
47	77	A	A	B	B	B	B	B	B	B	B	B	B
47	84	A	B	B	B	B	B	B	B	B	B	B	D
47	96	A	B	B	B	B	B	B	B	C	D	D	D
53	21	A	A	A	A	A	A	A	A	A	A	A	A
53	29	A	A	A	A	A	A	A	A	B	B	B	B
53	33	A	A	A	A	A	A	B	B	B	B	B	B
53	37	A	A	A	A	A	B	B	B	B	B	B	B
53	41	A	A	A	A	A	B	B	B	B	B	B	B
53	47	A	A	A	A	B	B	B	B	B	B	B	B
53	53	A	A	A	B	B	B	B	B	B	B	B	B
53	59	A	A	B	B	B	B	B	B	B	B	B	B
53	65	A	A	B	B	B	B	B	B	B	B	B	B
53	77	A	B	B	B	B	B	B	B	D	D	D	D
53	84	B	B	B	B	B	B	B	D	D	D	D	D
53	96	B	B	B	B	B	B	D	D	D	D	E	E
59	17	A	A	A	A	A	A	A	A	A	A	A	A
59	21	A	A	A	A	A	A	A	A	A	B	B	B
59	29	A	A	A	A	A	A	B	B	B	B	B	B
59	33	A	A	A	A	A	B	B	B	B	B	B	B
59	37	A	A	A	A	B	B	B	B	B	B	B	B
59	41	A	A	A	B	B	B	B	B	B	B	B	B
59	47	A	A	B	B	B	B	B	B	B	B	B	B
59	53	A	A	B	B	B	B	B	B	B	B	B	C
59	59	A	B	B	B	B	B	B	B	B	D	D	D
59	65	A	B	B	B	B	B	B	B	D	D	D	D
59	77	B	B	B	B	B	B	D	D	D	D	E	E
59	84	B	B	B	B	B	D	D	D	D	E	E	E
65	17	A	A	A	A	A	A	A	A	A	B	B	B
65	21	A	A	A	A	A	A	A	B	B	B	B	B
65	29	A	A	A	A	B	B	B	B	B	B	B	B
65	33	A	A	A	B	B	B	B	B	B	B	B	B
65	37	A	A	B	B	B	B	B	B	B	B	B	B
65	41	A	A	B	B	B	B	B	B	B	B	B	B
65	47	A	B	B	B	B	B	B	B	B	D	D	D
65	53	A	B	B	B	B	B	B	C	D	D	D	D
65	59	B	B	B	B	B	B	C	D	D	E	E	E
65	65	B	B	B	B	B	C	D	D	E	E	E	E
65	77	B	B	B	B	D	D	E	E	E	E	F	F
65	84	B	B	B	B	D	D	E	E	E	F	F	H

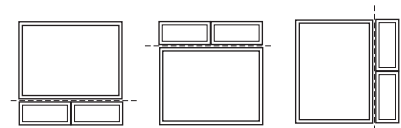

- All reinforcing mullions must be properly secured at ends. Wall framing around window opening must be adequate to withstand wind loads transferred from window composite and reinforcing mullions.
- Do not use these accessories or mullions for structural vertical loading. Reinforcing mullions are for wind loading only.
- If mullion length or load factor exceed chart values, please contact your local Pella sales representative.
- Design charts are not valid for locations where impact forces from airborne debris must be considered.
- To determine allowable mullion wind load for  $L/175 \leq .75"$  deflection go to page D-2 for instructions.

Chart 1 of 2

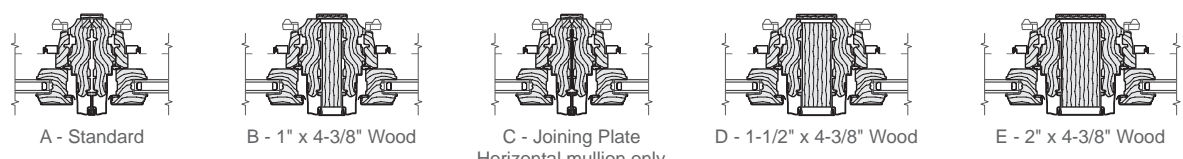





# Clad-Wood Combinations

## Factory Assembled Three-Way Joint - Window to Window Load Chart

L	W	20	25	30	35	40	45	50	55	60	65	70	75
(In)	(In)	Maximum Allowable Design Pressure (PSF)											
71	17	A	A	A	A	A	A	A	B	B	B	B	B
71	21	A	A	A	A	A	B	B	B	B	B	B	B
71	29	A	A	A	B	B	B	B	B	B	B	B	B
71	33	A	A	B	B	B	B	B	B	B	B	B	C
71	37	A	B	B	B	B	B	B	B	B	B	C	D
71	41	A	B	B	B	B	B	B	B	C	C	D	D
71	47	B	B	B	B	B	B	B	C	D	D	E	E
71	53	B	B	B	B	B	B	C	D	E	E	E	F
71	59	B	B	B	B	B	C	D	E	E	E	F	F
71	65	B	B	B	B	C	D	E	E	F	F	F	H
77	17	A	A	A	A	A	B	B	B	B	B	B	B
77	21	A	A	A	B	B	B	B	B	B	B	B	B
77	29	A	A	B	B	B	B	B	B	B	B	C	C
77	33	A	B	B	B	B	B	B	B	C	C	D	E
77	37	B	B	B	B	B	B	B	C	D	D	E	E
77	41	B	B	B	B	B	B	C	D	D	E	E	F
77	47	B	B	B	B	B	C	D	E	E	F	F	F
77	53	B	B	B	B	C	D	E	E	F	F	H	H
77	59	B	B	B	C	D	E	E	F	F	H	H	I
77	65	B	B	C	D	E	E	F	F	H	I	I	J
84	17	A	A	A	B	B	B	B	B	B	B	B	B
84	21	A	A	B	B	B	B	B	B	B	B	B	C
84	29	B	B	B	B	B	B	B	C	D	D	E	E
84	33	B	B	B	B	B	C	C	D	E	E	E	F
84	37	B	B	B	B	C	C	D	E	E	F	F	F
84	41	B	B	B	B	C	D	E	E	F	F	H	H
84	47	B	B	B	C	D	E	F	F	H	H	I	I
84	53	B	B	C	D	E	F	F	H	H	I	J	J
84	59	B	C	D	E	F	F	H	I	I	J	J	**
84	65	B	C	E	E	F	H	I	I	J	**	**	**
96	17	A	B	B	B	B	B	B	C	C	D	E	E
96	21	B	B	B	B	B	B	C	D	D	E	E	F
96	29	B	B	B	C	D	E	E	F	F	G	H	I
96	33	B	B	C	D	E	E	F	F	H	H	I	J
96	37	B	B	C	E	E	F	F	H	I	I	J	**
96	41	B	C	D	E	F	F	H	I	I	J	**	**
96	47	B	D	E	F	G	H	I	J	**	**	**	**
96	53	C	E	F	F	H	I	J	**	**	**	**	**
96	59	D	E	F	H	I	J	**	**	**	**	**	**
96	65	E	F	H	I	J	**	**	**	**	**	**	**
108	17	B	B	B	B	B	C	D	E	E	F	F	F
108	21	B	B	B	C	D	E	E	F	F	H	H	I
108	29	B	C	D	E	F	F	H	I	J	J	**	**
108	33	B	D	E	F	G	H	I	J	**	**	**	**
108	37	C	E	F	F	H	I	J	**	**	**	**	**
108	41	D	E	F	H	I	J	**	**	**	**	**	**
108	47	E	F	H	I	J	**	**	**	**	**	**	**
108	53	E	G	I	J	**	**	**	**	**	**	**	**
108	59	F	H	J	**	**	**	**	**	**	**	**	**
108	65	F	I	**	**	**	**	**	**	**	**	**	**

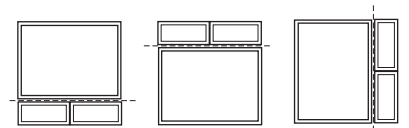

- All reinforcing mullions must be properly secured at ends. Wall framing around window opening must be adequate to withstand wind loads transferred from window composite and reinforcing mullions.
- Do not use these accessories or mullions for structural vertical loading. Reinforcing mullions are for wind loading only.
- If mullion length or load factor exceed chart values, please contact your local Pella sales representative.
- Design charts are not valid for locations where impact forces from airborne debris must be considered.
- To determine allowable mullion wind load for  $L/175 \leq .75"$  deflection go to page D-2 for instructions.

Chart 2 of 2

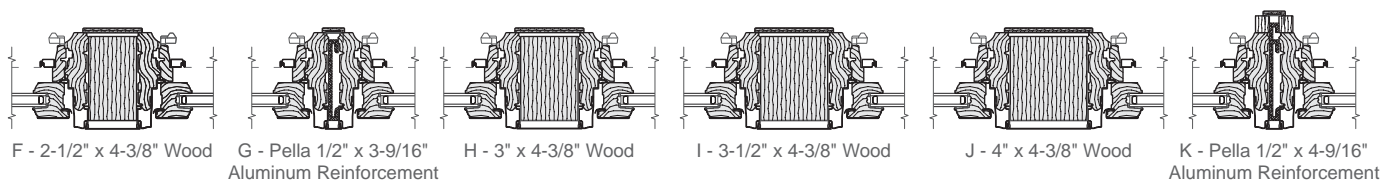



# Clad-Wood Combinations

## Factory Assembled Four-Way Joint - Window to Window Load Chart

L	W	20	25	30	35	40	45	50	55	60	65	70	75
(In)	(In)	Maximum Allowable Design Pressure (PSF)											
34	96	B	B	B	B	B	B	B	B	B	B	B	B
34	108	B	B	B	B	B	B	B	B	B	B	B	D
42	65	B	B	B	B	B	B	B	B	B	B	B	B
42	71	B	B	B	B	B	B	B	B	B	B	B	D
42	77	B	B	B	B	B	B	B	B	B	B	D	D
42	84	B	B	B	B	B	B	B	B	D	D	D	D
42	96	B	B	B	B	B	B	B	D	D	D	D	D
42	108	B	B	B	B	B	B	D	D	D	D	D	E
50	47	B	B	B	B	B	B	B	B	B	B	B	B
50	53	B	B	B	B	B	B	B	B	B	B	D	D
50	59	B	B	B	B	B	B	B	B	B	D	D	D
50	65	B	B	B	B	B	B	B	B	D	D	D	D
50	71	B	B	B	B	B	B	B	D	D	D	D	D
50	77	B	B	B	B	B	B	D	D	D	D	D	E
50	84	B	B	B	B	B	D	D	D	D	D	E	E
50	96	B	B	B	B	D	D	D	D	E	E	E	E
50	108	B	B	B	D	D	D	D	E	E	E	F	F
58	33	B	B	B	B	B	B	B	B	B	B	B	B
58	37	B	B	B	B	B	B	B	B	B	B	B	D
58	41	B	B	B	B	B	B	B	B	B	B	D	D
58	47	B	B	B	B	B	B	B	D	D	D	D	D
58	53	B	B	B	B	B	B	B	D	D	D	D	D
58	59	B	B	B	B	B	B	D	D	D	D	E	E
58	65	B	B	B	B	B	D	D	D	D	E	E	E
58	71	B	B	B	B	D	D	D	D	E	E	E	E
58	77	B	B	B	B	D	D	D	E	E	E	E	F
58	84	B	B	B	D	D	D	E	E	E	F	F	F
58	96	B	B	D	D	D	E	E	E	F	F	F	H
58	108	B	B	D	D	E	E	E	F	F	H	H	H
66	21	B	B	B	B	B	B	B	B	B	B	B	B
66	25	B	B	B	B	B	B	B	B	B	B	B	C
66	29	B	B	B	B	B	B	B	B	C	C	C	D
66	33	B	B	B	B	B	B	B	C	D	D	D	D
66	37	B	B	B	B	B	B	C	C	D	D	D	E
66	41	B	B	B	B	B	C	C	D	D	D	E	E
66	47	B	B	B	B	C	C	D	D	E	E	E	E
66	53	B	B	B	C	C	D	D	E	E	E	F	F
66	59	B	B	B	C	D	D	E	E	E	F	F	F
66	65	B	B	C	D	D	E	E	E	F	F	F	H
66	71	B	B	D	D	E	E	E	F	F	H	H	H
66	77	B	C	D	D	E	E	F	F	H	H	H	I
66	84	B	C	D	E	E	F	F	H	H	H	I	I
66	96	C	D	E	E	F	F	H	H	I	I	J	J
66	108	D	D	E	F	F	H	H	I	J	J	**	**
74	17	B	B	B	B	B	B	B	B	B	B	B	B
74	21	B	B	B	B	B	B	B	B	C	C	C	C
74	25	B	B	B	B	B	B	B	C	C	C	D	D
74	29	B	B	B	B	B	B	C	C	D	D	E	E
74	33	B	B	B	B	C	C	D	D	E	E	E	E
74	37	B	B	B	B	C	D	D	E	E	E	E	F
74	41	B	B	B	C	D	D	E	E	E	F	F	F
74	47	B	B	C	D	D	E	E	E	F	F	H	H
74	53	B	C	C	D	E	E	F	F	F	H	H	I
74	59	B	C	D	E	E	F	F	F	H	H	I	I
74	65	B	C	D	E	E	F	F	H	H	I	I	J
74	71	C	D	E	E	F	F	H	H	I	J	J	**
74	77	C	D	E	F	F	H	H	I	J	J	**	**
74	84	D	E	E	F	H	H	I	J	J	**	**	**
74	96	D	E	F	H	H	I	J	**	**	**	**	**
74	108	E	F	F	H	I	J	**	**	**	**	**	**

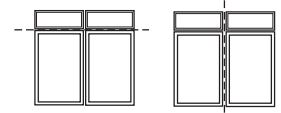

- All reinforcing mullions must be properly secured at ends. Wall framing around window opening must be adequate to withstand wind loads transferred from window composite and reinforcing mullions.
- Do not use these accessories or mullions for structural vertical loading. Reinforcing mullions are for wind loading only.
- If mullion length or load factor exceed chart values, please contact your local Pella sales representative.
- Design charts are not valid for locations where impact forces from airborne debris must be considered.
- To determine allowable mullion wind load for  $L/175 \leq .75"$  deflection go to page D-2 for instructions.

Chart 1 of 2

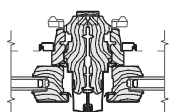

A - Standard

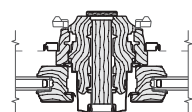

B - 1" x 4-3/8" Wood

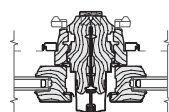

C - Joining Plate  
Horizontal mullion only

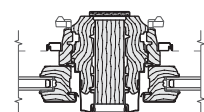

D - 1-1/2" x 4-3/8" Wood

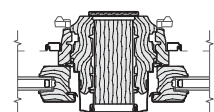

E - 2" x 4-3/8" Wood



# Clad-Wood Combinations

## Factory Assembled Four-Way Joint - Window to Window Load Chart

L	W	20	25	30	35	40	45	50	55	60	65	70	75
(In)	(In)	Maximum Allowable Design Pressure (PSF)											
88	17	B	B	B	B	B	B	C	C	D	D	E	E
88	21	B	B	B	B	C	C	D	D	E	E	F	F
88	25	B	B	B	C	D	D	E	E	F	F	H	H
88	29	B	B	C	D	D	E	E	F	F	F	H	H
88	33	B	C	D	D	E	E	F	F	H	H	I	I
88	37	B	C	D	E	E	F	F	H	H	I	I	J
88	41	C	D	E	E	F	F	H	H	I	I	J	J
88	47	C	E	E	F	F	H	I	I	J	J	**	**
88	53	D	E	F	F	H	I	I	J	**	**	**	**
88	59	E	E	F	H	I	I	J	**	**	**	**	**
88	65	E	F	G	H	I	J	**	**	**	**	**	**
88	71	E	F	H	I	J	**	**	**	**	**	**	**
97	17	B	B	B	C	C	D	D	E	E	F	F	F
97	21	B	B	C	D	D	E	E	F	F	H	H	H
97	25	B	C	D	E	E	E	F	F	H	H	I	I
97	29	C	C	E	E	F	F	G	H	I	I	J	J
97	33	C	D	E	E	F	H	H	I	I	J	J	**
97	37	D	E	E	F	H	H	I	J	J	**	**	**
97	41	D	E	F	F	H	I	J	J	**	**	**	**
97	47	E	F	F	H	I	J	**	**	**	**	**	**
97	53	E	F	H	I	J	**	**	**	**	**	**	**
97	59	F	H	I	J	**	**	**	**	**	**	**	**
97	65	F	H	I	J	**	**	**	**	**	**	**	**
108	17	B	C	C	D	E	E	F	F	F	H	H	I
108	21	B	C	D	E	E	F	F	H	H	I	I	J
108	25	C	D	E	F	F	H	H	I	J	J	**	**
108	29	D	E	F	F	H	I	I	J	**	**	**	**
108	33	E	E	F	H	I	J	J	**	**	**	**	**
108	37	E	F	H	I	J	**	**	**	**	**	**	**
108	41	E	F	H	I	J	**	**	**	**	**	**	**
108	47	F	H	I	J	**	**	**	**	**	**	**	**
108	53	G	I	J	**	**	**	**	**	**	**	**	**
108	59	H	J	**	**	**	**	**	**	**	**	**	**
108	65	I	J	**	**	**	**	**	**	**	**	**	**

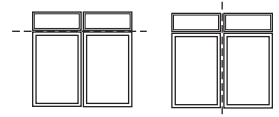

- All reinforcing mullions must be properly secured at ends. Wall framing around window opening must be adequate to withstand wind loads transferred from window composite and reinforcing mullions.
- Do not use these accessories or mullions for structural vertical loading. Reinforcing mullions are for wind loading only.
- If mullion length or load factor exceed chart values, please contact your local Pella sales representative.
- Design charts are not valid for locations where impact forces from airborne debris must be considered.
- To determine allowable mullion wind load for  $L/175 \leq .75"$  deflection go to page D-2 for instructions.

Chart 2 of 2

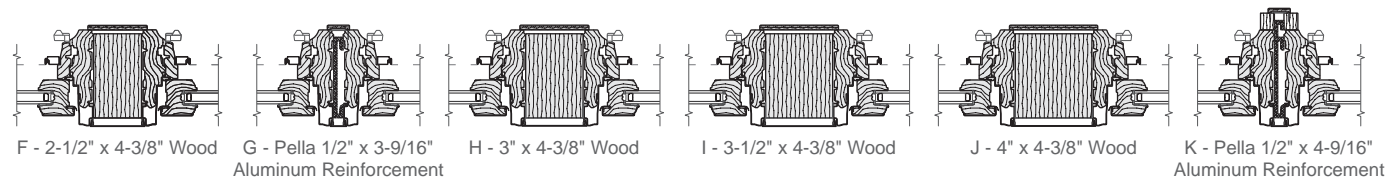



# Clad-Wood Combinations

## Factory Assembled Two-Way Joint - Door to Transom Load Chart

L	W	20	25	30	35	40	45	50	55	60	65	70	75
(In)	(In)	Maximum Allowable Design Pressure (PSF)											
81	36	A	A	A	A	B	B	B	B	B	B	D	D
81	42	A	A	A	B	B	B	B	B	D	D	E	E
81	50	A	A	B	B	B	B	D	D	E	E	F	F
81	60	A	B	B	B	B	D	E	E	F	F	H	I
81	67	A	B	B	B	D	E	E	F	H	H	I	J
81	72	B	B	B	D	D	E	F	H	H	I	J	J
81	75	B	B	B	D	E	E	F	H	I	I	J	**
81	96	B	B	D	E	F	H	I	J	**	**	**	**
81	108	B	D	E	F	H	I	J	**	**	**	**	**
81	117	B	E	F	H	I	J	**	**	**	**	**	**
81	141	D	F	H	J	**	**	**	**	**	**	**	**
81	144	D	F	H	J	**	**	**	**	**	**	**	**
81	189	F	I	**	**	**	**	**	**	**	**	**	**
82	36	A	A	A	A	B	B	B	B	B	D	D	D
82	42	A	A	A	B	B	B	B	B	D	D	E	E
82	50	A	A	B	B	B	B	D	D	E	E	F	F
82	60	A	B	B	B	D	D	E	F	F	H	H	I
82	67	A	B	B	D	D	E	F	F	H	I	I	J
82	72	B	B	B	D	E	E	F	H	I	I	J	**
82	75	B	B	B	D	E	F	F	H	I	J	**	**
82	96	B	D	E	F	H	I	J	**	**	**	**	**
82	108	B	D	E	G	I	J	**	**	**	**	**	**
82	117	D	E	F	H	I	**	**	**	**	**	**	**
82	141	E	F	H	J	**	**	**	**	**	**	**	**
82	144	E	F	I	J	**	**	**	**	**	**	**	**
82	189	G	I	**	**	**	**	**	**	**	**	**	**

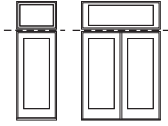

- All reinforcing mullions must be properly secured at ends. Wall framing around window opening must be adequate to withstand wind loads transferred from window composite and reinforcing mullions.
- Do not use these accessories or mullions for structural vertical loading. Reinforcing mullions are for wind loading only.
- If mullion length or load factor exceed chart values, please contact your local Pella sales representative.
- Design charts are not valid for locations where impact forces from airborne debris must be considered.
- To determine allowable mullion wind load for  $L/175 \leq .75$ " deflection go to page D-2 for instructions.

Chart 1 of 2

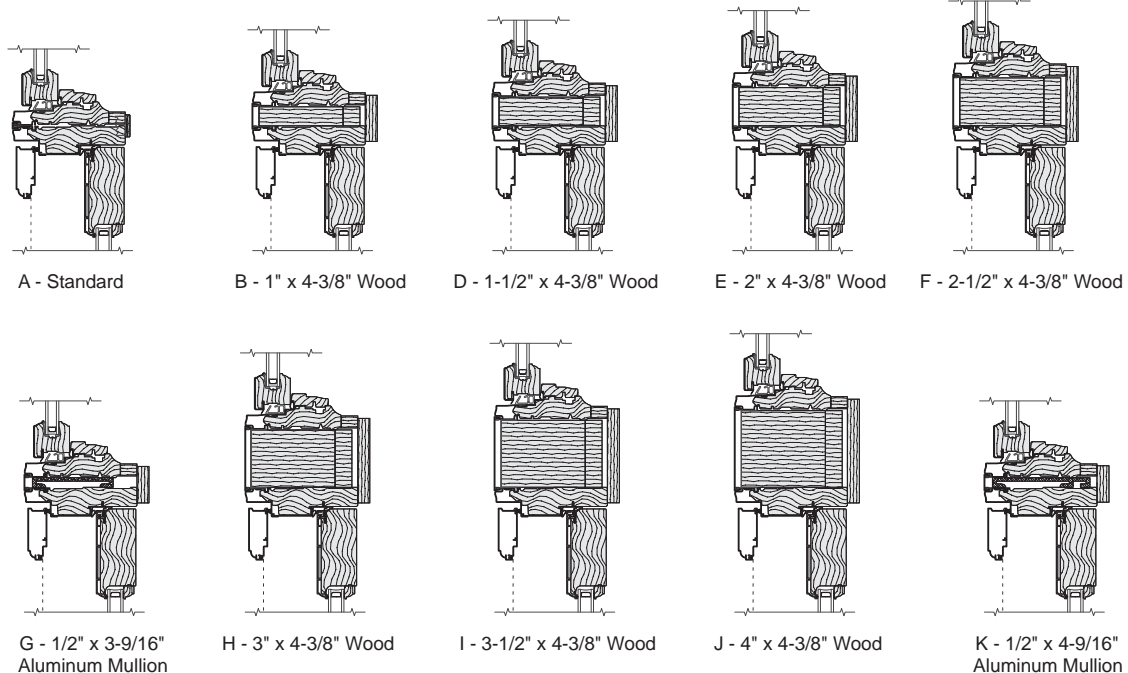



# Clad-Wood Combinations

## Factory Assembled Two-Way Joint - Door to Transom Load Chart

L	W	20	25	30	35	40	45	50	55	60	65	70	75
(In)	(In)	Maximum Allowable Design Pressure (PSF)											
86	36	A	A	A	B	B	B	B	B	D	D	E	E
86	42	A	A	B	B	B	B	D	D	E	E	F	F
86	50	A	B	B	B	B	D	E	E	F	F	H	I
86	60	B	B	B	D	D	E	F	H	H	I	J	J
86	67	B	B	B	D	E	F	H	H	I	J	**	**
86	72	B	B	D	E	F	F	H	I	J	**	**	**
86	75	B	B	D	E	F	H	I	J	J	**	**	**
86	96	B	D	F	H	I	J	**	**	**	**	**	**
86	108	D	E	F	I	J	**	**	**	**	**	**	**
86	117	D	F	H	I	**	**	**	**	**	**	**	**
86	141	E	H	J	**	**	**	**	**	**	**	**	**
86	144	F	H	J	**	**	**	**	**	**	**	**	**
86	189	I	**	**	**	**	**	**	**	**	**	**	**
96	36	A	B	B	B	B	D	E	E	F	F	H	I
96	42	A	B	B	D	D	E	F	F	H	I	I	J
96	50	B	B	D	D	E	F	H	I	J	**	**	**
96	60	B	D	E	F	H	I	J	**	**	**	**	**
96	67	B	D	E	F	I	J	**	**	**	**	**	**
96	72	B	E	F	H	I	J	**	**	**	**	**	**
96	75	D	E	F	H	J	**	**	**	**	**	**	**
96	96	E	H	I	**	**	**	**	**	**	**	**	**
96	108	F	I	J	**	**	**	**	**	**	**	**	**
96	117	F	I	**	**	**	**	**	**	**	**	**	**
117	48	D	F	H	J	**	**	**	**	**	**	**	**
117	50	E	F	I	J	**	**	**	**	**	**	**	**
117	54	E	H	I	**	**	**	**	**	**	**	**	**
117	55	E	H	J	**	**	**	**	**	**	**	**	**
117	57	F	H	J	**	**	**	**	**	**	**	**	**
117	61	F	I	**	**	**	**	**	**	**	**	**	**

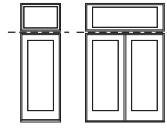

- All reinforcing mullions must be properly secured at ends. Wall framing around window opening must be adequate to withstand wind loads transferred from window composite and reinforcing mullions.
- Do not use these accessories or mullions for structural vertical loading. Reinforcing mullions are for wind loading only.
- If mullion length or load factor exceed chart values, please contact your local Pella sales representative.
- Design charts are not valid for locations where impact forces from airborne debris must be considered.
- To determine allowable mullion wind load for  $L/175 \leq .75$ " deflection go to page D-2 for instructions.

Chart 2 of 2

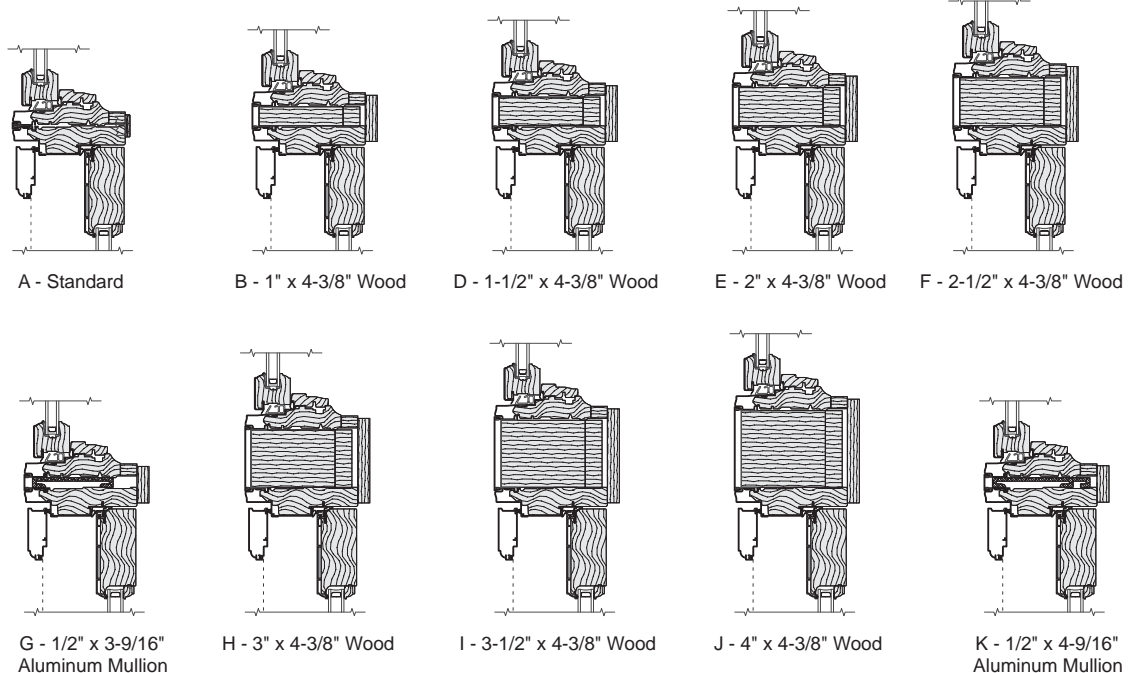



# Clad-Wood Combinations

## Factory Assembled Three-Way Joint - Door to Windows Load Chart

L	W	20	25	30	35	40	45	50	55	60	65	70	75
(In)	(In)	Maximum Allowable Design Pressure (PSF)											
81	48	B	B	B	B	D	D	E	E	F	F	H	H
81	50	B	B	B	B	D	D	E	E	F	F	H	H
81	54	B	B	B	D	D	E	E	F	F	H	H	I
81	55	B	B	B	D	D	E	E	F	G	H	I	I
81	57	B	B	B	D	D	E	F	F	H	H	I	I
81	61	B	B	D	D	E	E	F	H	H	I	I	J
82	48	B	B	B	B	D	D	E	E	F	F	H	H
82	50	B	B	B	D	D	E	E	F	F	H	H	I
82	54	B	B	B	D	D	E	F	F	H	H	I	I
82	55	B	B	B	D	D	E	F	F	H	H	I	I
82	57	B	B	B	D	E	E	F	F	H	I	I	J
82	61	B	B	D	D	E	F	F	H	I	I	J	J
86	48	B	B	B	D	E	E	F	F	H	H	I	J
86	50	B	B	D	D	E	E	F	G	H	I	I	J
86	54	B	B	D	D	E	F	F	H	I	I	J	**
86	55	B	B	D	E	E	F	G	H	I	I	J	**
86	57	B	B	D	E	E	F	H	H	I	J	J	**
86	61	B	D	D	E	F	F	H	I	J	J	**	**
96	48	B	D	E	F	F	H	I	J	**	**	**	**
96	50	B	D	E	F	H	H	I	J	**	**	**	**
96	54	D	D	E	F	H	I	J	**	**	**	**	**
96	55	D	D	E	F	H	I	J	**	**	**	**	**
96	57	D	E	F	H	I	I	J	**	**	**	**	**
96	61	D	E	F	H	I	J	**	**	**	**	**	**
117	48	F	H	J	**	**	**	**	**	**	**	**	**
117	50	F	H	J	**	**	**	**	**	**	**	**	**
117	54	F	I	**	**	**	**	**	**	**	**	**	**
117	55	G	I	**	**	**	**	**	**	**	**	**	**
117	57	H	J	**	**	**	**	**	**	**	**	**	**
117	61	H	J	**	**	**	**	**	**	**	**	**	**

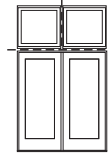

- All reinforcing mullions must be properly secured at ends. Wall framing around window opening must be adequate to withstand wind loads transferred from window composite and reinforcing mullions.
- Do not use these accessories or mullions for structural vertical loading. Reinforcing mullions are for wind loading only.
- If mullion length or load factor exceed chart values, please contact your local Pella sales representative.
- Design charts are not valid for locations where impact forces from airborne debris must be considered.
- To determine allowable mullion wind load for  $L/175 \leq .75"$  deflection go to page D-2 for instructions.

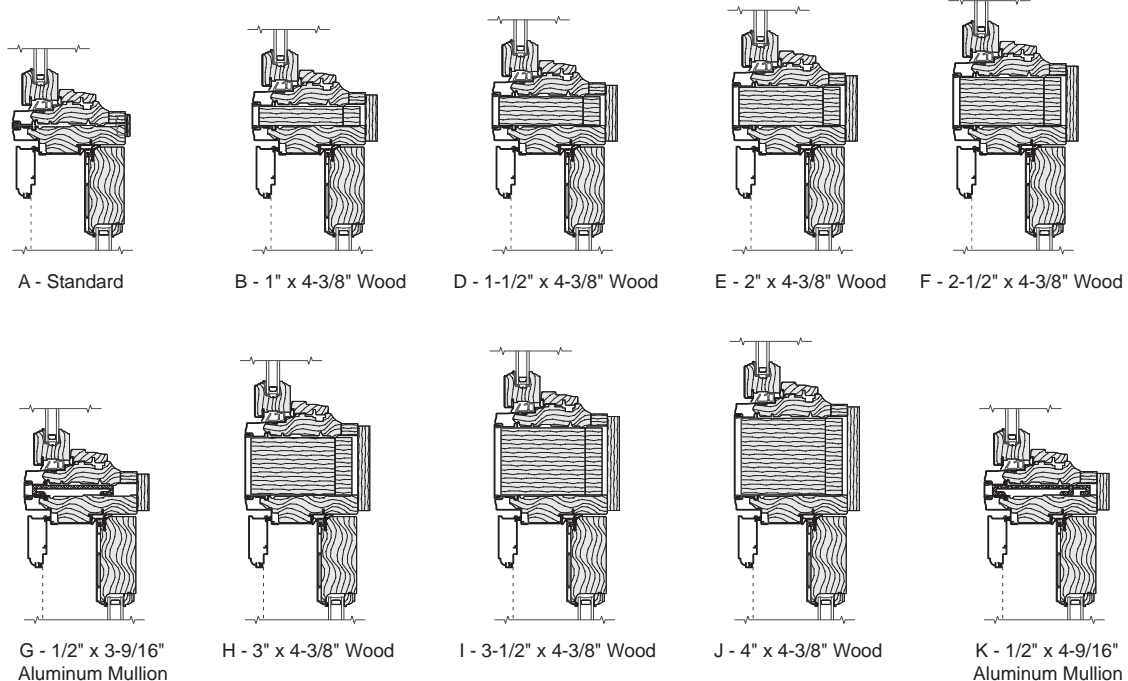



# Clad-Wood Combinations

## Non-Factory Assembled Two-Way Joint - Window to Window Load Chart

L	W	20	25	30	35	40	45	50	55	60	65	70	75
(In)	(In)	Maximum Allowable Design Pressure (PSF)											
35	108	AA	AA	AA	AA	AA	AA	AA	AA	AA	AA	BB	BB
37	96	AA	AA	AA	AA	AA	AA	AA	AA	AA	AA	AA	BB
37	108	AA	AA	AA	AA	AA	AA	AA	AA	AA	AA	BB	BB
41	77	AA	AA	AA	AA	AA	AA	AA	AA	AA	AA	AA	BB
41	84	AA	AA	AA	AA	AA	AA	AA	AA	AA	AA	BB	BB
41	96	AA	AA	AA	AA	AA	AA	AA	AA	BB	BB	BB	BB
41	108	AA	AA	AA	AA	AA	AA	AA	AA	BB	BB	BB	BB
45	65	AA	AA	AA	AA	AA	AA	AA	AA	AA	AA	AA	BB
45	71	AA	AA	AA	AA	AA	AA	AA	AA	AA	BB	BB	BB
45	77	AA	AA	AA	AA	AA	AA	AA	AA	BB	BB	BB	BB
45	84	AA	AA	AA	AA	AA	AA	AA	AA	BB	BB	BB	BB
45	96	AA	AA	AA	AA	AA	AA	BB	BB	BB	BB	BB	DD
45	108	AA	AA	AA	AA	AA	BB	BB	BB	BB	DD	DD	DD
47	59	AA	AA	AA	AA	AA	AA	AA	AA	AA	AA	AA	BB
47	65	AA	AA	AA	AA	AA	AA	AA	AA	AA	BB	BB	BB
47	71	AA	AA	AA	AA	AA	AA	AA	AA	BB	BB	BB	BB
47	77	AA	AA	AA	AA	AA	AA	AA	BB	BB	BB	BB	BB
47	84	AA	AA	AA	AA	AA	AA	BB	BB	BB	BB	BB	DD
47	96	AA	AA	AA	AA	AA	BB	BB	BB	BB	DD	DD	DD
47	108	AA	AA	AA	AA	BB	BB	BB	BB	DD	DD	DD	DD
53	47	AA	AA	AA	AA	AA	AA	AA	AA	AA	AA	AA	BB
53	53	AA	AA	AA	AA	AA	AA	AA	AA	AA	BB	BB	BB
53	59	AA	AA	AA	AA	AA	AA	AA	AA	BB	BB	BB	BB
53	65	AA	AA	AA	AA	AA	AA	AA	BB	BB	BB	BB	DD
53	71	AA	AA	AA	AA	AA	AA	BB	BB	BB	BB	DD	DD
53	77	AA	AA	AA	AA	AA	BB	BB	BB	BB	DD	DD	DD
53	84	AA	AA	AA	AA	BB	BB	BB	BB	DD	DD	DD	DD
53	96	AA	AA	AA	BB	BB	BB	BB	DD	DD	DD	EE	FF
53	108	AA	AA	AA	BB	BB	DD	DD	DD	DD	EE	FF	FF
57	41	AA	AA	AA	AA	AA	AA	AA	AA	AA	AA	BB	BB
57	47	AA	AA	AA	AA	AA	AA	AA	AA	AA	BB	BB	BB
57	53	AA	AA	AA	AA	AA	AA	AA	BB	BB	BB	BB	BB
57	59	AA	AA	AA	AA	AA	AA	BB	BB	BB	BB	BB	DD
57	65	AA	AA	AA	AA	AA	BB	BB	BB	BB	DD	DD	DD
57	71	AA	AA	AA	AA	AA	BB	BB	BB	DD	DD	DD	DD
57	77	AA	AA	AA	AA	BB	BB	BB	DD	DD	DD	DD	DD
57	84	AA	AA	AA	BB	BB	BB	DD	DD	DD	DD	EE	FF
57	96	AA	AA	BB	BB	BB	DD	DD	DD	DD	FF	FF	FF
57	108	AA	AA	BB	BB	DD	DD	DD	DD	EE	FF	FF	FF
59	37	AA	AA	AA	AA	AA	AA	AA	AA	AA	AA	AA	BB
59	41	AA	AA	AA	AA	AA	AA	AA	AA	AA	AA	BB	BB
59	47	AA	AA	AA	AA	AA	AA	AA	AA	BB	BB	BB	BB
59	53	AA	AA	AA	AA	AA	AA	AA	BB	BB	BB	BB	DD
59	59	AA	AA	AA	AA	AA	AA	BB	BB	BB	BB	DD	DD
59	65	AA	AA	AA	AA	AA	BB	BB	BB	BB	DD	DD	DD
59	71	AA	AA	AA	AA	BB	BB	BB	BB	DD	DD	DD	DD
59	77	AA	AA	AA	BB	BB	BB	BB	DD	DD	DD	DD	FF
59	84	AA	AA	AA	BB	BB	BB	DD	DD	DD	EE	FF	FF
59	96	AA	AA	BB	BB	BB	DD	DD	DD	DD	EE	FF	FF
65	33	AA	AA	AA	AA	AA	AA	AA	AA	AA	AA	BB	BB
65	37	AA	AA	AA	AA	AA	AA	AA	AA	BB	BB	BB	BB
65	41	AA	AA	AA	AA	AA	AA	AA	BB	BB	BB	BB	BB
65	47	AA	AA	AA	AA	AA	AA	BB	BB	BB	BB	DD	DD
65	53	AA	AA	AA	AA	AA	BB	BB	BB	BB	DD	DD	DD
65	59	AA	AA	AA	AA	BB	BB	BB	DD	DD	DD	DD	DD
65	65	AA	AA	AA	BB	BB	BB	DD	DD	DD	DD	EE	FF
65	71	AA	AA	AA	BB	BB	BB	DD	DD	DD	DD	EE	FF
65	77	AA	AA	BB	BB	BB	DD	DD	DD	EE	FF	FF	FF
65	84	AA	AA	BB	BB	DD	DD	DD	DD	EE	FF	FF	FF
65	96	AA	BB	BB	DD	DD	DD	DD	DD	FF	FF	GG	HH

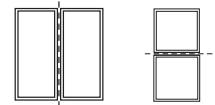

- All reinforcing mullions must be properly secured at ends. Wall framing around window opening must be adequate to withstand wind loads transferred from window composite and reinforcing mullions.
- Do not use these accessories or mullions for structural vertical loading. Reinforcing mullions are for wind loading only.
- If mullion length or load factor exceed chart values, please contact your local Pella sales representative.
- Design charts are not valid for locations where impact forces from airborne debris must be considered.
- To determine allowable mullion wind load for  $L/175 \leq .75"$  deflection go to page D-2 for instructions.

Chart 1 of 2

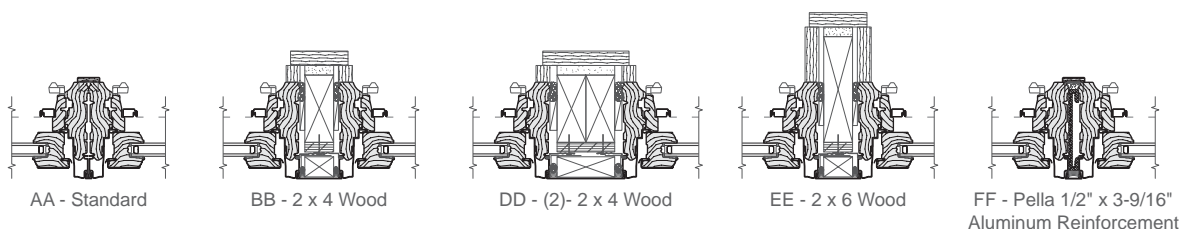



# Clad-Wood Combinations

## Non-Factory Assembled Two-Way Joint - Window to Window Load Chart

L	W	20	25	30	35	40	45	50	55	60	65	70	75
(In)	(In)	Maximum Allowable Design Pressure (PSF)											
71	21	AA	AA	AA	AA	AA	AA	AA	AA	AA	AA	AA	AA
71	29	AA	AA	AA	AA	AA	AA	AA	AA	AA	BB	BB	BB
71	33	AA	AA	AA	AA	AA	AA	AA	AA	BB	BB	BB	BB
71	37	AA	AA	AA	AA	AA	AA	BB	BB	BB	BB	BB	DD
71	41	AA	AA	AA	AA	AA	BB	BB	BB	BB	BB	DD	DD
71	47	AA	AA	AA	AA	BB	BB	BB	BB	DD	DD	DD	DD
71	53	AA	AA	AA	BB	BB	BB	BB	DD	DD	DD	DD	EE
71	59	AA	AA	AA	BB	BB	BB	DD	DD	DD	EE	FF	FF
71	65	AA	AA	BB	BB	BB	DD	DD	DD	EE	FF	FF	FF
71	71	AA	AA	BB	BB	DD	DD	DD	EE	FF	FF	FF	FF
71	77	AA	BB	BB	BB	DD	DD	EE	FF	FF	FF	GG	GG
77	21	AA	AA	AA	AA	AA	AA	AA	AA	AA	AA	BB	BB
77	29	AA	AA	AA	AA	AA	AA	AA	BB	BB	BB	BB	BB
77	33	AA	AA	AA	AA	AA	BB	BB	BB	BB	BB	DD	DD
77	37	AA	AA	AA	AA	BB	BB	BB	BB	DD	DD	DD	DD
77	41	AA	AA	AA	AA	BB	BB	BB	DD	DD	DD	DD	EE
77	47	AA	AA	AA	BB	BB	BB	DD	DD	DD	EE	EE	FF
77	53	AA	AA	BB	BB	BB	DD	DD	DD	EE	FF	FF	FF
77	59	AA	BB	BB	BB	DD	DD	EE	EE	FF	FF	FF	GG
77	65	AA	BB	BB	DD	DD	DD	EE	FF	FF	FF	GG	GG
77	71	AA	BB	BB	DD	DD	EE	FF	FF	FF	GG	GG	HH
77	77	BB	BB	DD	DD	EE	FF	FF	FF	GG	GG	HH	II
84	17	AA	AA	AA	AA	AA	AA	AA	AA	AA	AA	BB	BB
84	21	AA	AA	AA	AA	AA	AA	AA	BB	BB	BB	BB	BB
84	29	AA	AA	AA	AA	BB	BB	BB	BB	DD	DD	DD	DD
84	33	AA	AA	AA	BB	BB	BB	BB	DD	DD	DD	EE	EE
84	37	AA	AA	AA	BB	BB	BB	DD	DD	DD	EE	EE	EE
84	41	AA	AA	BB	BB	BB	DD	DD	DD	EE	EE	FF	FF
84	47	AA	BB	BB	BB	DD	DD	EE	EE	EE	FF	FF	GG
84	53	AA	BB	BB	DD	DD	EE	EE	FF	FF	GG	GG	GG
84	59	BB	BB	DD	DD	EE	EE	FF	FF	GG	GG	GG	HH
84	65	BB	BB	DD	EE	EE	FF	FF	GG	GG	GG	HH	II
96	17	AA	AA	AA	AA	AA	BB	BB	BB	BB	BB	DD	DD
96	21	AA	AA	AA	AA	BB	BB	BB	DD	DD	DD	DD	EE
96	29	AA	AA	BB	BB	DD	DD	DD	EE	EE	EE	EE	EE
96	33	AA	BB	BB	DD	DD	DD	EE	EE	EE	EE	GG	GG
96	37	AA	BB	BB	DD	DD	EE	EE	EE	FF	GG	GG	GG
96	41	BB	BB	DD	DD	EE	EE	EE	FF	GG	GG	GG	GG
96	47	BB	DD	DD	EE	EE	EE	GG	GG	GG	GG	HH	II
96	53	BB	DD	EE	EE	EE	GG	GG	GG	HH	II	II	II
96	59	DD	DD	EE	EE	GG	GG	GG	HH	II	II	II	II
96	65	DD	EE	EE	GG	GG	GG	HH	II	II	II	II	KK
108	17	AA	AA	AA	BB	BB	BB	DD	DD	DD	EE	EE	EE
108	21	AA	AA	BB	BB	DD	DD	DD	EE	EE	EE	EE	FF
108	29	BB	BB	DD	DD	EE	EE	EE	GG	GG	GG	GG	GG
108	33	BB	DD	DD	EE	EE	EE	GG	GG	GG	GG	HH	II
108	37	BB	DD	EE	EE	EE	GG	GG	GG	HH	II	II	II
108	41	DD	DD	EE	EE	GG	GG	GG	HH	II	II	II	II
108	47	DD	EE	EE	GG	GG	GG	HH	II	II	II	JJ	JJ
108	53	DD	EE	GG	GG	GG	HH	II	II	II	JJ	KK	KK
108	59	EE	EE	GG	GG	HH	II	II	JJ	JJ	KK	KK	KK
108	65	EE	GG	GG	HH	II	II	JJ	JJ	KK	KK	KK	KK

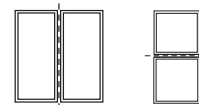

- All reinforcing mullions must be properly secured at ends. Wall framing around window opening must be adequate to withstand wind loads transferred from window composite and reinforcing mullions.
- Do not use these accessories or mullions for structural vertical loading. Reinforcing mullions are for wind loading only.
- If mullion length or load factor exceed chart values, please contact your local Pella sales representative.
- Design charts are not valid for locations where impact forces from airborne debris must be considered.
- To determine allowable mullion wind load for  $L/175 \leq .75"$  deflection go to page D-2 for instructions.

Chart 2 of 2

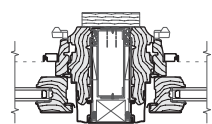

GG - 18 ga. 1-3/8" x 3-5/8"  
Nested Steel Stud

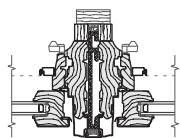

HH - Pella 1/2" x 4-9/16"  
Aluminum Reinforcement

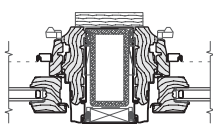

II - 2" x 4" x 1/4"  
Aluminum Tube

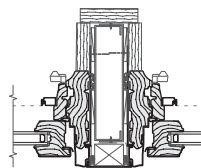

JJ - 20 ga. 1-3/8" x 6"  
Nested Steel Stud

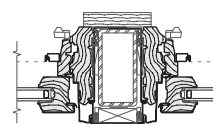

KK - 2" x 4" x 3/16"  
Steel Tube





# Clad-Wood Combinations

## Non-Factory Assembled Three-Way Joint - Window to Window Load Chart

L	W	20	25	30	35	40	45	50	55	60	65	70	75
(In)	(In)	Maximum Allowable Design Pressure (PSF)											
34	53	AA	AA	AA	AA	AA	AA	AA	AA	AA	AA	AA	AA
34	59	AA	AA	AA	AA	AA	AA	AA	AA	AA	AA	BB	BB
34	65	AA	AA	AA	AA	AA	AA	AA	AA	AA	BB	BB	BB
34	77	AA	AA	AA	AA	AA	AA	AA	BB	BB	BB	BB	BB
34	84	AA	AA	AA	AA	AA	AA	BB	BB	BB	BB	BB	BB
34	96	AA	AA	AA	AA	AA	BB	BB	BB	BB	BB	BB	BB
38	41	AA	AA	AA	AA	AA	AA	AA	AA	AA	AA	AA	AA
38	47	AA	AA	AA	AA	AA	AA	AA	AA	AA	AA	BB	BB
38	53	AA	AA	AA	AA	AA	AA	AA	AA	AA	BB	BB	BB
38	59	AA	AA	AA	AA	AA	AA	AA	BB	BB	BB	BB	BB
38	65	AA	AA	AA	AA	AA	AA	BB	BB	BB	BB	BB	BB
38	77	AA	AA	AA	AA	AA	BB	BB	BB	BB	BB	BB	BB
38	84	AA	AA	AA	AA	BB	BB	BB	BB	BB	BB	BB	CC
38	96	AA	AA	AA	BB	BB	BB	BB	BB	BB	CC	DD	DD
47	21	AA	AA	AA	AA	AA	AA	AA	AA	AA	AA	AA	AA
47	29	AA	AA	AA	AA	AA	AA	AA	AA	AA	AA	AA	BB
47	33	AA	AA	AA	AA	AA	AA	AA	AA	AA	BB	BB	BB
47	37	AA	AA	AA	AA	AA	AA	AA	AA	BB	BB	BB	BB
47	41	AA	AA	AA	AA	AA	AA	AA	BB	BB	BB	BB	BB
47	47	AA	AA	AA	AA	AA	BB	BB	BB	BB	BB	BB	BB
47	53	AA	AA	AA	AA	BB	BB	BB	BB	BB	BB	BB	BB
47	59	AA	AA	AA	AA	BB	BB	BB	BB	BB	BB	CC	DD
47	65	AA	AA	AA	BB	BB	BB	BB	BB	BB	DD	DD	DD
47	77	AA	AA	BB	BB	BB	BB	BB	DD	DD	DD	DD	DD
47	84	AA	BB	BB	BB	BB	BB	DD	DD	DD	DD	DD	DD
47	96	AA	BB	BB	BB	BB	DD	DD	DD	DD	DD	EE	FF
53	21	AA	AA	AA	AA	AA	AA	AA	AA	AA	AA	AA	AA
53	29	AA	AA	AA	AA	AA	AA	AA	AA	BB	BB	BB	BB
53	33	AA	AA	AA	AA	AA	AA	BB	BB	BB	BB	BB	BB
53	37	AA	AA	AA	AA	AA	BB	BB	BB	BB	BB	BB	BB
53	41	AA	AA	AA	AA	AA	BB	BB	BB	BB	BB	BB	BB
53	47	AA	AA	AA	AA	BB	BB	BB	BB	BB	BB	CC	DD
53	53	AA	AA	AA	BB	BB	BB	BB	BB	BB	DD	DD	DD
53	59	AA	AA	BB	BB	BB	BB	BB	CC	DD	DD	DD	DD
53	65	AA	AA	BB	BB	BB	BB	CC	DD	DD	DD	DD	DD
53	77	AA	BB	BB	BB	BB	DD	DD	DD	DD	DD	EE	FF
53	84	BB	BB	BB	BB	DD	DD	DD	DD	DD	EE	FF	FF
53	96	BB	BB	BB	DD	DD	DD	DD	EE	FF	FF	FF	FF
59	17	AA	AA	AA	AA	AA	AA	AA	AA	AA	AA	AA	AA
59	21	AA	AA	AA	AA	AA	AA	AA	AA	AA	BB	BB	BB
59	29	AA	AA	AA	AA	AA	AA	BB	BB	BB	BB	BB	BB
59	33	AA	AA	AA	AA	AA	BB	BB	BB	BB	BB	BB	BB
59	37	AA	AA	AA	AA	BB	BB	BB	BB	BB	BB	CC	DD
59	41	AA	AA	AA	BB	BB	BB	BB	BB	BB	DD	DD	DD
59	47	AA	AA	BB	BB	BB	BB	BB	BB	DD	DD	DD	DD
59	53	AA	AA	BB	BB	BB	BB	CC	DD	DD	DD	DD	DD
59	59	AA	BB	BB	BB	BB	CC	DD	DD	DD	DD	EE	EE
59	65	AA	BB	BB	BB	CC	DD	DD	DD	DD	EE	FF	FF
59	77	BB	BB	BB	DD	DD	DD	DD	EE	FF	FF	FF	FF
59	84	BB	BB	BB	DD	DD	DD	EE	FF	FF	FF	FF	FF
65	17	AA	AA	AA	AA	AA	AA	AA	AA	AA	BB	BB	BB
65	21	AA	AA	AA	AA	AA	AA	AA	BB	BB	BB	BB	BB
65	29	AA	AA	AA	AA	BB	BB	BB	BB	BB	BB	BB	CC
65	33	AA	AA	AA	BB	BB	BB	BB	BB	BB	CC	DD	DD
65	37	AA	AA	BB	BB	BB	BB	BB	DD	DD	DD	DD	DD
65	41	AA	AA	BB	BB	BB	BB	BB	DD	DD	DD	DD	DD
65	47	AA	BB	BB	BB	BB	BB	DD	DD	DD	DD	DD	EE
65	53	AA	BB	BB	BB	BB	DD	DD	DD	DD	EE	FF	FF
65	59	BB	BB	BB	BB	DD	DD	DD	DD	EE	FF	FF	FF
65	65	BB	BB	BB	DD	DD	DD	DD	EE	FF	FF	FF	FF
65	77	BB	BB	DD	DD	DD	EE	FF	FF	FF	FF	GG	GG
65	84	BB	BB	DD	DD	DD	FF	FF	FF	FF	GG	GG	HH
71	17	AA	AA	AA	AA	AA	AA	AA	BB	BB	BB	BB	BB

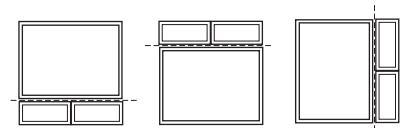

- All reinforcing mullions must be properly secured at ends. Wall framing around window opening must be adequate to withstand wind loads transferred from window composite and reinforcing mullions.
- Do not use these accessories or mullions for structural vertical loading. Reinforcing mullions are for wind loading only.
- If mullion length or load factor exceed chart values, please contact your local Pella sales representative.
- Design charts are not valid for locations where impact forces from airborne debris must be considered.
- To determine allowable mullion wind load for  $L/175 \leq .75"$  deflection go to page D-2 for instructions.

Chart 1 of 2

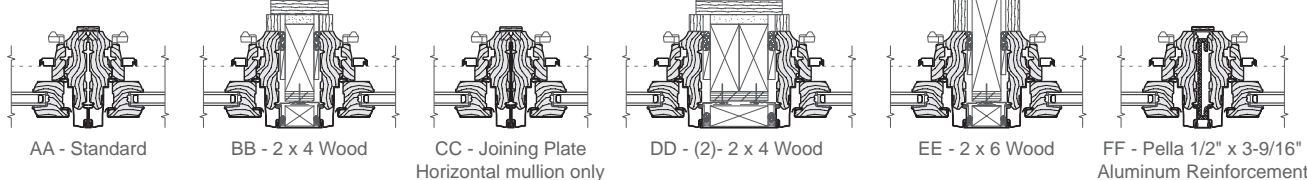

AA - Standard      BB - 2 x 4 Wood      CC - Joining Plate Horizontal mullion only      DD - (2)- 2 x 4 Wood      EE - 2 x 6 Wood      FF - Pella 1/2" x 3-9/16" Aluminum Reinforcement



# Clad-Wood Combinations

## Non-Factory Assembled Three-Way Joint - Window to Windows Load Chart

L	W	20	25	30	35	40	45	50	55	60	65	70	75
(In)	(In)	Maximum Allowable Design Pressure (PSF)											
71	21	AA	AA	AA	AA	AA	BB	BB	BB	BB	BB	BB	BB
71	29	AA	AA	AA	BB	BB	BB	BB	BB	BB	DD	DD	DD
71	33	AA	AA	BB	BB	BB	BB	BB	CC	DD	DD	DD	DD
71	37	AA	BB	BB	BB	BB	BB	DD	DD	DD	DD	DD	DD
71	41	AA	BB	BB	BB	BB	DD	DD	DD	DD	DD	EE	FF
71	47	BB	BB	BB	BB	DD	DD	DD	DD	DD	EE	FF	FF
71	53	BB	BB	BB	DD	DD	DD	DD	EE	FF	FF	FF	FF
71	59	BB	BB	BB	DD	DD	DD	EE	FF	FF	FF	FF	FF
71	65	BB	BB	DD	DD	DD	EE	FF	FF	FF	FF	GG	GG
77	17	AA	AA	AA	AA	AA	BB	BB	BB	BB	BB	BB	BB
77	21	AA	AA	AA	BB	BB	BB	BB	BB	BB	BB	DD	DD
77	29	AA	AA	BB	BB	BB	BB	BB	DD	DD	DD	DD	DD
77	33	AA	BB	BB	BB	BB	DD	DD	DD	DD	DD	EE	EE
77	37	BB	BB	BB	BB	DD	DD	DD	DD	EE	EE	EE	FF
77	41	BB	BB	BB	BB	DD	DD	DD	EE	EE	FF	FF	FF
77	47	BB	BB	BB	DD	DD	DD	EE	EE	FF	FF	FF	FF
77	53	BB	BB	DD	DD	DD	EE	FF	FF	FF	FF	GG	GG
77	59	BB	DD	DD	DD	EE	FF	FF	FF	FF	GG	GG	HH
77	65	BB	DD	DD	EE	EE	FF	FF	FF	GG	GG	HH	HH
84	17	AA	AA	AA	BB	BB	BB	BB	BB	BB	BB	DD	DD
84	21	AA	AA	BB	BB	BB	BB	BB	DD	DD	DD	DD	DD
84	29	BB	BB	BB	BB	DD	DD	DD	DD	EE	EE	EE	EE
84	33	BB	BB	BB	DD	DD	DD	DD	EE	EE	EE	FF	FF
84	37	BB	BB	BB	DD	DD	DD	EE	EE	FF	FF	FF	FF
84	41	BB	BB	DD	DD	DD	EE	EE	FF	FF	FF	GG	GG
84	47	BB	DD	DD	DD	EE	EE	FF	FF	GG	GG	GG	GG
84	53	BB	DD	DD	EE	EE	FF	FF	GG	GG	GG	HH	HH
84	59	DD	DD	EE	EE	FF	FF	GG	GG	GG	HH	HH	II
84	65	DD	DD	EE	FF	FF	GG	GG	GG	HH	II	II	II
96	17	AA	BB	BB	BB	BB	DD	DD	DD	DD	DD	EE	EE
96	21	BB	BB	BB	BB	DD	DD	DD	EE	EE	EE	EE	EE
96	29	BB	BB	DD	DD	EE	EE	EE	EE	FF	FF	GG	GG
96	33	BB	DD	DD	EE	EE	EE	EE	FF	GG	GG	GG	GG
96	37	BB	DD	DD	EE	EE	EE	FF	GG	GG	GG	GG	GG
96	41	DD	DD	EE	EE	EE	FF	GG	GG	GG	GG	HH	II
96	47	DD	EE	EE	EE	FF	GG	GG	GG	HH	II	II	II
96	53	DD	EE	EE	FF	GG	GG	GG	HH	II	II	II	II
96	59	EE	EE	FF	GG	GG	GG	HH	II	II	II	II	KK
96	65	EE	EE	GG	GG	GG	HH	II	II	II	KK	KK	KK
108	17	BB	BB	BB	DD	DD	DD	EE	EE	EE	EE	EE	EE
108	21	BB	BB	DD	DD	EE	EE	EE	EE	EE	GG	GG	GG
108	29	DD	DD	EE	EE	EE	EE	GG	GG	GG	GG	HH	II
108	33	DD	EE	EE	EE	FF	GG	GG	GG	HH	II	II	II
108	37	DD	EE	EE	EE	GG	GG	GG	HH	II	II	II	II
108	41	EE	EE	EE	GG	GG	GG	HH	II	II	II	II	JJ
108	47	EE	EE	GG	GG	GG	HH	II	II	II	JJ	KK	KK
108	53	EE	FF	GG	GG	HH	II	II	II	JJ	KK	KK	KK
108	59	EE	GG	GG	HH	II	II	II	KK	KK	KK	KK	KK
108	65	EE	GG	GG	II	II	II	KK	KK	KK	KK	KK	KK

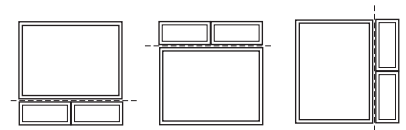

- All reinforcing mullions must be properly secured at ends. Wall framing around window opening must be adequate to withstand wind loads transferred from window composite and reinforcing mullions.
- Do not use these accessories or mullions for structural vertical loading. Reinforcing mullions are for wind loading only.
- If mullion length or load factor exceed chart values, please contact your local Pella sales representative.
- Design charts are not valid for locations where impact forces from airborne debris must be considered.
- To determine allowable mullion wind load for  $L/175 \leq .75$ " deflection go to page D-2 for instructions.

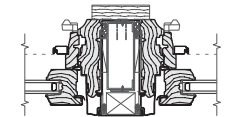

GG - 18 ga. 1-3/8" x 3-5/8"  
Nested Steel Stud

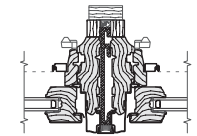

HH - Pella 1/2" x 4-9/16"  
Aluminum Reinforcement

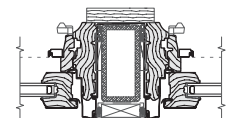

II - 2" x 4" x 1/4"  
Aluminum Tube

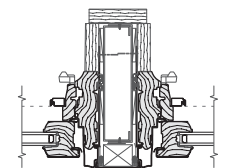

JJ - 20 ga. 1-3/8" x 6"  
Nested Steel Stud

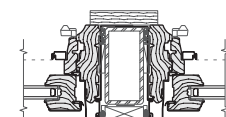

KK - 2" x 4" x 3/16"  
Steel Tube

Chart 2 of 2



# Clad-Wood Combinations

## Non-Factory Assembled Four-Way Joint - Window to Window Load Chart

L	W	20	25	30	35	40	45	50	55	60	65	70	75
(In)	(In)	Maximum Allowable Design Pressure (PSF)											
34	53	BB	BB	BB	BB	BB	BB	BB	BB	BB	BB	BB	CC
34	59	BB	BB	BB	BB	BB	BB	BB	BB	BB	CC	CC	CC
34	65	BB	BB	BB	BB	BB	BB	BB	BB	CC	CC	CC	CC
34	71	BB	BB	BB	BB	BB	BB	BB	CC	CC	CC	CC	CC
34	77	BB	BB	BB	BB	BB	BB	CC	CC	CC	CC	CC	CC
34	84	BB	BB	BB	BB	BB	BB	CC	CC	CC	CC	CC	CC
34	96	BB	BB	BB	BB	CC	CC	CC	CC	CC	CC	CC	CC
34	108	BB	BB	BB	BB	CC	CC	CC	CC	CC	CC	CC	DD
42	37	BB	BB	BB	BB	BB	BB	BB	BB	BB	BB	CC	CC
42	41	BB	BB	BB	BB	BB	BB	BB	BB	BB	CC	CC	CC
42	47	BB	BB	BB	BB	BB	BB	BB	CC	CC	CC	CC	CC
42	53	BB	BB	BB	BB	BB	BB	CC	CC	CC	CC	CC	CC
42	59	BB	BB	BB	BB	BB	CC	CC	CC	CC	CC	CC	CC
42	65	BB	BB	BB	BB	CC	CC	CC	CC	CC	CC	CC	CC
42	71	BB	BB	BB	CC	CC	CC	CC	CC	CC	CC	CC	DD
42	77	BB	BB	BB	CC	CC	CC	CC	CC	CC	CC	DD	EE
42	84	BB	BB	CC	CC	CC	CC	CC	CC	CC	EE	EE	FF
42	96	BB	BB	CC	CC	CC	CC	CC	DD	EE	FF	FF	FF
42	108	BB	CC	CC	CC	CC	CC	DD	EE	FF	FF	FF	FF
50	25	BB	BB	BB	BB	BB	BB	BB	BB	BB	BB	BB	CC
50	29	BB	BB	BB	BB	BB	BB	BB	BB	BB	CC	CC	CC
50	33	BB	BB	BB	BB	BB	BB	BB	CC	CC	CC	CC	CC
50	37	BB	BB	BB	BB	BB	BB	CC	CC	CC	CC	CC	CC
50	41	BB	BB	BB	BB	BB	CC	CC	CC	CC	CC	CC	CC
50	47	BB	BB	BB	BB	CC	CC	CC	CC	CC	CC	CC	CC
50	53	BB	BB	BB	CC	CC	CC	CC	CC	CC	CC	DD	EE
50	59	BB	BB	CC	CC	CC	CC	CC	CC	CC	DD	EE	FF
50	65	BB	BB	CC	CC	CC	CC	CC	CC	EE	EE	FF	FF
50	71	BB	CC	CC	CC	CC	CC	CC	EE	EE	FF	FF	FF
50	77	BB	CC	CC	CC	CC	CC	EE	EE	FF	FF	FF	FF
50	84	BB	CC	CC	CC	CC	DD	EE	FF	FF	FF	FF	FF
50	96	CC	CC	CC	CC	EE	EE	FF	FF	FF	FF	FF	GG
50	108	CC	CC	CC	DD	EE	FF	FF	FF	FF	FF	GG	GG
58	21	BB	BB	BB	BB	BB	BB	BB	BB	BB	CC	CC	CC
58	25	BB	BB	BB	BB	BB	BB	BB	CC	CC	CC	CC	CC
58	29	BB	BB	BB	BB	BB	CC	CC	CC	CC	CC	CC	CC
58	33	BB	BB	BB	BB	CC	CC	CC	CC	CC	CC	CC	CC
58	37	BB	BB	BB	BB	CC	CC	CC	CC	CC	CC	CC	DD
58	41	BB	BB	BB	CC	CC	CC	CC	CC	CC	CC	EE	EE
58	47	BB	BB	CC	CC	CC	CC	CC	CC	DD	EE	FF	FF
58	53	BB	CC	CC	CC	CC	CC	CC	EE	EE	FF	FF	FF
58	59	BB	CC	CC	CC	CC	CC	EE	FF	FF	FF	FF	FF
58	65	BB	CC	CC	CC	CC	EE	FF	FF	FF	FF	FF	FF
58	71	CC	CC	CC	CC	DD	EE	FF	FF	FF	FF	FF	GG
58	77	CC	CC	CC	CC	EE	FF	FF	FF	FF	FF	GG	GG
58	84	CC	CC	CC	EE	FF	FF	FF	FF	FF	GG	GG	HH
58	96	CC	CC	EE	FF	FF	FF	FF	GG	GG	HH	HH	HH
58	108	CC	CC	FF	FF	FF	FF	GG	GG	HH	HH	II	II
66	17	BB	BB	BB	BB	BB	BB	BB	BB	CC	CC	CC	CC

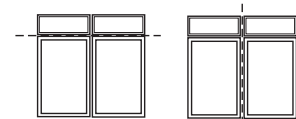

- All reinforcing mullions must be properly secured at ends. Wall framing around window opening must be adequate to withstand wind loads transferred from window composite and reinforcing mullions.
- Do not use these accessories or mullions for structural vertical loading. Reinforcing mullions are for wind loading only.
- If mullion length or load factor exceed chart values, please contact your local Pella sales representative.
- Design charts are not valid for locations where impact forces from airborne debris must be considered.
- To determine allowable mullion wind load for  $L/175 \leq .75"$  deflection go to page D-2 for instructions.

Chart 1 of 2

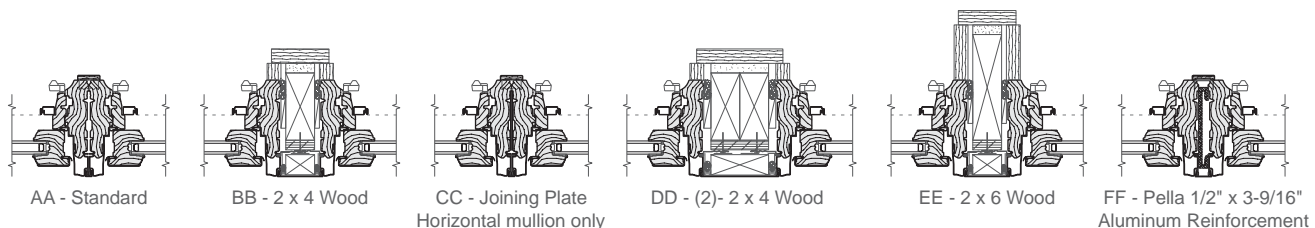



# Clad-Wood Combinations

## Non-Factory Assembled Four-Way Joint - Window to Window Load Chart

L	W	20	25	30	35	40	45	50	55	60	65	70	75
(In)	(In)	Maximum Allowable Design Pressure (PSF)											
66	21	BB	BB	BB	BB	BB	BB	CC	CC	CC	CC	CC	CC
66	25	BB	BB	BB	BB	BB	CC	CC	CC	CC	CC	CC	CC
66	29	BB	BB	BB	CC	CC	CC	CC	CC	CC	CC	CC	DD
66	33	BB	BB	BB	CC	CC	CC	CC	CC	CC	DD	EE	EE
66	37	BB	BB	CC	CC	CC	CC	CC	CC	EE	EE	FF	FF
66	41	BB	CC	CC	CC	CC	CC	CC	EE	EE	FF	FF	FF
66	47	BB	CC	CC	CC	CC	CC	EE	FF	FF	FF	FF	FF
66	53	CC	CC	CC	CC	CC	EE	FF	FF	FF	FF	FF	FF
66	59	CC	CC	CC	CC	EE	FF	FF	FF	FF	FF	GG	GG
66	65	CC	CC	CC	EE	FF	FF	FF	FF	FF	GG	GG	HH
66	71	CC	CC	DD	FF	FF	FF	FF	FF	GG	GG	HH	HH
66	77	CC	CC	EE	FF	FF	FF	FF	GG	GG	HH	HH	II
66	84	CC	CC	FF	FF	FF	FF	GG	GG	HH	HH	II	II
66	96	CC	EE	FF	FF	FF	GG	GG	HH	II	II	II	II
66	108	DD	FF	FF	FF	GG	HH	HH	II	II	II	II	II
74	17	BB	BB	BB	BB	BB	BB	CC	CC	CC	CC	CC	CC
74	21	BB	BB	BB	BB	CC	CC	CC	CC	CC	CC	CC	CC
74	25	BB	BB	BB	CC	CC	CC	CC	CC	CC	CC	EE	EE
74	29	BB	BB	CC	CC	CC	CC	CC	CC	EE	EE	FF	FF
74	33	BB	CC	CC	CC	CC	CC	DD	EE	FF	FF	FF	FF
74	37	BB	CC	CC	CC	CC	DD	EE	FF	FF	FF	FF	FF
74	41	CC	CC	CC	CC	DD	EE	FF	FF	FF	FF	FF	FF
74	47	CC	CC	CC	DD	EE	FF	FF	FF	FF	FF	GG	GG
74	53	CC	CC	CC	EE	FF	FF	FF	FF	FF	GG	GG	HH
74	59	CC	CC	EE	FF	FF	FF	FF	FF	GG	GG	GG	HH
74	65	CC	CC	EE	FF	FF	FF	FF	GG	HH	HH	II	II
74	71	CC	EE	FF	FF	FF	FF	GG	HH	HH	II	II	II
74	77	CC	EE	FF	FF	FF	GG	GG	HH	II	II	II	II
74	84	EE	FF	FF	FF	GG	GG	HH	II	II	II	II	II
88	17	BB	BB	CC	CC	CC	CC	CC	CC	EE	EE	EE	EE
88	21	BB	CC	CC	CC	CC	CC	EE	EE	EE	EE	FF	FF
88	25	CC	CC	CC	CC	EE	EE	EE	EE	FF	FF	FF	FF
88	29	CC	CC	CC	EE	EE	EE	FF	FF	FF	FF	GG	GG
88	33	CC	CC	DD	EE	EE	FF	FF	FF	GG	GG	GG	GG
88	37	CC	CC	EE	EE	FF	FF	FF	GG	GG	GG	GG	HH
88	41	CC	EE	EE	FF	FF	FF	GG	GG	GG	GG	HH	HH
88	47	CC	EE	FF	FF	FF	GG	GG	GG	HH	HH	II	II
88	53	EE	EE	FF	FF	GG	GG	GG	HH	HH	II	II	II
88	59	EE	FF	FF	GG	GG	GG	HH	II	II	II	II	II
88	65	EE	FF	FF	GG	GG	GG	HH	II	II	II	II	II
88	71	FF	FF	GG	GG	HH	HH	II	II	II	II	II	KK
97	17	BB	CC	CC	CC	CC	EE	EE	EE	EE	EE	FF	FF
97	21	CC	CC	CC	DD	EE	EE	EE	FF	FF	FF	GG	GG
97	25	CC	CC	EE	EE	EE	EE	FF	FF	GG	GG	GG	GG
97	29	CC	CC	EE	EE	FF	FF	FF	GG	GG	GG	GG	GG
97	33	CC	EE	EE	FF	FF	GG	GG	GG	GG	GG	HH	HH
97	37	DD	EE	EE	FF	GG	GG	GG	GG	GG	HH	II	II
97	41	EE	EE	FF	FF	GG	GG	GG	HH	HH	II	II	II
97	47	EE	FF	FF	GG	GG	GG	HH	II	II	II	II	II
97	53	EE	FF	GG	GG	GG	HH	II	II	II	II	II	KK
97	59	FF	GG	GG	GG	HH	II	II	II	II	KK	KK	KK
97	65	FF	GG	GG	GG	HH	II	II	II	KK	KK	KK	KK
108	17	CC	CC	CC	EE	EE	EE	EE	FF	FF	GG	GG	GG
108	21	CC	CC	EE	EE	EE	FF	FF	GG	GG	GG	GG	GG
108	25	CC	EE	EE	EE	FF	GG	GG	GG	GG	GG	HH	II
108	29	EE	EE	EE	FF	GG	GG	GG	GG	HH	II	II	II
108	33	EE	EE	FF	GG	GG	GG	GG	HH	II	II	II	II
108	37	EE	EE	GG	GG	GG	GG	HH	II	II	II	II	JJ
108	41	EE	FF	GG	GG	GG	HH	II	II	II	II	KK	KK
108	47	FF	GG	GG	GG	II	II	II	II	JJ	KK	KK	KK
108	53	FF	GG	GG	HH	II	II	II	KK	KK	KK	KK	KK
108	59	GG	GG	HH	II	II	II	KK	KK	KK	KK	KK	KK
108	65	GG	GG	II	II	II	KK	KK	KK	KK	KK	KK	KK

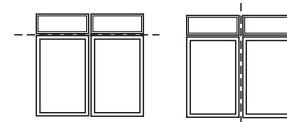

- All reinforcing mullions must be properly secured at ends. Wall framing around window opening must be adequate to withstand wind loads transferred from window composite and reinforcing mullions.
- Do not use these accessories or mullions for structural vertical loading. Reinforcing mullions are for wind loading only.
- If mullion length or load factor exceed chart values, please contact your local Pella sales representative.
- Design charts are not valid for locations where impact forces from airborne debris must be considered.
- To determine allowable mullion wind load for  $L/175 \leq .75$ " deflection go to page D-2 for instructions.

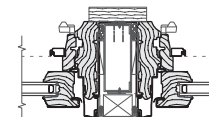

GG - 18 ga. 1-3/8" x 3-5/8"  
Nested Steel Stud

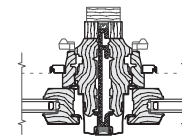

HH - Pella 1/2" x 4-9/16"  
Aluminum Reinforcement

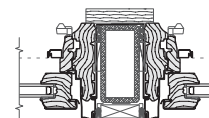

II - 2" x 4" x 1/4"  
Aluminum Tube

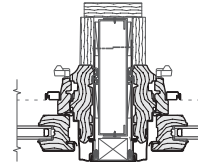

JJ - 20 ga. 1-3/8" x 6"  
Nested Steel Stud

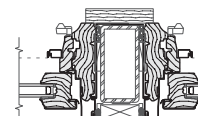

KK - 2" x 4" x 3/16"  
Steel Tube

Chart 2 of 2



# Clad-Wood Combinations

## Non-Factory Assembled Two-Way Joint - Door to Door Load Chart

L	W	20	25	30	35	40	45	50	55	60	65	70	75
(In)	(In)	Maximum Allowable Design Pressure (PSF)											
81	18	AA	AA	AA	AA	AA	AA	AA	AA	AA	AA	AA	AA
81	26	AA	AA	AA	AA	AA	AA	AA	AA	AA	BB	BB	BB
81	30	AA	AA	AA	AA	AA	AA	AA	BB	BB	BB	BB	DD
81	34	AA	AA	AA	AA	AA	AA	BB	BB	BB	BB	DD	DD
81	36	AA	AA	AA	AA	AA	BB	BB	BB	BB	DD	DD	DD
81	38	AA	AA	AA	AA	AA	BB	BB	BB	DD	DD	DD	DD
81	50	AA	AA	AA	BB	BB	DD	DD	DD	EE	EE	EE	EE
81	60	AA	AA	BB	BB	DD	DD	EE	EE	EE	FF	GG	GG
81	67	AA	BB	BB	DD	DD	EE	EE	EE	FF	GG	GG	GG
81	72	AA	BB	BB	DD	EE	EE	EE	FF	GG	GG	GG	GG
81	75	AA	BB	DD	DD	EE	EE	EE	GG	GG	GG	GG	HH
81	96	BB	DD	EE	EE	FF	GG	GG	GG	HH	II	II	II
81	108	BB	DD	EE	EE	GG	GG	GG	HH	II	II	II	KK
81	117	DD	EE	EE	FF	GG	GG	HH	II	II	II	KK	KK
81	141	DD	EE	GG	GG	HH	II	II	II	KK	KK	KK	KK
81	144	EE	EE	GG	GG	HH	II	II	II	KK	KK	KK	KK
81	189	EE	GG	HH	II	II	KK	KK	KK	KK	KK	KK	KK
82	18	AA	AA	AA	AA	AA	AA	AA	AA	AA	AA	AA	AA
82	26	AA	AA	AA	AA	AA	AA	AA	AA	BB	BB	BB	BB
82	30	AA	AA	AA	AA	AA	AA	AA	BB	BB	BB	BB	DD
82	36	AA	AA	AA	AA	AA	BB	BB	BB	DD	DD	DD	DD
82	42	AA	AA	AA	AA	BB	BB	BB	DD	DD	DD	EE	EE
82	50	AA	AA	AA	BB	BB	DD	DD	DD	EE	EE	EE	FF
82	60	AA	AA	BB	BB	DD	DD	EE	EE	EE	FF	GG	GG
82	67	AA	BB	BB	DD	DD	EE	EE	EE	GG	GG	GG	GG
82	72	AA	BB	DD	DD	EE	EE	EE	FF	GG	GG	GG	HH
82	75	AA	BB	DD	DD	EE	EE	FF	GG	GG	GG	GG	HH
82	96	BB	DD	EE	EE	FF	GG	GG	HH	HH	II	II	II
82	108	DD	DD	EE	FF	GG	GG	HH	II	II	II	II	KK
82	117	DD	EE	EE	GG	GG	GG	II	II	II	II	KK	KK
82	141	EE	EE	GG	GG	HH	II	II	KK	KK	KK	KK	KK
82	144	EE	EE	GG	GG	HH	II	II	KK	KK	KK	KK	KK
82	189	FF	GG	HH	II	II	KK	KK	KK	KK	KK	KK	**
86	18	AA	AA	AA	AA	AA	AA	AA	AA	AA	AA	AA	BB
86	26	AA	AA	AA	AA	AA	AA	AA	BB	BB	BB	BB	DD
86	30	AA	AA	AA	AA	AA	BB	BB	BB	BB	DD	DD	DD
86	34	AA	AA	AA	AA	BB	BB	BB	DD	DD	DD	DD	EE
86	36	AA	AA	AA	AA	BB	BB	BB	DD	DD	DD	EE	EE
86	38	AA	AA	AA	AA	BB	BB	DD	DD	DD	EE	EE	EE
86	50	AA	AA	BB	BB	DD	DD	EE	EE	EE	EE	GG	GG
86	60	AA	BB	BB	DD	DD	EE	EE	EE	GG	GG	GG	GG
86	67	BB	BB	DD	DD	EE	EE	EE	GG	GG	GG	HH	II
86	72	BB	BB	DD	EE	EE	EE	GG	GG	GG	GG	II	II
86	75	BB	DD	DD	EE	EE	EE	GG	GG	GG	HH	II	II
86	96	DD	DD	EE	EE	GG	GG	HH	II	II	II	KK	KK
86	108	DD	EE	EE	GG	GG	HH	II	II	II	KK	KK	KK
86	117	DD	EE	GG	GG	GG	II	II	II	KK	KK	KK	KK
86	141	EE	GG	GG	HH	II	II	KK	KK	KK	KK	KK	KK
86	144	EE	GG	GG	II	II	II	KK	KK	KK	KK	KK	KK
86	189	GG	HH	II	II	KK	KK	KK	KK	**	**	**	**

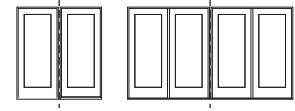

- All reinforcing mullions must be properly secured at ends. Wall framing around window opening must be adequate to withstand wind loads transferred from window composite and reinforcing mullions.
- Do not use these accessories or mullions for structural vertical loading. Reinforcing mullions are for wind loading only.
- If mullion length or load factor exceed chart values, please contact your local Pella sales representative.
- Design charts are not valid for locations where impact forces from airborne debris must be considered.
- To determine allowable mullion wind load for  $L/175 \leq .75"$  deflection go to page D-2 for instructions.

Chart 1 of 2

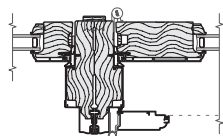

AA - Standard

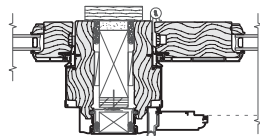

BB - 2 x 4 Wood

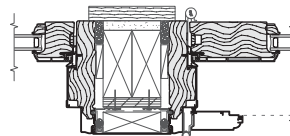

DD - (2)- 2 x 4 Wood

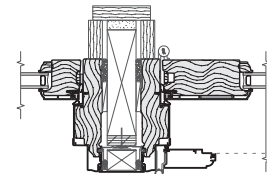

EE - 2 x 6 Wood



# Clad-Wood Combinations

## Non-Factory Assembled Two-Way Joint - Door to Door Load Chart

L	W	20	25	30	35	40	45	50	55	60	65	70	75
(In)	(In)	Maximum Allowable Design Pressure (PSF)											
96	18	AA	AA	AA	AA	AA	AA	AA	BB	BB	BB	BB	DD
96	26	AA	AA	AA	AA	BB	BB	BB	DD	DD	DD	EE	EE
96	30	AA	AA	AA	BB	BB	DD	DD	DD	EE	EE	EE	EE
96	34	AA	AA	BB	BB	DD	DD	DD	EE	EE	EE	EE	GG
96	36	AA	AA	BB	BB	DD	DD	EE	EE	EE	EE	GG	GG
96	38	AA	AA	BB	BB	DD	DD	EE	EE	EE	FF	GG	GG
96	50	BB	BB	DD	EE	EE	EE	GG	GG	GG	GG	HH	II
96	60	BB	DD	EE	EE	EE	GG	GG	GG	HH	II	II	II
96	67	BB	DD	EE	EE	GG	GG	GG	II	II	II	II	JJ
96	72	DD	EE	EE	GG	GG	GG	HH	II	II	II	JJ	KK
96	75	DD	EE	EE	GG	GG	HH	II	II	II	JJ	KK	KK
96	96	EE	EE	GG	GG	II	II	JJ	KK	KK	KK	KK	KK
96	108	EE	GG	GG	II	II	JJ	KK	KK	KK	KK	KK	KK
96	117	EE	GG	HH	II	II	KK	KK	KK	KK	KK	KK	**
96	141	GG	HH	II	JJ	KK	KK	KK	KK	**	**	**	**
96	144	GG	HH	II	JJ	KK	KK	KK	KK	**	**	**	**
96	189	II	II	KK	KK	KK	KK	**	**	**	**	**	**

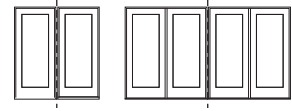

- All reinforcing mullions must be properly secured at ends. Wall framing around window opening must be adequate to withstand wind loads transferred from window composite and reinforcing mullions.
- Do not use these accessories or mullions for structural vertical loading. Reinforcing mullions are for wind loading only.
- If mullion length or load factor exceed chart values, please contact your local Pella sales representative.
- Design charts are not valid for locations where impact forces from airborne debris must be considered.
- To determine allowable mullion wind load for  $L/175 \leq .75"$  deflection go to page D-2 for instructions.

Chart 2 of 2

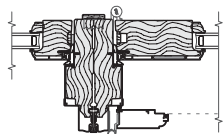

AA - Standard

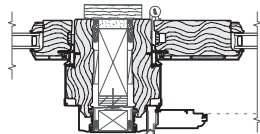

BB - 2 x 4 Wood

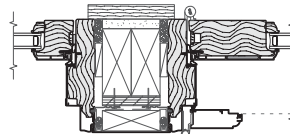

DD - (2) - 2 x 4 Wood

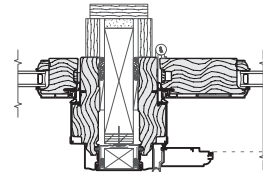

EE - 2 x 6 Wood

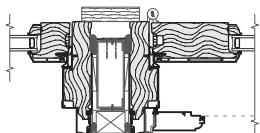

GG - 18 ga. 1-3/8" x 3-5/8" Nested Steel Stud

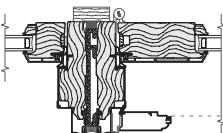

HH - Pella 1/2" x 4-9/16" Aluminum Reinforcement

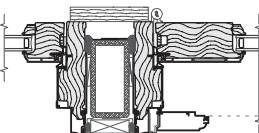

II - 2" x 4" x 1/4" Aluminum Tube

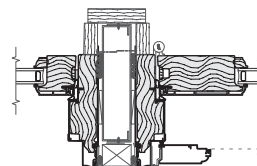

JJ - 20 ga. 1-3/8" x 6" Nested Steel Stud

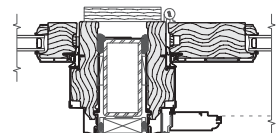

KK - 2" x 4" x 3/16" Steel Tube



# Clad-Wood Combinations

## Non-Factory Assembled Two-Way Joint - Door to Transom Load Chart

L	W	20	25	30	35	40	45	50	55	60	65	70	75
(In)	(In)	Maximum Allowable Design Pressure (PSF)											
81	36	AA	AA	AA	AA	BB	BB	BB	BB	DD	DD	DD	EE
81	42	AA	AA	AA	BB	BB	BB	DD	DD	DD	EE	EE	EE
81	50	AA	AA	BB	BB	BB	DD	DD	EE	EE	EE	FF	FF
81	60	AA	BB	BB	DD	DD	EE	EE	EE	FF	FF	GG	GG
81	67	AA	BB	BB	DD	DD	EE	EE	FF	GG	GG	GG	HH
81	72	BB	BB	DD	DD	EE	EE	FF	GG	GG	GG	HH	HH
81	75	BB	BB	DD	DD	EE	EE	FF	GG	GG	GG	HH	II
81	96	BB	DD	EE	EE	FF	GG	GG	HH	II	II	II	II
81	108	DD	EE	EE	FF	GG	GG	HH	II	II	II	II	KK
81	117	DD	EE	FF	GG	GG	HH	II	II	II	II	KK	KK
81	141	EE	FF	GG	GG	II	II	II	II	KK	KK	KK	KK
81	144	EE	FF	GG	HH	II	II	II	KK	KK	KK	KK	KK
81	189	FF	GG	II	II	II	KK	KK	KK	KK	KK	KK	**
82	36	AA	AA	AA	AA	BB	BB	BB	DD	DD	DD	DD	EE
82	42	AA	AA	AA	BB	BB	BB	DD	DD	DD	EE	EE	EE
82	50	AA	AA	BB	BB	DD	DD	DD	EE	EE	EE	FF	FF
82	60	AA	BB	BB	DD	DD	EE	EE	EE	FF	GG	GG	GG
82	67	AA	BB	DD	DD	EE	EE	EE	FF	GG	GG	GG	HH
82	72	BB	BB	DD	DD	EE	EE	FF	GG	GG	GG	HH	HH
82	75	BB	BB	DD	EE	EE	FF	FF	GG	GG	GG	HH	II
82	96	BB	DD	EE	FF	GG	GG	GG	HH	II	II	II	II
82	108	DD	EE	EE	FF	GG	GG	HH	II	II	II	KK	KK
82	117	DD	EE	FF	GG	GG	HH	II	II	II	KK	KK	KK
82	141	EE	FF	GG	HH	II	II	II	KK	KK	KK	KK	KK
82	144	EE	FF	GG	HH	II	II	II	KK	KK	KK	KK	KK
82	189	FF	GG	II	II	II	KK	KK	KK	KK	KK	KK	**
86	36	AA	AA	AA	BB	BB	BB	DD	DD	DD	EE	EE	EE
86	42	AA	AA	BB	BB	BB	DD	DD	EE	EE	EE	EE	FF
86	50	AA	BB	BB	DD	DD	DD	EE	EE	EE	FF	GG	GG
86	60	BB	BB	DD	DD	EE	EE	EE	GG	GG	GG	GG	HH
86	67	BB	BB	DD	EE	EE	EE	GG	GG	GG	GG	HH	II
86	72	BB	DD	DD	EE	EE	FF	GG	GG	GG	HH	II	II
86	75	BB	DD	DD	EE	EE	GG	GG	GG	HH	II	II	II
86	96	DD	EE	EE	GG	GG	GG	HH	II	II	II	KK	KK
86	108	DD	EE	FF	GG	GG	HH	II	II	II	KK	KK	KK
86	117	EE	EE	GG	GG	HH	II	II	II	KK	KK	KK	KK
86	141	EE	GG	GG	II	II	II	KK	KK	KK	KK	KK	KK
86	144	EE	GG	GG	II	II	II	KK	KK	KK	KK	KK	KK
86	189	GG	HH	II	KK	KK	KK	KK	KK	KK	**	**	**

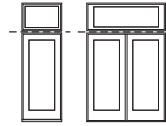

- All reinforcing mullions must be properly secured at ends. Wall framing around window opening must be adequate to withstand wind loads transferred from window composite and reinforcing mullions.
- Do not use these accessories or mullions for structural vertical loading. Reinforcing mullions are for wind loading only.
- If mullion length or load factor exceed chart values, please contact your local Pella sales representative.
- Design charts are not valid for locations where impact forces from airborne debris must be considered.
- To determine allowable mullion wind load for  $L/175 \leq .75"$  deflection go to page D-2 for instructions.

Chart 1 of 2

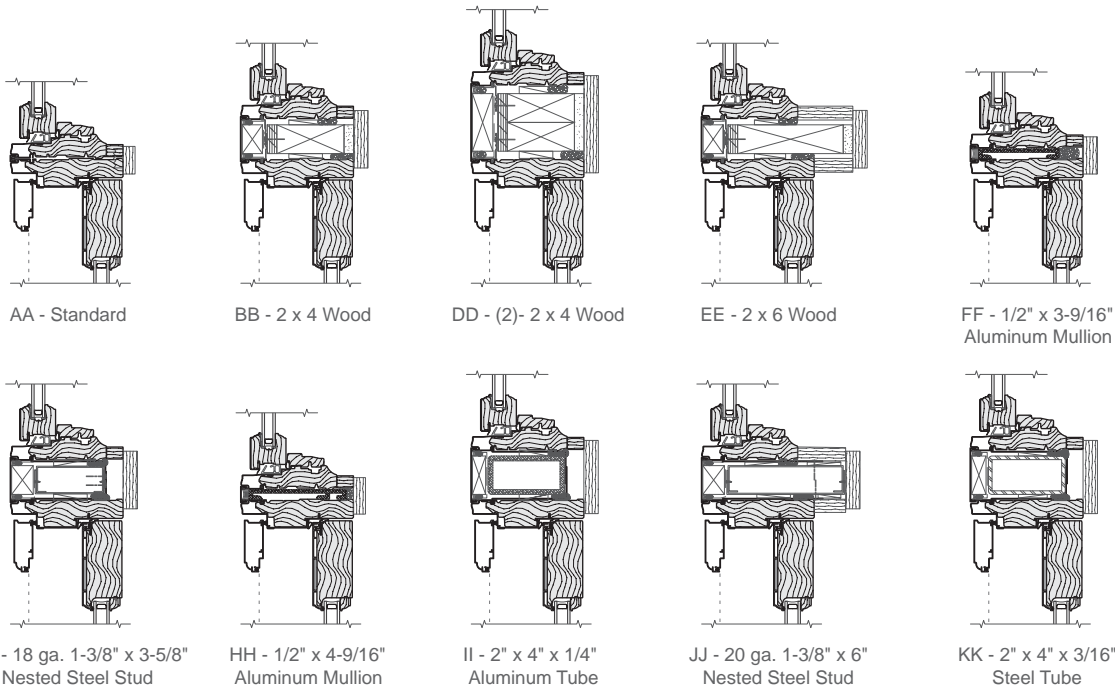



# Clad-Wood Combinations

## Non-Factory Assembled Two-Way Joint - Door to Transom Load Chart

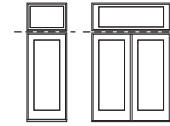

L	W	20	25	30	35	40	45	50	55	60	65	70	75
(In)	(In)	Maximum Allowable Design Pressure (PSF)											
96	36	AA	BB	BB	DD	DD	DD	EE	EE	EE	EE	GG	GG
96	42	AA	BB	DD	DD	EE	EE	EE	EE	GG	GG	GG	GG
96	50	BB	DD	DD	EE	EE	EE	GG	GG	GG	GG	HH	II
96	60	BB	DD	EE	EE	GG	GG	GG	HH	II	II	II	II
96	67	DD	EE	EE	FF	GG	GG	HH	II	II	II	JJ	KK
96	72	DD	EE	EE	GG	GG	GG	II	II	II	II	KK	KK
96	75	DD	EE	EE	GG	GG	HH	II	II	II	KK	KK	KK
96	96	EE	GG	GG	HH	II	II	JJ	KK	KK	KK	KK	KK
96	108	EE	GG	GG	II	II	JJ	KK	KK	KK	KK	KK	KK
96	117	EE	GG	II	II	II	KK	KK	KK	KK	KK	KK	**
96	141	GG	II	II	KK	KK	KK	KK	KK	**	**	**	**
96	144	GG	II	II	KK	KK	KK	KK	KK	**	**	**	**
96	189	II	JJ	KK	KK	KK	**	**	**	**	**	**	**
117	48	EE	EE	GG	GG	HH	II	II	JJ	JJ	JJ	KK	KK
117	50	EE	EE	GG	GG	II	II	II	JJ	JJ	JJ	KK	KK
117	54	EE	GG	GG	HH	II	II	JJ	JJ	JJ	KK	KK	KK
117	55	EE	GG	GG	HH	II	II	JJ	JJ	KK	KK	KK	KK
117	57	EE	GG	GG	II	II	II	JJ	JJ	KK	KK	KK	KK
117	61	EE	GG	HH	II	II	JJ	JJ	KK	KK	KK	KK	KK
141	48	GG	II	II	JJ	JJ	JJ	KK	KK	**	**	**	**
141	50	GG	II	JJ	JJ	JJ	KK	KK	**	**	**	**	**
141	54	HH	II	JJ	JJ	JJ	KK	**	**	**	**	**	**
141	55	HH	II	JJ	JJ	JJ	KK	**	**	**	**	**	**
141	57	II	II	JJ	JJ	KK	KK	**	**	**	**	**	**
141	61	II	JJ	JJ	JJ	KK	**	**	**	**	**	**	**
144	48	GG	II	JJ	JJ	JJ	KK	KK	**	**	**	**	**
144	50	HH	II	JJ	JJ	JJ	KK	**	**	**	**	**	**
144	54	II	II	JJ	JJ	KK	KK	**	**	**	**	**	**
144	55	II	II	JJ	JJ	KK	KK	**	**	**	**	**	**
144	57	II	JJ	JJ	JJ	KK	**	**	**	**	**	**	**
144	61	II	JJ	JJ	KK	KK	**	**	**	**	**	**	**

- All reinforcing mullions must be properly secured at ends. Wall framing around window opening must be adequate to withstand wind loads transferred from window composite and reinforcing mullions.
- Do not use these accessories or mullions for structural vertical loading. Reinforcing mullions are for wind loading only.
- If mullion length or load factor exceed chart values, please contact your local Pella sales representative.
- Design charts are not valid for locations where impact forces from airborne debris must be considered.
- To determine allowable mullion wind load for  $L/175 \leq .75$ " deflection go to page D-2 for instructions.

Chart 2 of 2

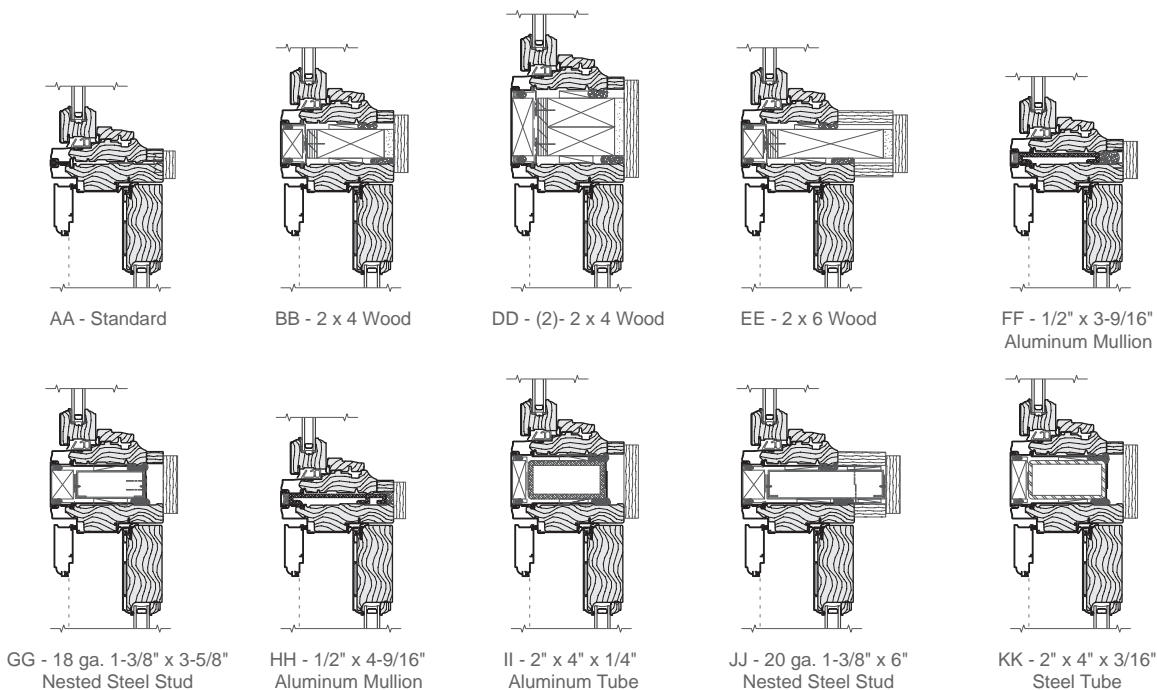





# Clad-Wood Combinations

## Non-Factory Assembled Three-Way Joint - Door to Transom Load Chart

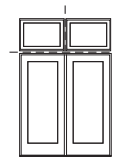

L	W	20	25	30	35	40	45	50	55	60	65	70	75
(In)	(In)	Maximum Allowable Design Pressure (PSF)											
81	48	BB	BB	DD	DD	DD	EE	EE	EE	FF	FF	GG	GG
81	50	BB	BB	DD	DD	DD	EE	EE	EE	FF	FF	GG	GG
81	54	BB	BB	DD	DD	DD	EE	EE	EE	FF	FF	GG	GG
81	55	BB	BB	DD	DD	DD	EE	EE	EE	FF	FF	GG	GG
81	57	BB	BB	DD	DD	DD	EE	EE	EE	FF	FF	GG	GG
81	61	BB	DD	DD	EE	EE	FF	FF	GG	GG	GG	GG	HH
82	48	BB	BB	DD	DD	DD	EE	EE	EE	FF	FF	GG	GG
82	50	BB	BB	DD	DD	DD	EE	EE	EE	FF	FF	GG	GG
82	54	BB	BB	DD	DD	DD	EE	EE	EE	FF	FF	GG	GG
82	55	BB	BB	DD	DD	DD	EE	EE	EE	FF	FF	GG	GG
82	57	BB	DD	DD	DD	DD	EE	EE	EE	FF	FF	GG	GG
82	61	BB	DD	DD	EE	EE	FF	FF	GG	GG	GG	GG	HH
86	48	BB	BB	DD	DD	DD	EE	EE	EE	FF	GG	GG	GG
86	50	BB	DD	DD	EE	EE	EE	FF	FF	GG	GG	GG	GG
86	54	BB	DD	DD	EE	EE	EE	FF	FF	GG	GG	GG	GG
86	55	BB	DD	DD	EE	EE	EE	FF	FF	GG	GG	GG	HH
86	57	BB	DD	DD	EE	EE	EE	FF	GG	GG	GG	GG	HH
86	61	DD	DD	EE	EE	FF	FF	GG	GG	GG	GG	HH	HH
96	48	DD	DD	EE	EE	EE	GG	GG	GG	GG	HH	II	II
96	50	DD	EE	EE	EE	GG	GG	GG	GG	HH	II	II	II
96	54	DD	EE	EE	EE	GG	GG	GG	HH	II	II	II	II
96	55	DD	EE	EE	EE	GG	GG	GG	HH	II	II	II	II
96	57	DD	EE	EE	GG	GG	GG	GG	GG	II	II	II	II
96	61	DD	EE	EE	GG	GG	GG	HH	II	II	II	II	KK
117	48	EE	GG	GG	HH	II	II	JJ	JJ	JJ	KK	KK	KK
117	50	EE	GG	GG	II	II	II	JJ	JJ	KK	KK	KK	KK
117	54	EE	GG	HH	II	II	II	JJ	JJ	KK	KK	KK	KK
117	55	FF	GG	HH	II	II	II	JJ	JJ	KK	KK	KK	KK
117	57	GG	GG	HH	II	II	II	JJ	JJ	KK	KK	KK	KK
117	61	GG	GG	II	II	JJ	JJ	KK	KK	KK	KK	KK	**
141	48	II	II	JJ	JJ	JJ	KK	**	**	**	**	**	**
141	50	II	II	JJ	JJ	KK	KK	**	**	**	**	**	**
141	54	II	JJ	JJ	JJ	KK	**	**	**	**	**	**	**
141	55	II	JJ	JJ	JJ	KK	**	**	**	**	**	**	**
141	57	II	JJ	JJ	KK	KK	**	**	**	**	**	**	**
141	61	II	JJ	JJ	KK	**	**	**	**	**	**	**	**
144	48	II	JJ	JJ	JJ	KK	KK	**	**	**	**	**	**
144	50	II	JJ	JJ	JJ	KK	**	**	**	**	**	**	**
144	54	II	JJ	JJ	KK	KK	**	**	**	**	**	**	**
144	55	II	JJ	JJ	KK	**	**	**	**	**	**	**	**
144	57	II	JJ	JJ	KK	**	**	**	**	**	**	**	**
144	61	JJ	JJ	KK	KK	**	**	**	**	**	**	**	**

- All reinforcing mullions must be properly secured at ends. Wall framing around window opening must be adequate to withstand wind loads transferred from window composite and reinforcing mullions.
- Do not use these accessories or mullions for structural vertical loading. Reinforcing mullions are for wind loading only.
- If mullion length or load factor exceed chart values, please contact your local Pella sales representative.
- Design charts are not valid for locations where impact forces from airborne debris must be considered.
- To determine allowable mullion wind load for  $L/175 \leq .75"$  deflection go to page D-2 for instructions.

