



General Information

Introduction COMB-2

Design Considerations and Examples..... COMB-3

Combination Assembly Recommendations and Limitations

Composite Configurations..... COMB-4

Typical Sealant Recommendations..... COMB-5

Single-Unit Openings COMB-5

Two-Way Window Combinations COMB-7

Three-Way Window Combinations COMB-9

Four-Way Window Combinations COMB-10

Sample Calculations COMB-12

Factory and Non-Factory Assembled Combinations.....COMB-15

Document Navigation Tips:

Items listed in the table of contents above are active links that will take you to the corresponding page.
 The Pella logo on each page is a link back to this table of contents.
 Bookmarks are also included in this PDF document and are available as an additional navigation option.

The information published in this document is believed to be accurate at the time of publication. However, because we are constantly working to improve our products, specifications are subject to change without notice. Consult your local Pella representative for up-to-date product information.



This section explores the opportunities, requirements and limitations related to joining various combinations of standard Pella® 250 Series windows.

IMPORTANT:

Determining and meeting the structural load requirements and design of the rough opening is the responsibility of the architect or engineer. Window frame systems are not designed to support additional elements or components of the building wall system.

Specific accessories and construction details must address the various conditions that are critical for the proper design of a horizontal combination of windows (ribbon windows) and vertical combination (stacked windows) such as:

- Proper flashing
- Control joints to accommodate expansion and contraction
- Intermediate structural support
- Mullion reinforcing end anchorage
- Rough opening wall construction to accept loads transferred from window combination.

Definitions:

Combination	An assembly formed by two or more separate windows, window composites, or doors whose frames are mullied together using a combination joining mullion or reinforcing mullion.
Structural Mullion	A horizontal or vertical member with an added continuous mullion stiffener and joining two or more individual windows along the sides of the mullion stiffener.
Composite	A window consisting of two or more sash in one frame utilizing an integral mullion.
Integral Mullion	A horizontal or vertical member which is bounded at either end or both ends by a crossing frame member.



The following steps are provided as a guide to help the designer properly integrate Pella products and accessories in combination assemblies. Sample calculations based on these steps are later in this section.

1. Determine the overall size and configuration of the combination.

Page 6 shows the basic combination assembly types. Windows within the combination can be fixed or venting.

2. Determine the required wind load (design pressure).

The Design Pressure (DP) is the wind load pressure that the window assembly must withstand. The Design Pressure (DP) should be determined by the project engineer or architect but can also be provided by the local code official.

ASCE 7-5/ASCE 7-10, Minimum Design Loads for Buildings and Other Structures contains the generally accepted method for determining Design Pressure (DP) for components and cladding based on building size and shape, geographical location, topographical factors, building use and location on the building's surface.

3. Determine if the individual windows and/or doors within the assembly meet the required design pressure.

Each Pella window is rated to withstand a certain level of wind loading. The design pressure determined in step 2 should also be used to specify window performance. The Performance section of this manual provides more detailed information on the relationship between design pressure and the performance class and grade ratings used to specify window performance. See each product section to determine if each window or door can withstand the required design pressure.

4. Determine if the combination will be factory assembled or non-factory assembled.

Use the combination size tables found in this section to determine if the combination is available factory assembled. If it is not found in the size tables, it is not available from the factory. Also consider factors such as installation method, handling and accessibility to the opening. Conditions specific to the project may require that a combination be assembled in the opening.

5. Determine the requirement for spread or reinforcing mullions.

Placing windows in an assembly creates joints or mullions that may need reinforcing and/or flashing requirements. In order to ensure that a given combination will withstand the design pressure determined in step 2, use the mullion joint load tables later in this document. These tables are organized by joint type. Use the graphical representation of each joint type to determine which joint type(s) are contained within the combination. The reinforcing tables consider structural performance only. Performance class and grade ratings apply to single units only. See the Size and Performance Data page within each product section for more information.

Also consider the dead load when placing windows over doors.

6. Determine the appropriate reinforcing mullion.

The mullion reinforcing tables in this section are intended to aid in the selection of reinforcing members to help the assembly resist the forces placed upon it by wind loads and loads caused by other units within the combination. Page 12 provides instruction on how to use the tables. By entering the tables with the joint's mullion length and the widths of the adjacent units, choose any mullion reinforcing option at or below the coordinate given on the table. If spread mullions are desired for aesthetic reasons, use the tables to determine if the spread mullion is sufficient.

7. Determine actual rough opening size and window/door data.

This section contains recommendation pages for each assembly type. Use the recommendations in this section to determine rough opening clearance dimensions as well as if subsill is required. Add any applicable frame, accessory, and mullion dimensions to arrive at the overall opening dimensions.

The combination assembly design example on page 12 shows how these steps can be followed to design a combination assembly.



250 Series - Combinations

Composite Configurations

Composite units are AAMA/WDMA performance certified from R-PG20 to R-PG50 when glazed with the appropriate glass. Pella® 250 Series composites are engineered to meet the performance class and grade shown in the design data tables in each product section. Composites are available in window types and configurations shown below. See the product sections for complete details.

Composite Configurations

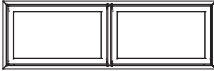
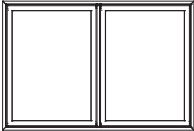
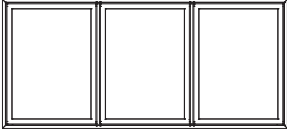
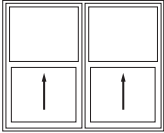
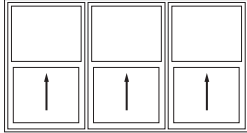
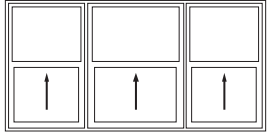
	2-Wide Composite with Integral Mullion	3-Wide Composite with Integral Mullion
Awning		
Casement		
Single- and Double-Hung		 



Typical Sealant Recommendations

Proper sealant placement is critical to window or door performance. See typical exterior and interior perimeter sealant details below.

Interior and Exterior Sealant Placement Detail

TYPICAL EXTERIOR PERIMETER SEALANT DETAIL

TYPICAL INTERIOR PERIMETER SEALANT DETAIL

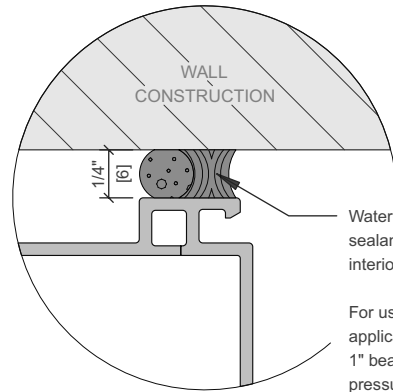
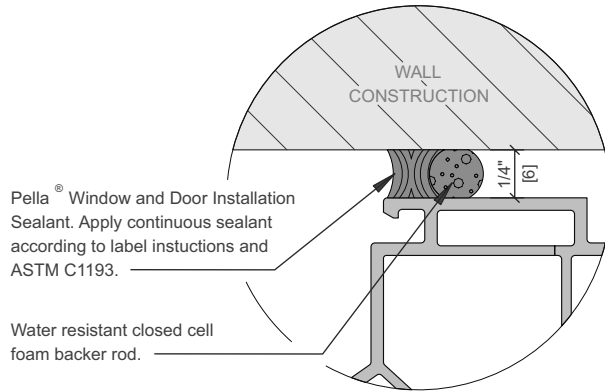

When applying siding, brick veneer or other exterior finish material, leave adequate space between the unit frame and the exterior finish material for backer rod and sealant.

Note: The sealant details shown are standard recommendations from the sealant industry. Contact your sealant supplier for recommendations and instruction for this or any other application.

Single Unit Opening Recommendations

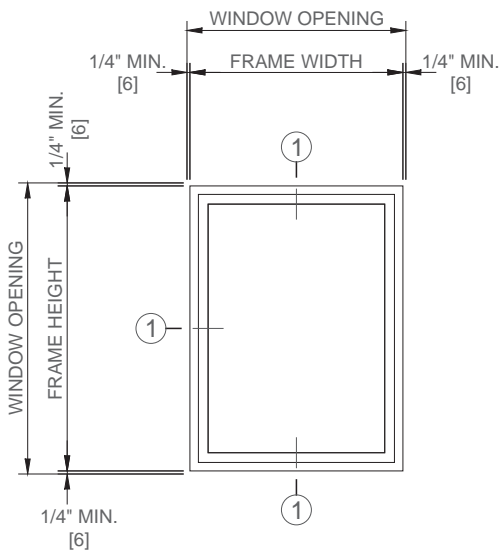

① To determine window openings for typical installations, add 1/2" to frame width and 1/2" to frame height. For large size units, and/or in masonry construction, the need for additional rough opening clearances should be reviewed.

Typical installation details and accessories are shown in the Installation Details section.

Determine if unit performance meets design requirements. Unit performance limitations are in each product section.

See typical exterior and interior perimeter sealant details above. Proper sealant placement is critical to window performance.



1. 1/2" clearance is recommended at each jamb in masonry construction or large combinations.
2. Window combinations may require reinforcing mullions, reference mullion load charts later in this section.
3. Pella® 250 Series windows should not be directly mullied to doors at jambs. Field framing must be used between all doors and Pella 250 Series windows.

Proper sealant placement is critical to window performance.

Typical Window Combinations

Two-Way

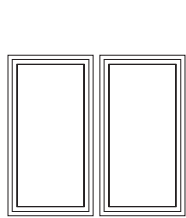

Horizontal

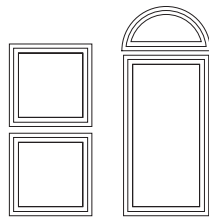

Vertical

Three-Way

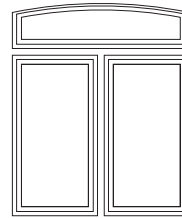
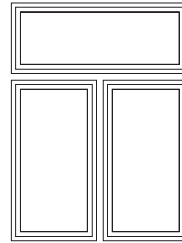
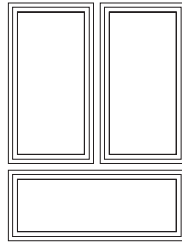

Four-Way

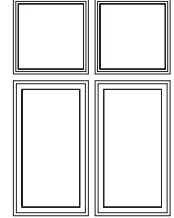



250 Series - Combinations

Two-Way Vertical Joint Recommendations and Parameters

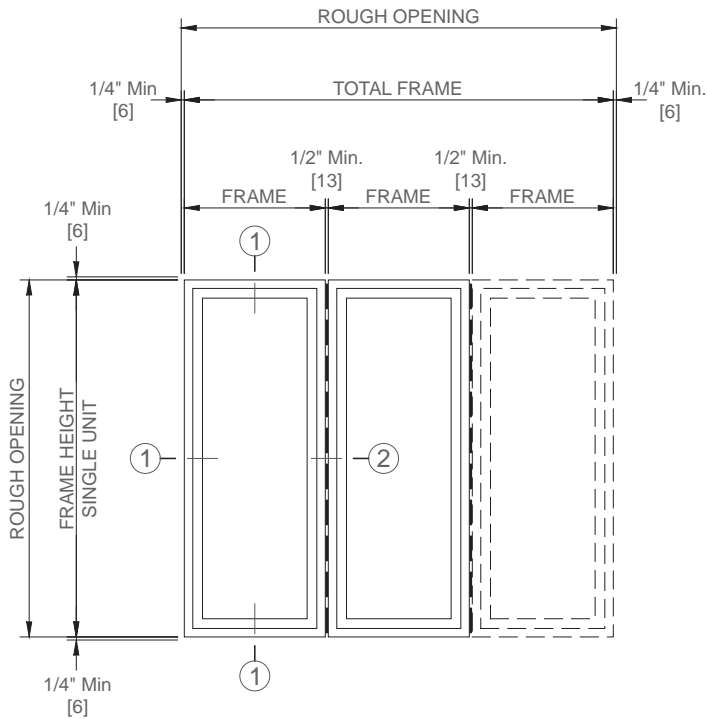

These recommendations apply to a typical horizontal combination of any vent or fixed unit. Each unit may be a single or composite unit.

See the instructions provided with the mullion kit for complete mullion assembly information.

Refer to single-unit opening recommendations in addition to the following:

- ① Minimum 1/4" clearance on smaller openings. Minimum 1/2" clearance is recommended at each jamb for openings with three or more windows.
- ② A reinforcing mullion might be required. See the mullion parameters below or the mullion load charts later in this document.

Proper sealant placement is critical to window performance. See sealant details on page 5.

Vinyl Combinations Structural Mullion Parameters

1/2" Structural Mullion

Mullion length limits: 108"

Any window greater than 25 sq ft may not be mullioned horizontally above a 1-wide product greater than 48" Frame Width

1/2" mullion cannot be used with 5/8" Flange Frame

Any window greater than 50 Sq. ft. cannot go over a two-wide unit.

1" Structural Mullion

Mullioned product combinations cannot exceed 72 Sq ft.

Mullion length limits: 108"

Any window greater than 25 sq ft may not be mullioned horizontally above a fixed 1-wide product greater than 72" Frame Width

1" structural mullion can not be used with 5/8" flange frames or Double-Wall Flush Flange

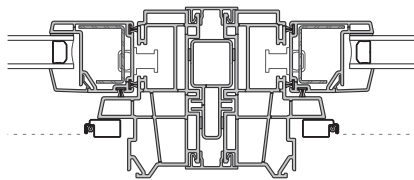

1/2" Joining Mullion

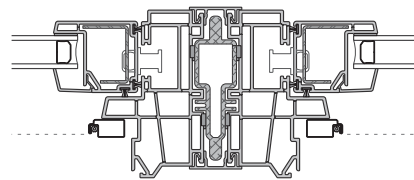

1/2" Structural Mullion

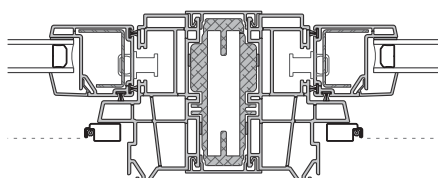

1" Structural Mullion

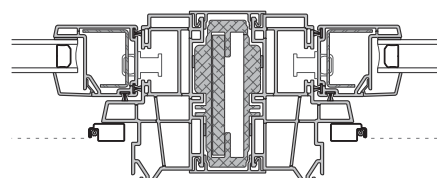

1" Structural Mullion with Reinforcement(s)



Two-Way Horizontal Joint Recommendations and Parameters

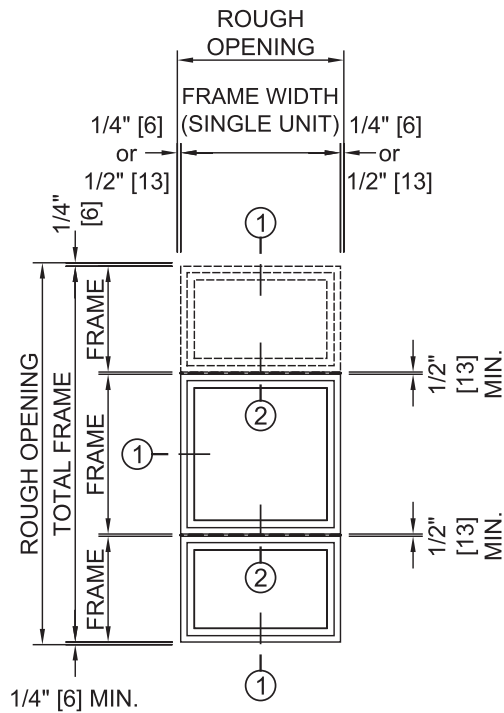

These recommendations apply to typical vertical stacking of vent or fixed units of the same width to a maximum height of 8' 11-1/2" without intermediate support. Each unit may be a single or composite unit.

See the instructions provided with the mullion kit for complete mullion assembly information.

Refer to single-unit opening recommendations in addition to the following:

- ① Minimum 1/4" clearance on small openings. 1/2" clearance is recommended at opening with three (3) windows or in masonry openings.
- ② A reinforcing mullion might be required. See the mullion parameters below or the mullion load charts later in this document.

Proper sealant placement is critical to window performance. See sealant details on page 5.



Three-Way Window Recommendations and Parameters

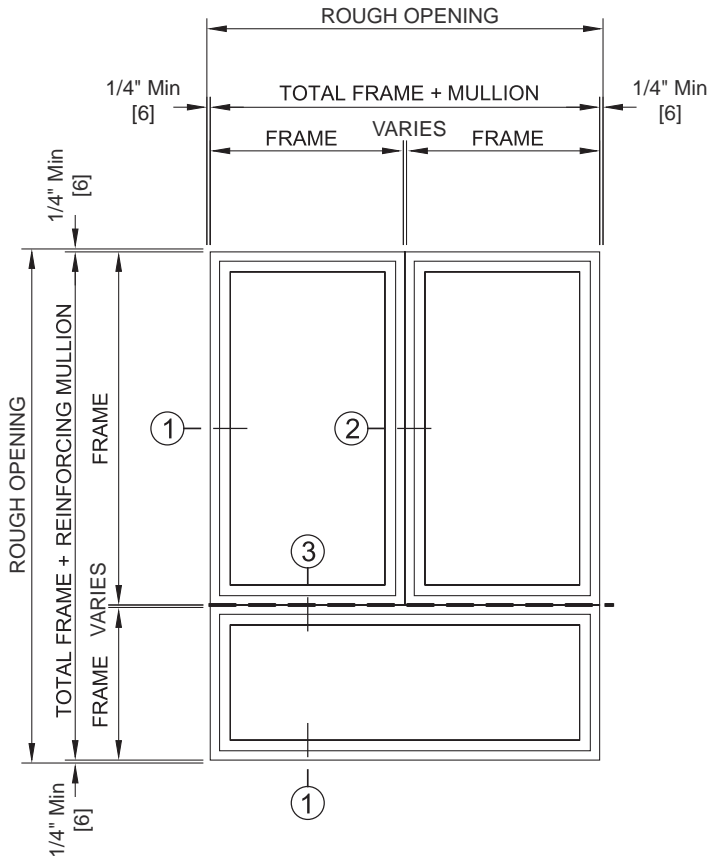

These recommendations apply to a typical grouping of any two vent or fixed units over one fixed unit that forms a three-way mullion intersection.

Refer to single-unit opening recommendations in addition to the following:

- ① Minimum of 1/4" clearance at the head, jamb and sill of small openings. 1/2" clearance is recommended on larger openings and masonry openings.
- ② 1/2" combination (joining) mullion. A minimum of 1/2" is required. See mullion load chart on later pages.
- ③ Structural mullion is required. See mullion load chart on later pages.

Proper sealant placement is critical to window performance. See sealant details on page 5.



Four-Way Window Recommendations and Parameters

These recommendations apply to a typical grouping of any combination of window units that form a four-way mullion intersection.

Refer to single-unit opening recommendations in addition to the following:

- ① Minimum of 1/4" clearance at the head, jamb and sill of small openings. 1/2" clearance is recommended on larger openings and masonry openings.
- ② 1/2" minimum structural mullion is required. See mullion load chart on later pages.
- ③ All four-way mullion intersections require structural mullion in one direction (either vertically or horizontally, see mullion load chart on later pages).

Proper sealant placement is critical to window performance. See sealant details on page 5.

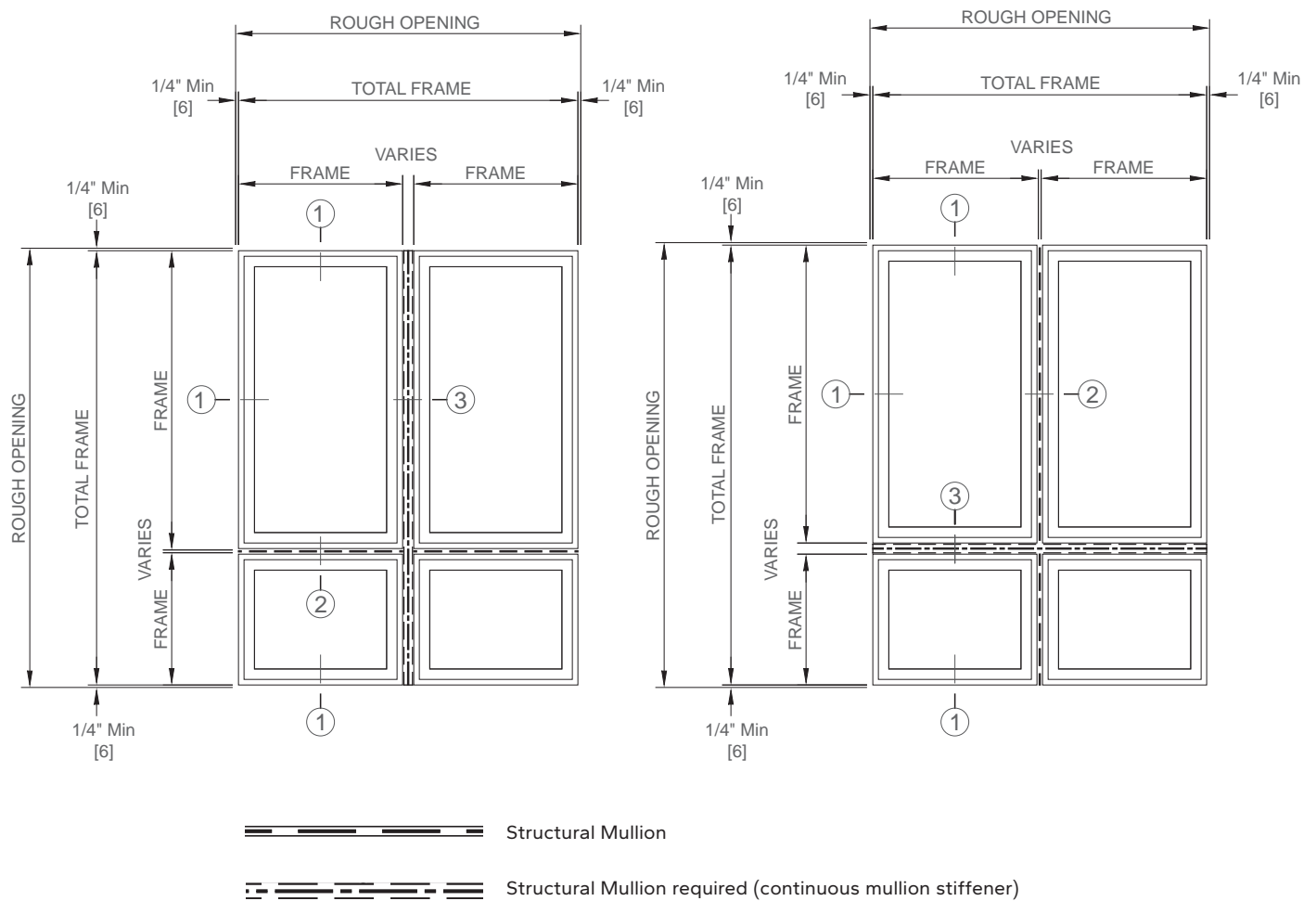



250 Series - Combinations

Mullion End Anchor Capacity

To Calculate End Load At Mullion Reinforcement:

$$\text{Load per end} = [(A + B) \times L \times P] / 2$$

A = Half the distance in feet from the mullion for which the loading is being figured to the next structural member to the left.

B = Half the distance in feet from the mullion for which the loading is being figured to the next structural member to the right.

P = Design wind load pressure required for the building project in pounds per square foot.

L = Mullion length in feet.

Anchor	Qty	Screw Type	Embedment		Capacity (lbs)
			Material	Depth (in)	
* Fin End Anchor	(6)	No. 10 Pan Head Wood Screw	Wood	1-1/2	900
	(4)	3/16" Flat or Pan Head Concrete Anchor	Concrete	1-3/4	800
** Screw Thru Frame/Clip	(4)	3/16" Flat or Pan Head Masonry Anchor	Masonry	1	800
	(6)	No 10 Flat or Pan Head Wood Screw	Wood	1-1/2	800
	(6)	No. 10 Flat or Pan Head Self drilling screws	Steel	fully penetrate substrate with 3 threads protruding internally	1000

(A) - MULLION

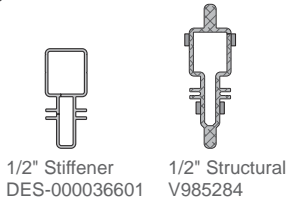

(B) - MULLION END ANCHORS

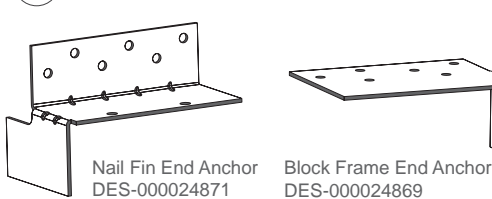

(C) - MULLION TRUSS PLATES

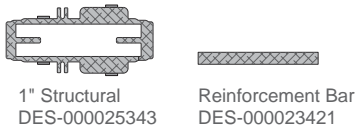
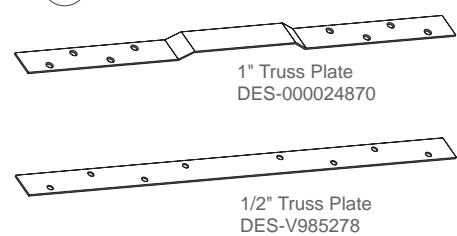

(E) - HEAD DRIP FIN

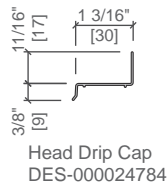

(F) - MULLION SPLICES

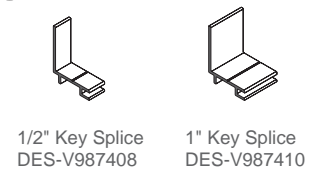

(D) - MULLION COVERS

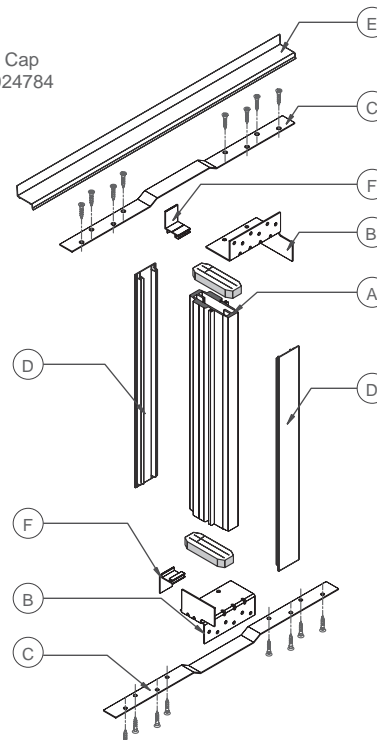
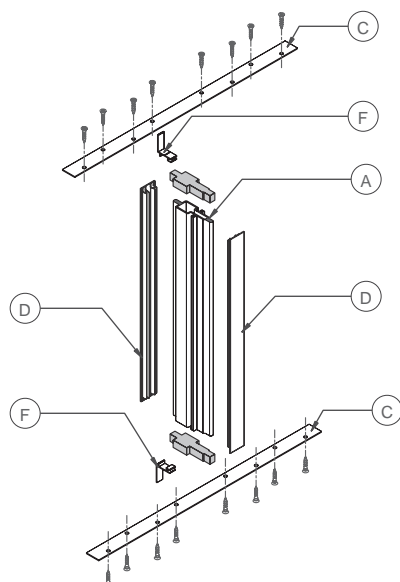
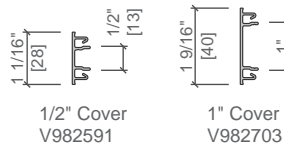



The following sample calculations are based on steps 1-8 on page 3.

1. Determine the overall size of the configuration of the combination or composite.

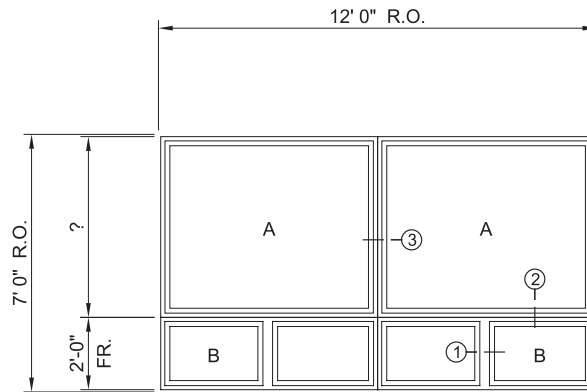

Product: Fixed Window

- ① Integral Mullion
- ② Mullion type to be determined
- ③ Mullion type to be determined

2. Determine the required windload (design pressure).

Project description:

Location: Pella, IA
 Based on in ASCE 7-02, Minimum Design Loads for Buildings and Other Structures
 Wind speed = 90 mph, Exposure B
 Design Pressure: 20 psf

3. Determine individual window size and performance (nominal sizing).

Individual Window Performance: Unit A

Project design pressure: 20 psf
 Required window/door performance class and grade rating: R20
 Applicable Product – Pella 250 Series Fixed Window
 Individual window size and performance:
 6-0/5-0 – Performance Class and Grade = CW40
 Therefore selected windows meet design pressure requirements.

Individual Window Performance: Unit B

Project design pressure: 20 psf
 Required window/door performance class and grade rating: R20
 Applicable Product - Pella 250 Series 2-Wide Fixed Window Composite with Integral Mullion:
 3-0/2-0 - 2 - Performance Class and Grade = LC25
 (see fixed window product section)

① = Integral Mullion
 Therefore selected windows meet design pressure requirements.

4. Determine glazing performance. Verify Glass Design thickness in performance charts.

5. Determine if the combination will be factory assembled or non-factory assembled. For this example, portions of the window assembly are factory assembled and some are non-factory assembled.

6. Determine mullion types and reinforcement requirements: Windload (lateral loading) YES if yes, joint type: Joint ② = two-way joint Joint ③ = four-way joint Dead Load (above doors and awning) Not Applicable.

Continued on next page



7. Determine the appropriate mullion:

(See pages 7 through 10 in this section for notes and instructions)

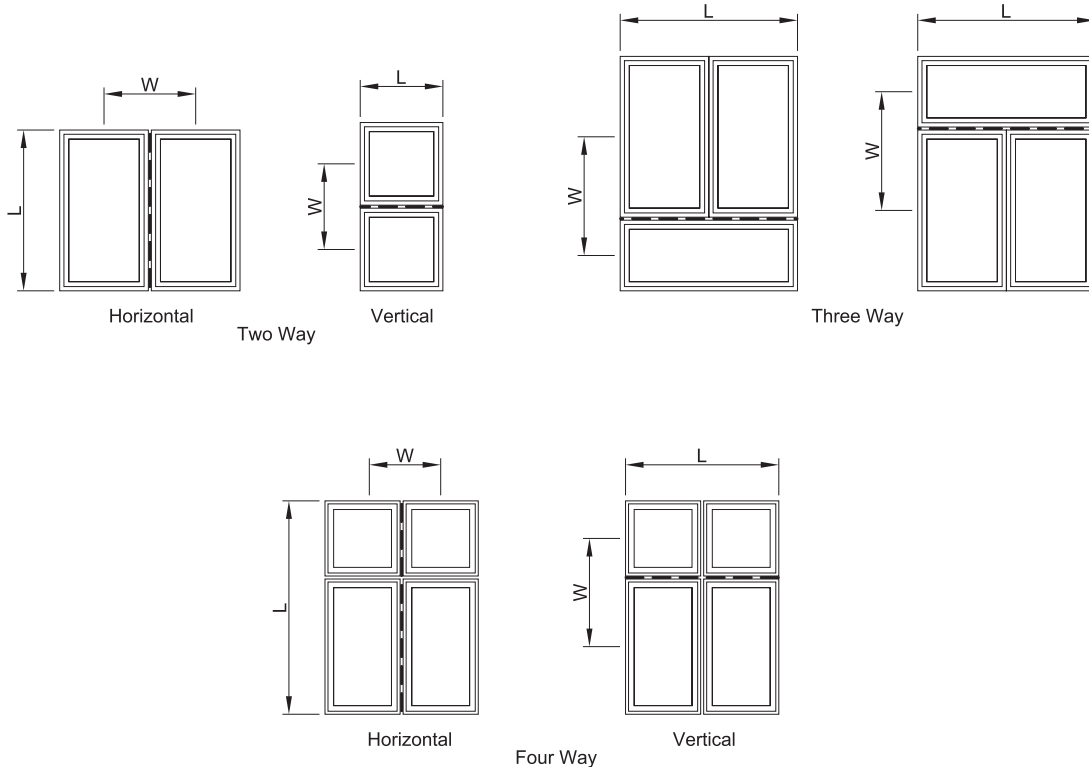

Determine structural mullion for joint ② (horizontal mullion) = Two way

- A. Determine L = Mullion length (in)
- B. Determine W = Windload width (in)
 - a. 1/2 the distance from the mullion to the member above = 30"
 - b. 1/2 the distance from the mullion to the member below = 12"
- C. Determine minimum structural mullion required

- Step 1 Enter the graph at the point of the mullion length (L).
- Step 2 Move to the loading width (W).
- Step 3 Move right to the column with the design pressure.

Joint ②

75"

42"

Use 75"
Use 42"
Use 20 psf

		Maximum Allowable Design Pressure (psf)										
		L (in)	W (in)	20	25	30	35	40	45	50	55	60
		75	24	B	B	B	B	C	C	C	C	C
		75	30	B	B	C	C	C	C	C	D	E
		75	36	B	C	C	C	C	D	E	E	E
1	2	75	48	C	C	C	D	E	E	E	F	H
		75	54	C	C	D	E	E	E	H	H	H
		75	60	C	C	E	E	E	H	H	H	H
		75	66	C	D	E	E	F	H	H	H	H
		75	72	C	E	E	F	H	H	H	H	J

See actual mullion load charts in this section for details.

Reinforcing mullion results:

Joint ② : Minimum structural mullion C = 1/2" Structural Mullion. We will use D = 2- 2x4 wood studs for this example.

Continued on next page



250 Series - Combinations

Sample Calculations

Determine structural mullion for joint ③ = Four-Way Joint

- A. Determine L = Mullion length (in) Rough Opening Width
- B. Determine W = Windload width (in)
 - a. 1/2 the distance from the mullion to the left member = 36"
 - b. 1/2 the distance from the mullion to the right member = 36"
- C. Determine minimum structural mullion required

Step 1 Enter the graph at the point of the mullion length (L).

Step 2 Move to the loading width (W).

Step 3 Move right to the column with the design pressure.

Joint ③

84"

72"

Use 84"

Use 72"

Use 20 psf

Minimum structural mullion:

E = 1" Structural Mullion. We will use ② - 2x6 wood stud reinforcements for this example.

See actual mullion load charts in this section for details.

		Maximum Allowable Design Pressure (psf)									
L (in)	W (in)	20	25	30	35	40	45	50	55	60	
84	24	B	C	C	C	C	E	E	E	E	
84	30	C	C	C	D	E	E	F	F	H	
84	36	C	C	E	E	E	F	H	H	H	
84	48	C	E	E	F	H	H	H	H	J	
84	54	E	E	F	H	H	H	H	J	J	
84	60	E	F	H	H	H	H	J	J	J	
84	66	E	F	H	H	H	J	J	J	L	
84	72	E	H	H	H	J	J	J	L	M	

8. Determine actual rough opening size and window data:

Rough Opening Width: Example:

Rough Opening	144"
Jamb Clearance (1/4" x 2)	- 1/2"
Number of vertical mullions x (mullion width + clearance when required) (1x3" + (1/4"x)2)	-3-1/2"
Total Window width	140"
Window width ÷ number of windows	70"

Rough Opening Height: Example:

Rough Opening	84"
Sill and head clearance (1/4" x 2)	- 1/2"
Number of horizontal mullions x (mullion width + clearance when required) (1x3" + (1/4"x)2)	-3-1/2"
Total unit height (Use 4'8" frame height over 2'0" frame height units)	80"

Final Layout and Detail:

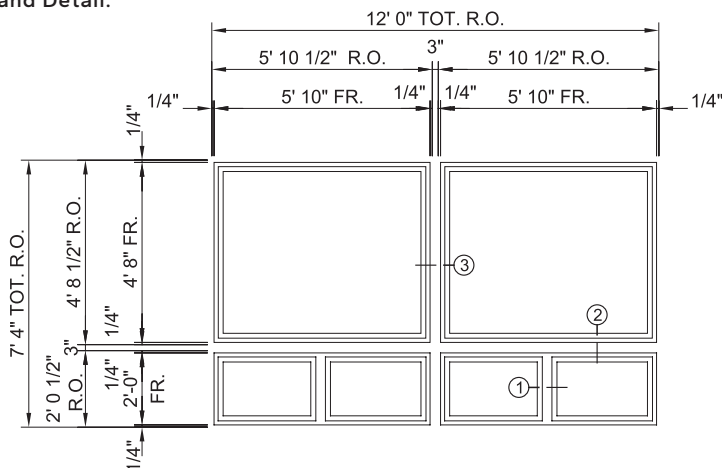

- ① Integral Mullion
- ② 2 - 2" x 4" Nominal Wood Reinforcing Mullion
- ③ 2 - 2" x 6" Nominal Wood Reinforcing Mullion



250 Series - Combinations

Non-Factory Assembled - Window Mullied to Window

Maximum Allowable Design Pressure (psf)								
L (in)	W (in)	20	25	30	35	40	45	50
36	66	A	B	B	B	B	B	B
36	72	A	B	B	B	B	B	C
36	80	A	B	B	B	B	C	C
36	84	A	B	B	B	B	C	C
36	96	A	B	B	B	C	C	C
36	108	A	B	B	C	C	C	C
48	36	A	B	B	B	B	B	B
48	42	A	B	B	B	B	B	C
48	48	A	B	B	B	C	C	C
48	54	A	B	B	B	C	C	C
48	60	B	B	B	C	C	C	C
48	66	B	B	C	C	C	C	C
48	72	B	B	C	C	C	C	C
48	80	B	C	C	C	C	C	C
48	84	B	C	C	C	C	C	C
48	96	C	C	C	C	C	E	E
48	108	C	C	C	C	E	E	E
53	24	A	B	B	B	B	B	B
53	30	A	B	B	B	B	B	B
53	36	A	B	B	B	B	C	C
53	42	B	B	B	B	C	C	C
53	48	B	B	B	C	C	C	C
53	54	B	B	C	C	C	C	C
53	60	B	B	C	C	C	C	C
53	66	B	C	C	C	C	C	E
53	72	B	C	C	C	C	E	E
53	80	C	C	C	C	E	E	E
53	84	C	C	C	C	E	E	E
53	96	C	C	C	E	E	E	E
53	108	C	C	E	E	E	E	E
60	24	B	B	B	B	B	B	B
60	30	B	B	B	B	B	C	C
60	36	B	B	B	C	C	C	C
60	42	B	B	C	C	C	C	C
60	48	B	B	C	C	C	C	D
60	54	B	C	C	C	C	D	E
60	60	B	C	C	C	D	E	E
60	66	C	C	C	D	E	E	E
60	72	C	C	C	E	E	E	E
60	80	C	C	D	E	E	E	E
60	84	C	C	E	E	E	E	E
60	96	C	D	E	E	E	E	E
60	108	C	E	E	E	E	E	G
65	24	B	B	B	B	B	C	C
65	30	B	B	B	C	C	C	C
65	36	B	B	C	C	C	C	D
65	42	B	C	C	C	C	D	E
65	48	B	C	C	C	D	E	E
65	54	C	C	C	D	E	E	E
65	60	C	C	D	E	E	E	E
65	66	C	C	D	E	E	E	E
65	72	C	D	E	E	E	E	E
65	80	C	D	E	E	E	E	G
65	84	C	E	E	E	E	E	G
65	96	D	E	E	E	E	G	G
65	108	E	E	E	E	G	G	H
70	24	B	B	B	B	C	C	C
70	31	B	B	C	C	C	D	D
70	36	B	C	C	C	D	D	E
70	42	B	C	C	D	D	E	E
70	48	C	C	D	D	E	E	E
70	54	C	C	D	E	E	E	E
70	60	C	D	E	E	E	E	E
70	66	C	D	E	E	E	E	G
70	72	D	E	E	E	E	G	G
70	80	D	E	E	E	G	G	G
70	84	D	E	E	E	G	G	H
70	96	E	E	E	G	G	H	H
70	108	E	E	G	G	H	H	K

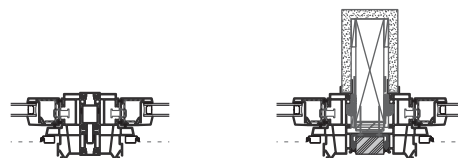

A - 1/2" Joining Mullion

F - 2 x 6 Nominal Wood

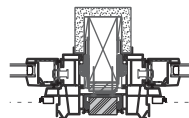

B - 2 x 4 Nominal Wood

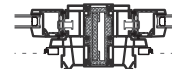

G - 1" Structural Mullion W/ 1 Reinforcement

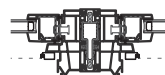

C - 1/2" Structural Mullion



H - 1" Structural Mullion W/ 2 Reinforcements

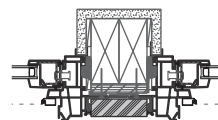

D - (2)- 2 x 4 Nominal Wood

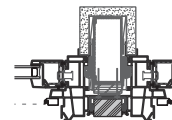

I - 18 ga 1-3/8" x 3-5/8" Steel Stud

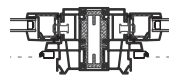

E - 1" Structural Mullion

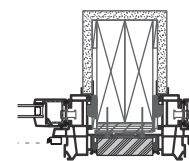

J - (2)- 2 x 6 Nominal Wood

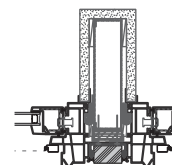

K - 20 ga 1-3/8" x 6" Steel Stud

All reinforcing mullions must be properly secured at ends. Wall framing around window opening must be adequate to withstand wind loads transferred from window composite and reinforcing mullions.

Do not use these accessories or mullions for structural vertical loading. Reinforcing mullions are for wind loading only.

If mullion length or load factor exceed chart values, please contact your local Pella sales representative.

Design charts are not valid for locations where impact forces from airborne debris must be considered.

To determine allowable mullion wind load for $L/175 \leq .75$ " deflection go to page 2 for instructions.

Continued on next page



250 Series - Combinations

Non-Factory Assembled - Window Mullered to Window

Maximum Allowable Design Pressure (psf)								
L (in)	W (in)	20	25	30	35	40	45	50
75	24	B	B	B	C	C	C	D
75	30	B	B	C	C	D	D	D
75	36	B	C	C	D	D	E	E
75	42	C	C	D	D	E	E	E
75	48	C	D	D	E	E	E	E
75	54	C	D	E	E	E	E	G
75	60	D	D	E	E	E	G	G
75	66	D	E	E	E	G	G	H
75	72	D	E	E	E	G	G	H
75	80	E	E	E	G	G	H	K
75	84	E	E	E	G	H	H	K
75	96	E	E	G	H	H	K	K
75	108	E	G	G	H	K	K	K
84	24	B	C	C	D	D	D	E
84	30	C	C	D	D	E	E	E
84	36	C	D	D	E	E	E	E
84	42	D	D	E	E	E	G	G
84	48	D	E	E	E	G	G	H
84	54	D	E	E	G	G	H	H
84	60	E	E	E	G	H	H	J
84	66	E	E	G	G	H	I	K
84	72	E	E	G	H	I	K	K
84	80	E	G	H	H	K	K	K
84	84	E	G	H	I	K	K	K
84	96	G	H	I	K	K	K	**
84	108	G	H	K	K	K	**	**
96	24	C	D	D	E	E	E	E
96	30	D	D	E	E	E	G	G
96	36	D	E	E	G	G	H	H
96	42	E	E	G	G	H	I	I
96	48	E	E	G	H	I	I	K
96	54	E	G	H	I	I	K	K
96	60	E	G	H	I	K	K	K
96	66	G	H	I	J	K	K	K
96	72	G	H	I	K	K	K	**
96	80	H	I	K	K	K	**	**
96	84	H	I	K	K	K	**	**
96	96	I	K	K	K	**	**	**
96	108	I	K	K	**	**	**	**
108	24	D	E	E	E	G	G	H
108	30	E	E	F	G	H	I	I
108	36	E	F	G	H	I	I	J
108	42	E	G	H	I	I	K	K
108	48	G	H	I	I	K	K	K
108	54	G	I	I	K	K	K	K
108	60	H	I	J	K	K	K	**
108	66	H	I	K	K	K	**	**
108	72	I	J	K	K	**	**	**
108	80	I	K	K	K	**	**	**
108	84	I	K	K	**	**	**	**
108	96	K	K	**	**	**	**	**
108	108	K	K	**	**	**	**	**
124	24	F	F	I	I	I	I	J
124	30	F	I	I	I	J	J	K
124	36	I	I	I	J	K	K	K
124	42	I	I	J	K	K	K	K
124	48	I	J	K	K	K	**	**
124	54	I	J	K	K	**	**	**
124	60	J	K	K	K	**	**	**
124	66	J	K	K	**	**	**	**
124	72	K	K	**	**	**	**	**
124	80	K	K	**	**	**	**	**
124	84	K	K	**	**	**	**	**

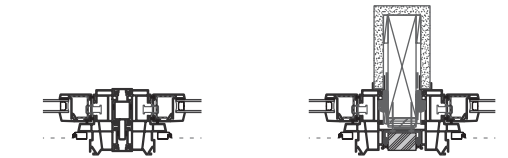

A - 1/2" Joining Mullion

F - 2 x 6 Nominal Wood

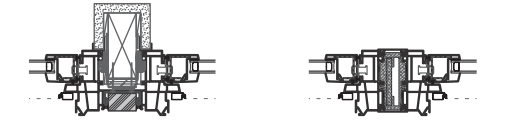

B - 2 x 4 Nominal Wood

G - 1" Structural Mullion W/ 1 Reinforcement

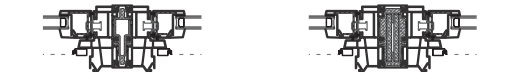

C - 1/2" Structural Mullion

H - 1" Structural Mullion W/ 2 Reinforcements

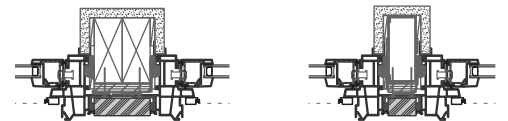

D - (2)- 2 x 4 Nominal Wood

I - 18 ga 1-3/8" x 3-5/8" Steel Stud

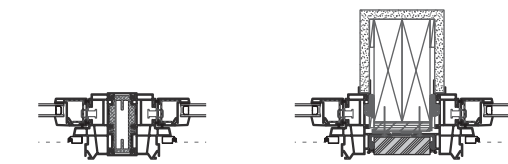

E - 1" Structural Mullion

J - (2)- 2 x 6 Nominal Wood



K - 20 ga 1-3/8" x 6" Steel Stud

All reinforcing mullions must be properly secured at ends. Wall framing around window opening must be adequate to withstand wind loads transferred from window composite and reinforcing mullions.

Do not use these accessories or mullions for structural vertical loading. Reinforcing mullions are for wind loading only.

If mullion length or load factor exceed chart values, please contact your local Pella sales representative.

Design charts are not valid for locations where impact forces from airborne debris must be considered.

To determine allowable mullion wind load for $L/175 \leq .75$ " deflection go to page 2 for instructions.