





2-PANEL (OX/XO) KNOCK-DOWN SLIDING DOOR ASSEMBLY

TOOLS REQUIRED:

- Screw Gun with a Phillips Drive bit 
- Sealant Gun 
- Mallet 
- Quick Grip Clamp 

REMEMBER TO USE APPROPRIATE PERSONAL PROTECTIVE EQUIPMENT

Lay parts on a flat hard surface with exterior cladding side up. Pella recommends keeping the panel and the frame parts on the cardboard to protect the interior surface during the assembly process. Frame parts have plastic spacers installed which help in panel alignment.

The step numbers of the following instruction correspond to the screw package numbers on the skin card and the number labels on the frame parts. Screw packs may include extra screws.

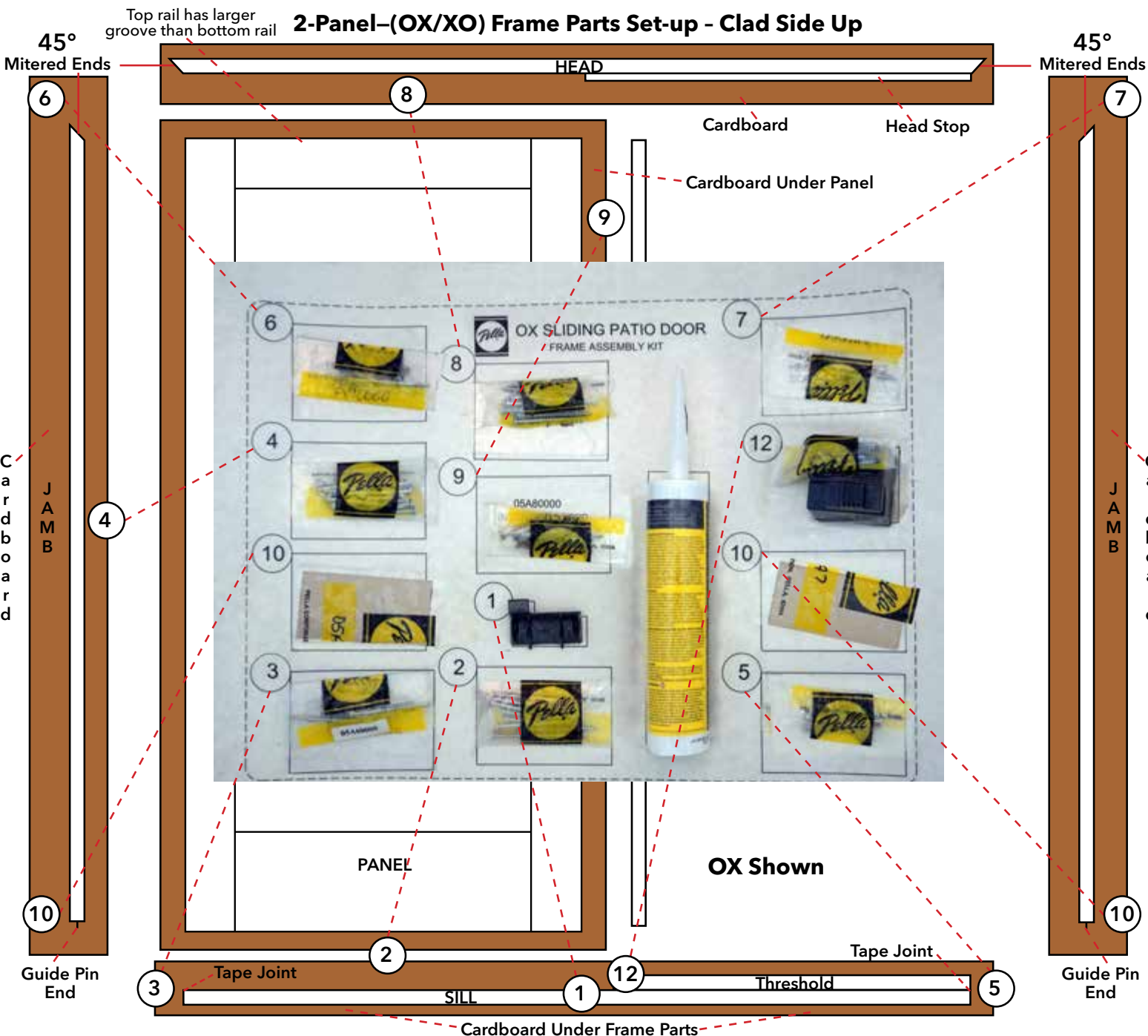

Frame numbered labels match the hardware item number and assembly step number. Start with step ①, Frame label ① and hardware item ①.

1

SILL ATTACHMENT: Sill dam - align the two tabs of hardware item ① with the two middle holes in the sill extrusion at label ① location. Rotate the sill dam down and snap onto the sill. The sill dam must be installed before the sill is attached to the bottom of the panel because the sill dam is held in place by the bottom edge of the panel cladding.

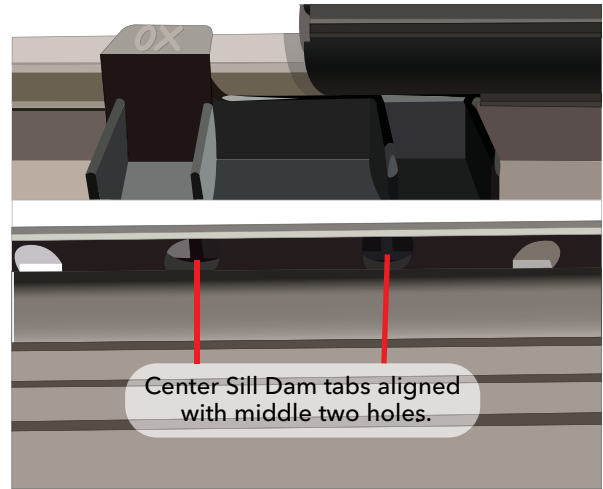
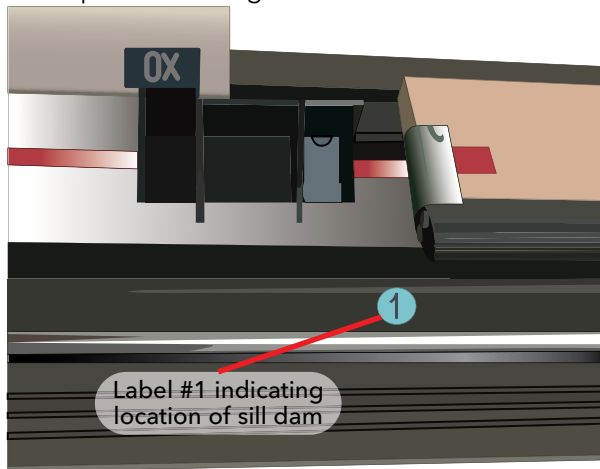

Remove (5) adhesive liners from the sill. (1 on each end of the sill; 1 on each end of the threshold; 1 across the length of the sill.)

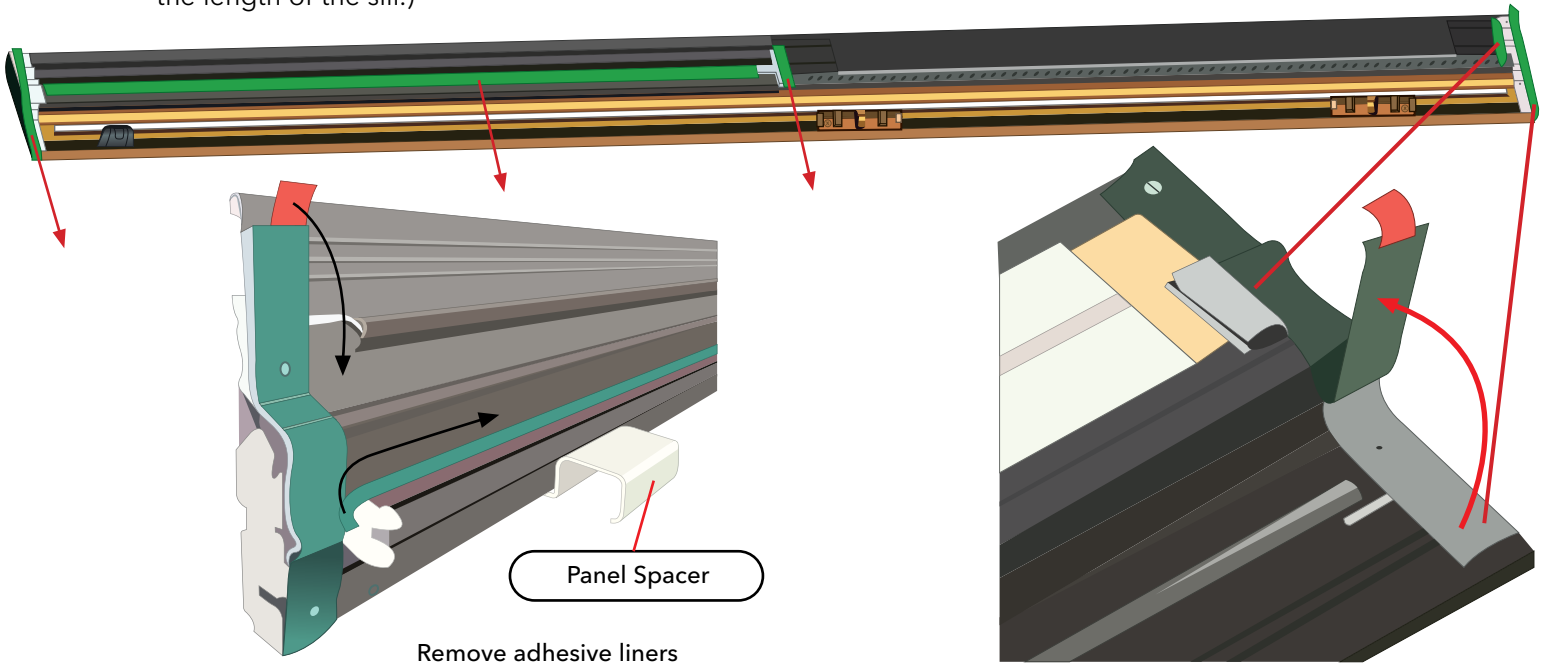

Remove two panel spacers from the lock jamb or use two of the loose panels spacers found in the Head & Sill Package and place under the bottom end of the panel.

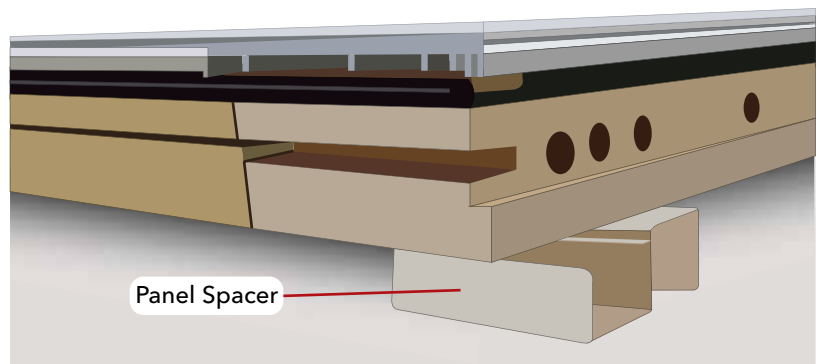

Bottom of panel at sill end has smaller rail groove.

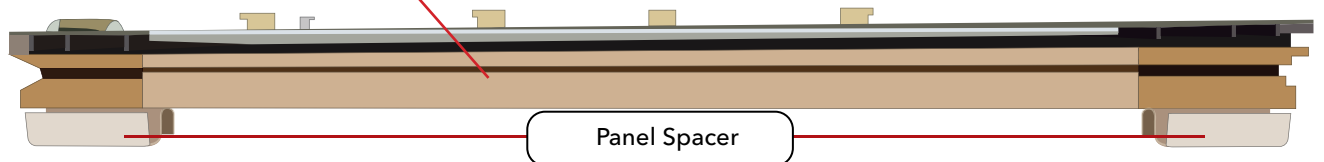

2

FIXED PANEL TO SILL ASSEMBLY: Place a bead of sealant in the groove across the length of the panel bottom.

Note: Sealant must reach edge of wood on both ends.

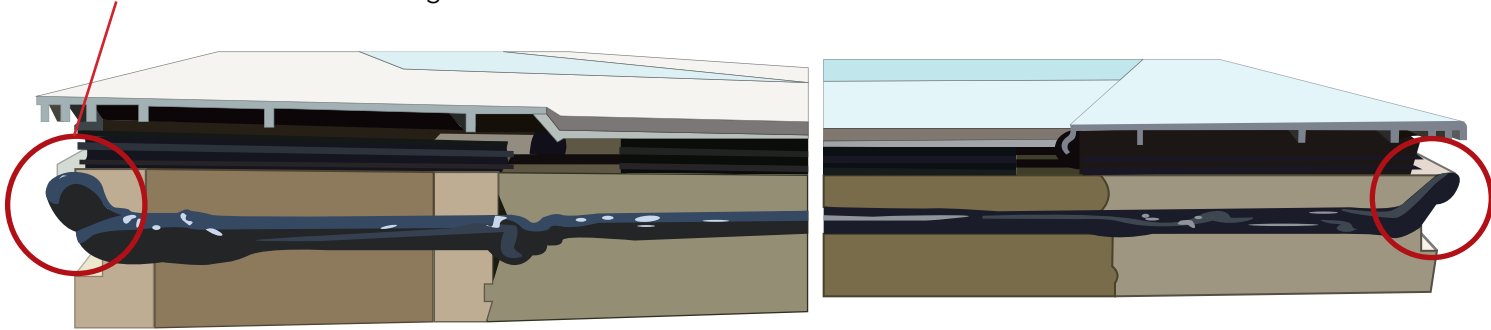

Position panel corner in the threshold/sill corner first.

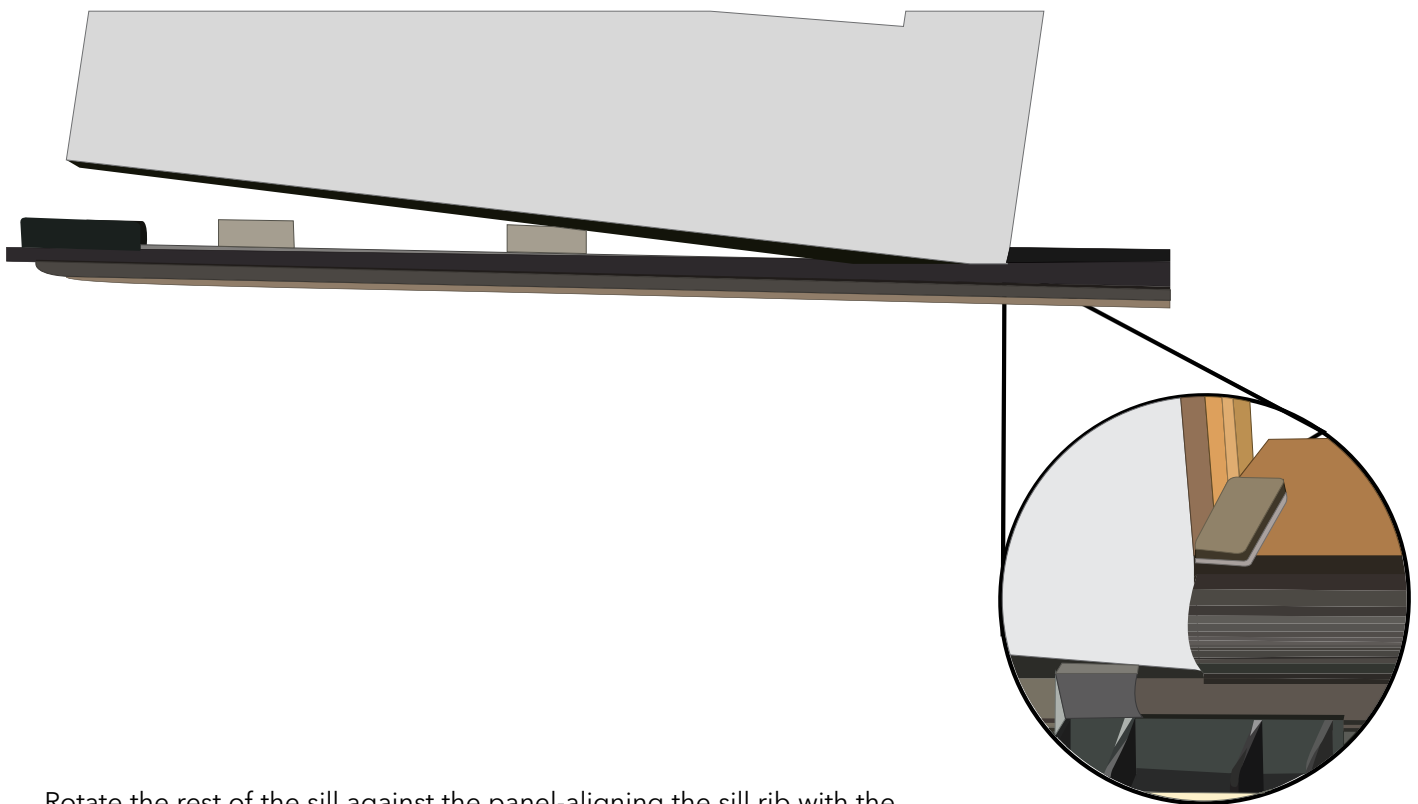

Rotate the rest of the sill against the panel-aligning the sill rib with the groove in the bottom of the panel where sealant was placed.

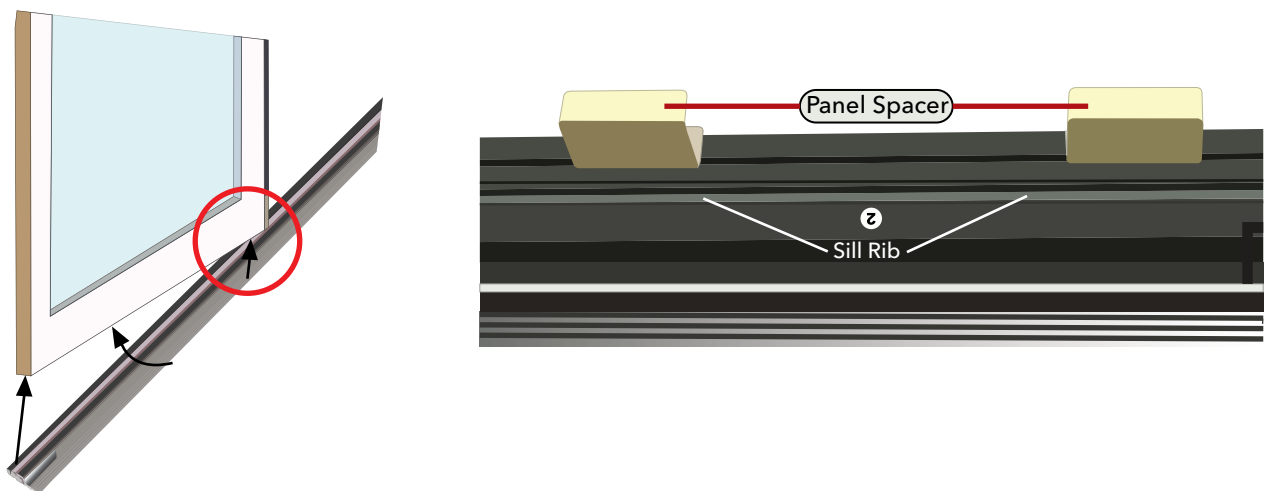

2
Continued

Align the sill block on the end of the sill to the slot on the panel edge and push the sill against the bottom of the panel.

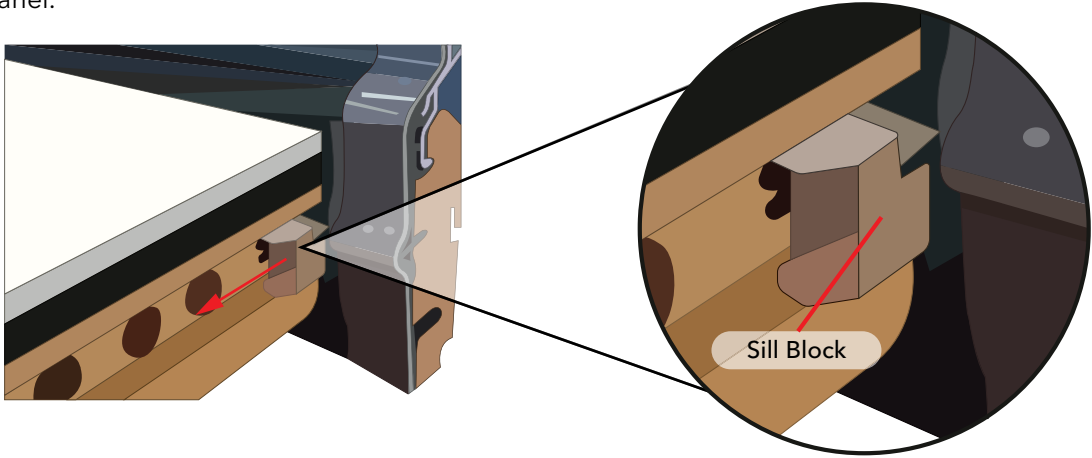

Install screws into the pre-drilled holes.

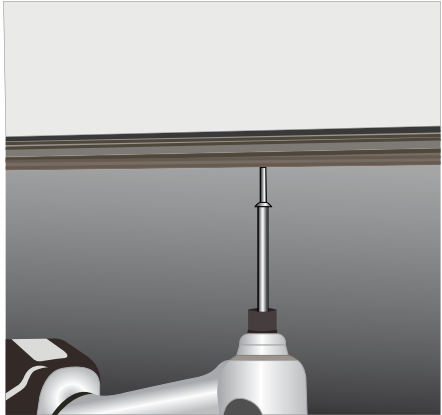
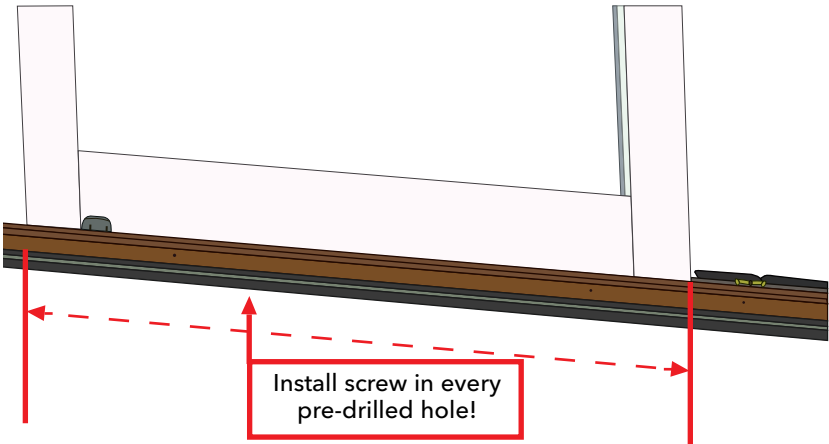

After screws are installed, remove panel spacers from the sill end of the panel and move to the head end of the panel.

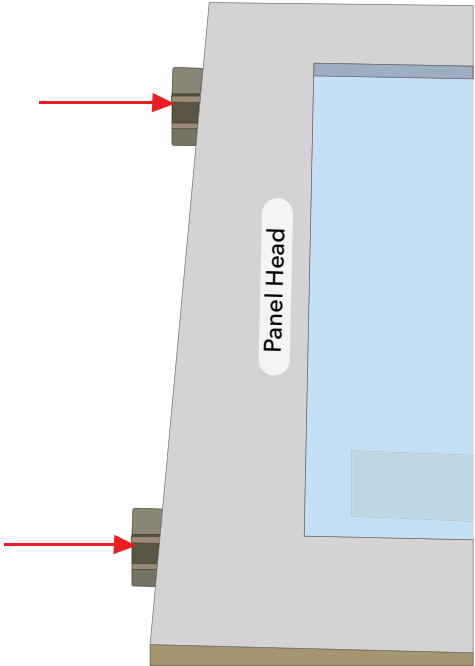
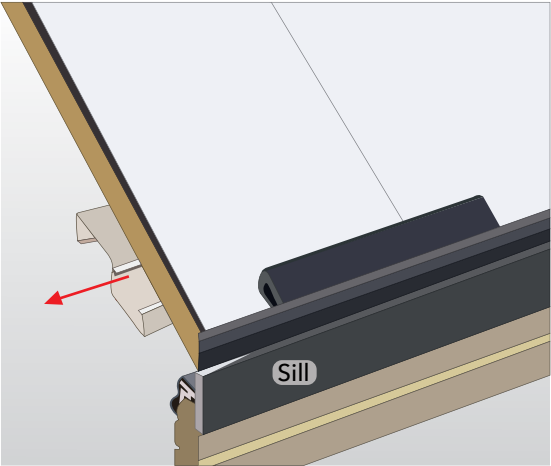

3

FIXED JAMB TO SILL: Position fixed jamb against the panel, align the jamb guide pin with the sill guide pin hole.

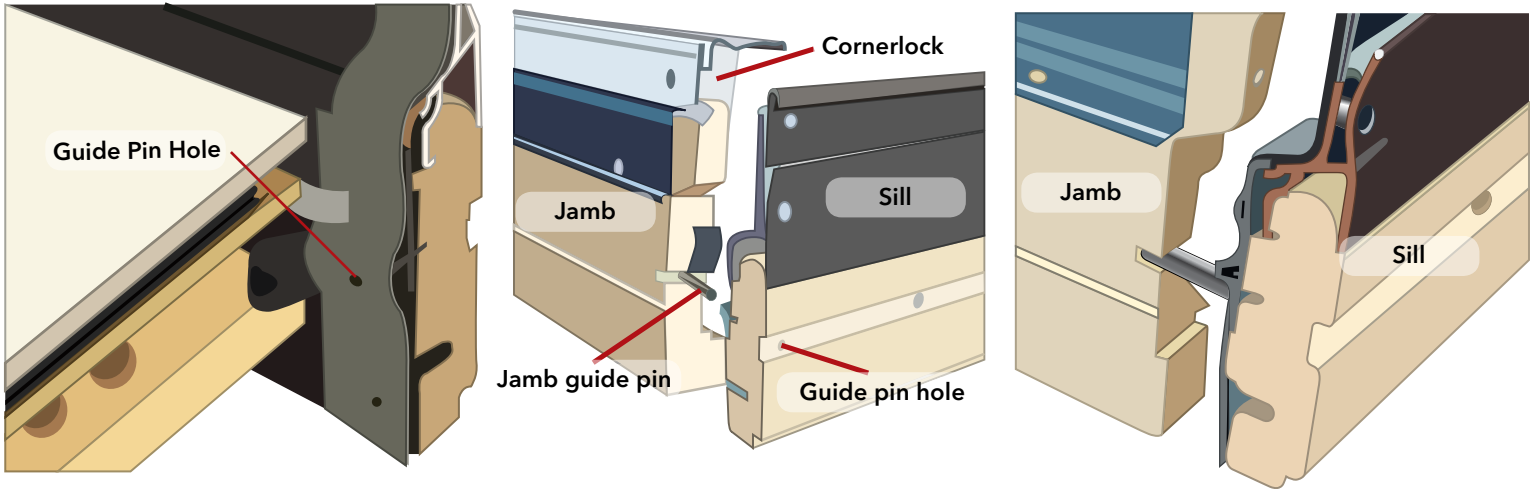

TIP: Keep the top end of the jamb partially away from the panel to facilitate the guide pin going into the sill guide hole. If needed, use a mallet to fully seat the jamb guide pin into the sill guide pin hole and to press the jamb against the sill.

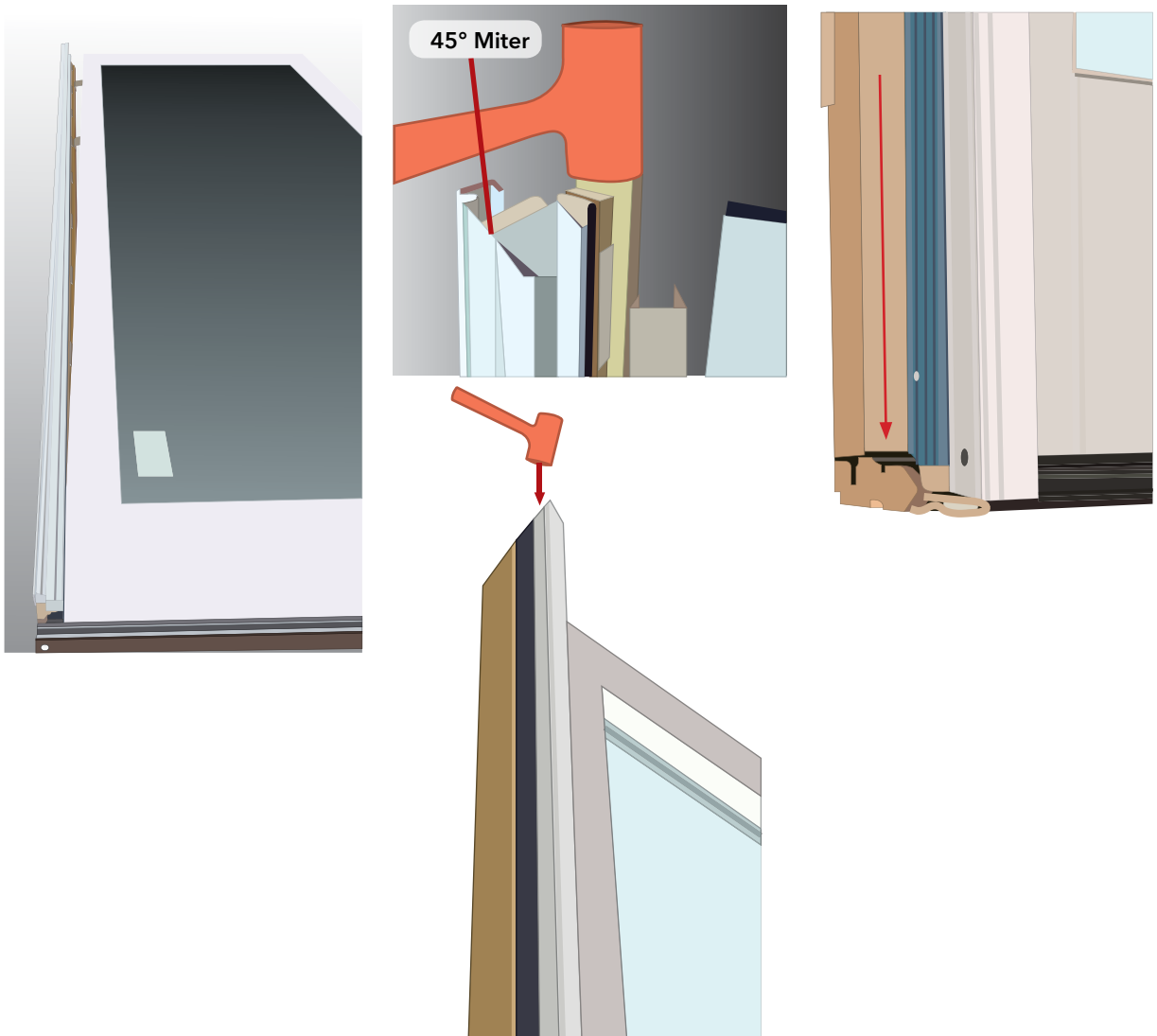

3
Continued

Install sill corner screws through the sill into the jamb. Install short screw first into the exterior cornerlock hole. Then install the three long screws. Hold the jamb cladding flush to sill metal end while driving screws.

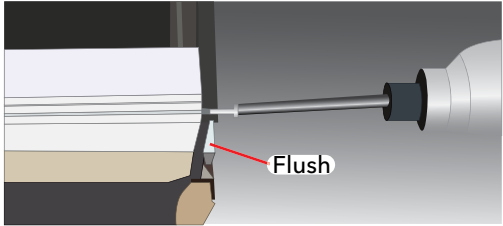
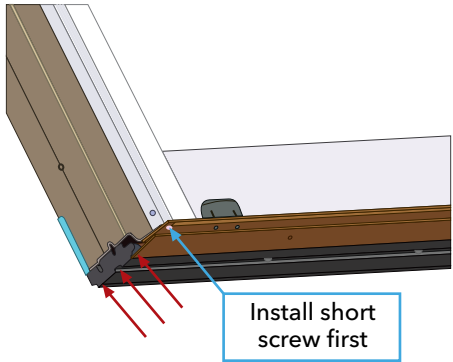

4

FIXED JAMB TO FIXED PANEL ASSEMBLY: Align fixed jamb to panel and install screws into pre-drilled holes.

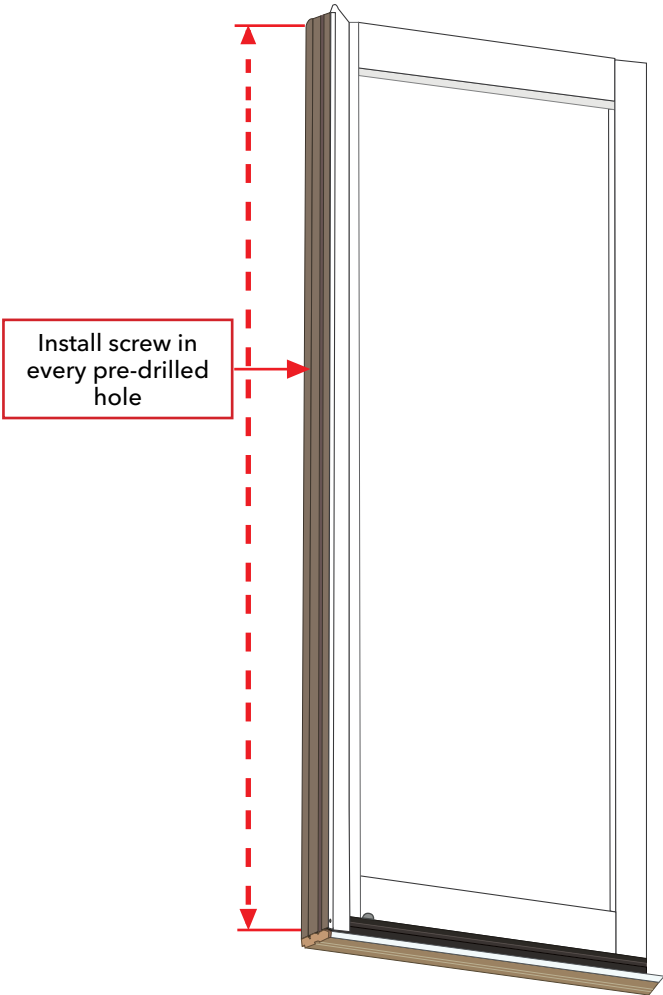
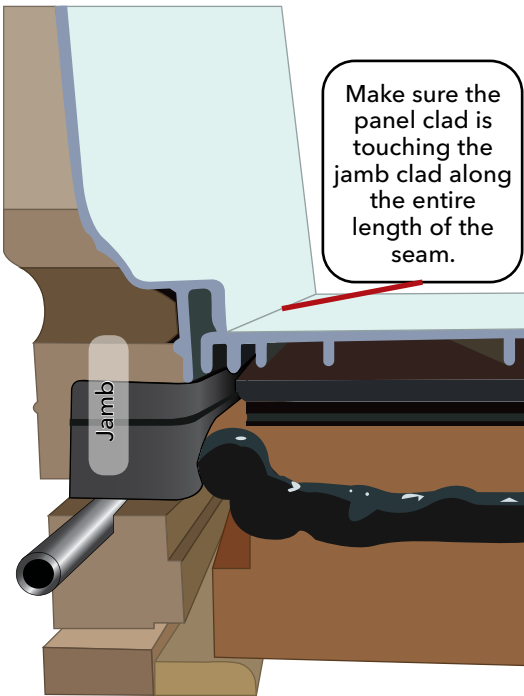

5

LOCK JAMB TO SILL ASSEMBLY: Install lock jamb by aligning lock jamb guide pin with sill guide pin hole. Install short screw first into the exterior cornerlock hole, then install the three long screws.

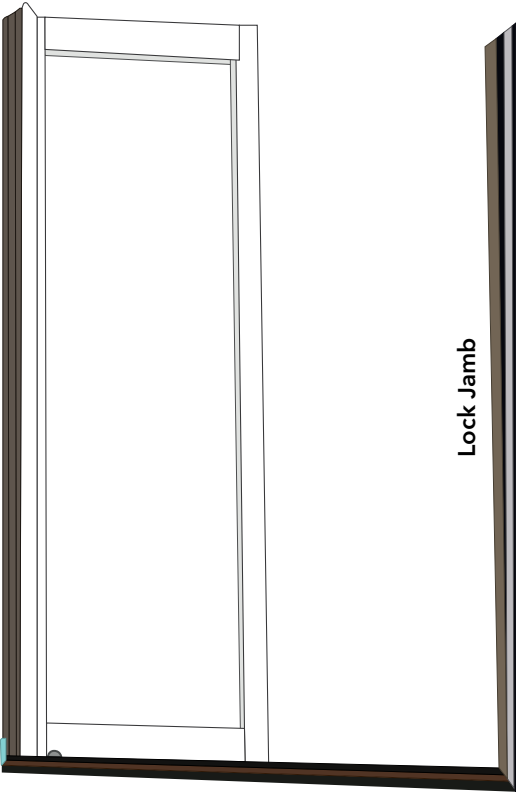
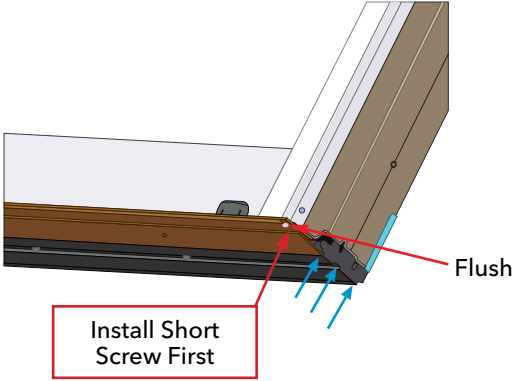

6

HEAD/FIXED JAMB ASSEMBLY: Attach one of the panel spacers found loose in the Head & Sill Package to the head at approximately the center of the panel span.

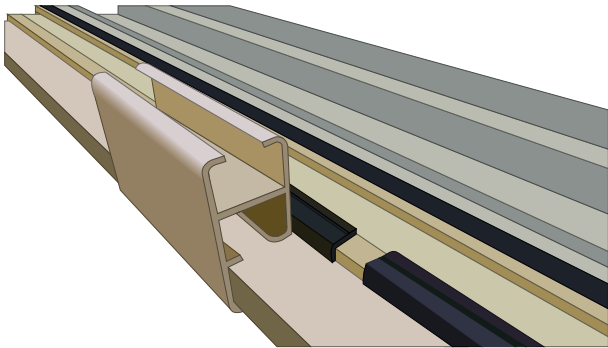
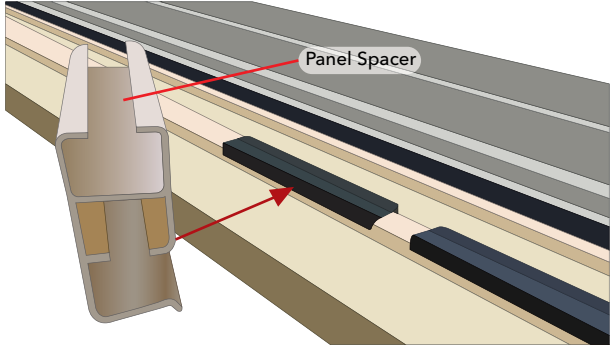

Attach the head by inserting the cornerlocks on each end of the head into the jamb cladding.

Ensure the cornerlock is completely seated into jamb cladding.



Head clad on top of jamb clad

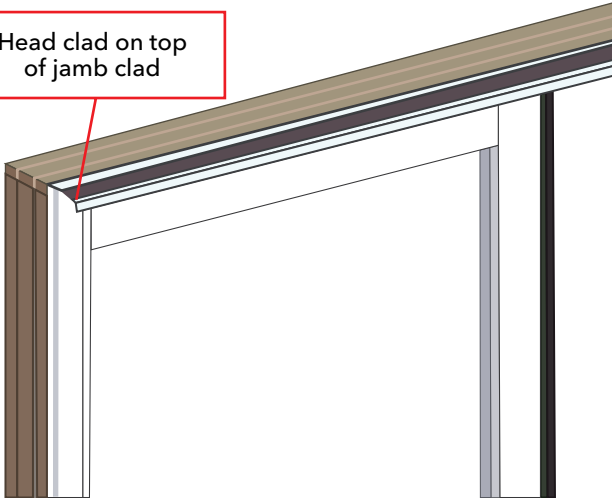

6
Continued

- A. Install the long screws into the wood frame of the jamb.
- B. Inject sealant into the jamb cornerlock screw hole until sealant squeezes-out at miter seam.
- C. While holding the seam closed with hand pressure or corner clamp, install short screw into the cornerlock hole.

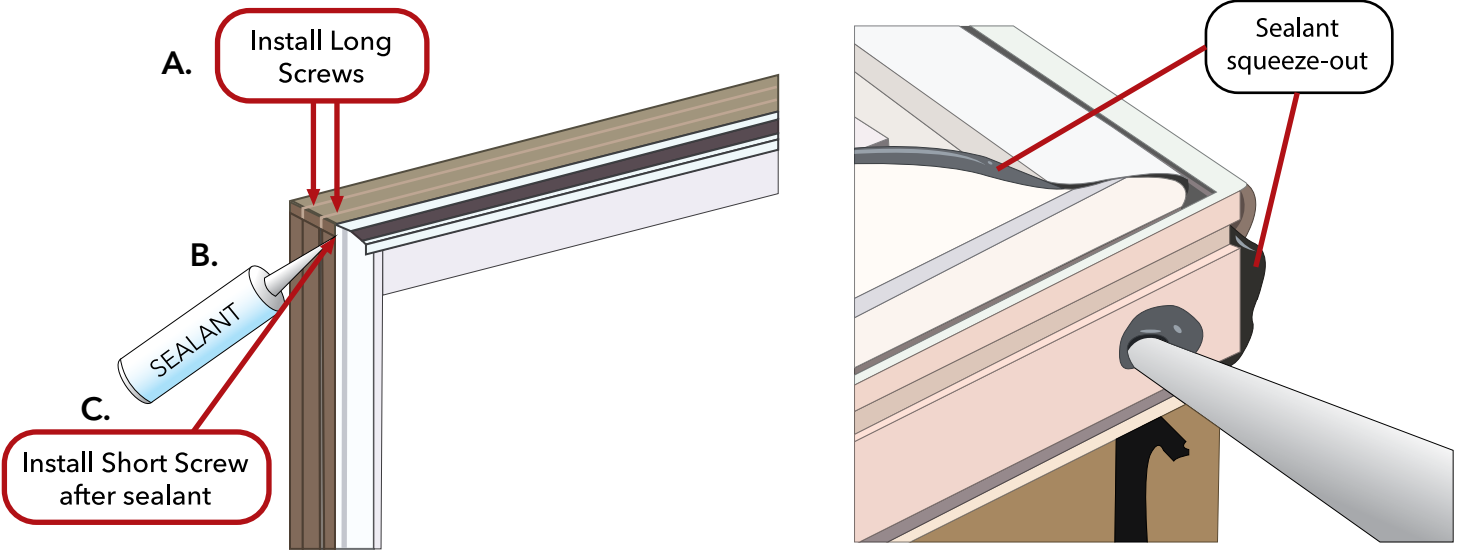

7

HEAD/LOCK JAMB ASSEMBLY:

- A. Install the long screws into the wood frame of the lock jamb.
- B. Inject sealant into the jamb cornerlock screw hole until sealant squeezes-out at miter seam.
- C. While holding the seam closed with hand pressure or corner clamp, install short screw into the cornerlock hole.



8

HEAD TO FIXED PANEL ASSEMBLY: Install the head screws into the pre-drilled holes.

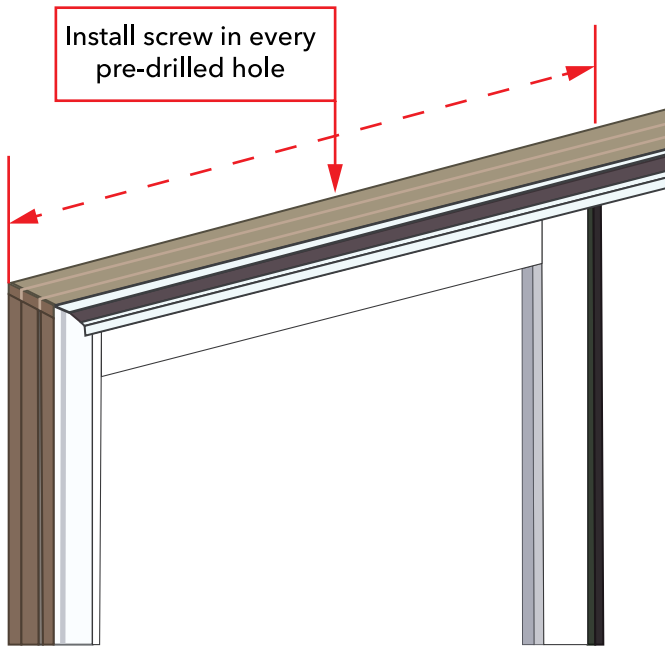

9

Apply sealant to the fixed interlocker jamb stop groove (fill groove completely with sealant - 1/8" from top and flush to sill).

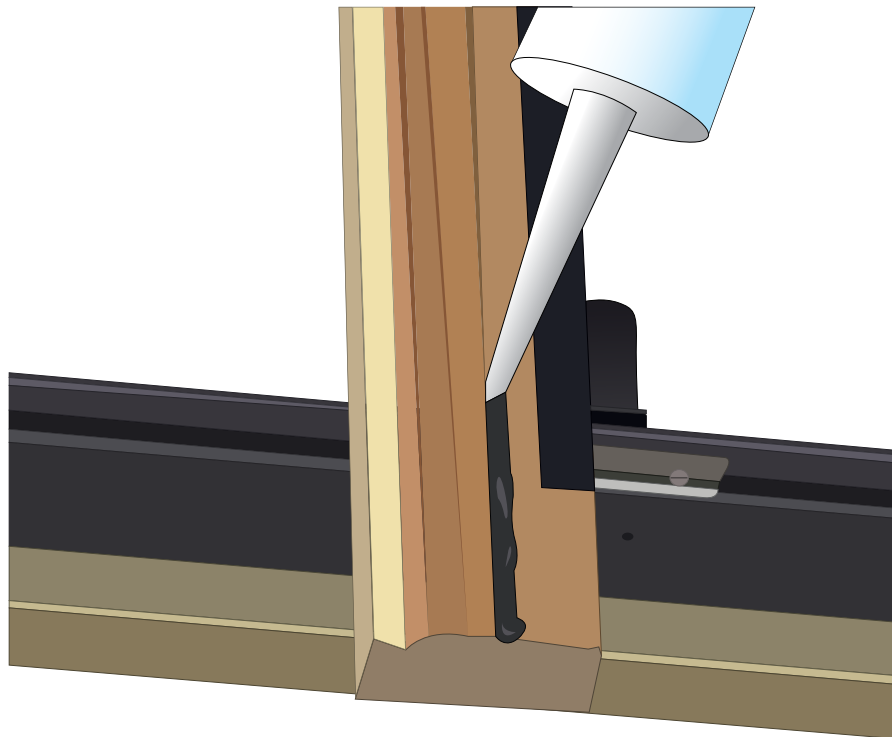

9
Continued

Install Fixed Interlocker Jamb Stop to edge of fixed panel; install sill end first, then the head end. It is necessary to bow the stop away from the panel in the middle while pushing into the panel at the top. Use panel spacers under the panel and the stop to make sure the interior face of the stop is flush with the interior face of the panel.

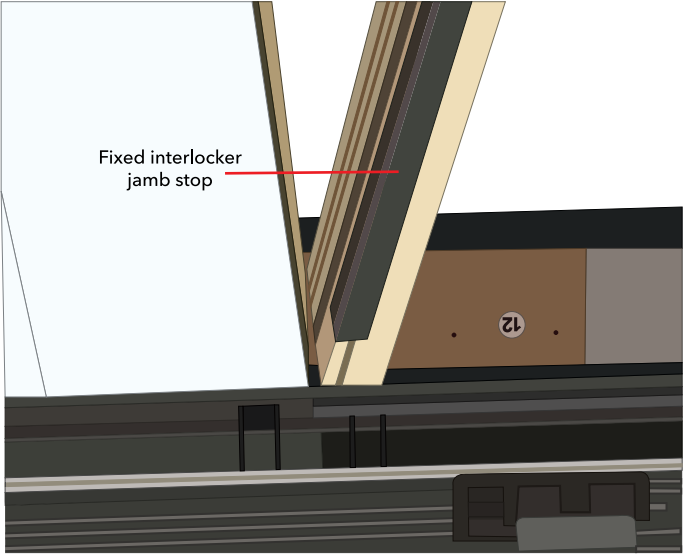

The protruding edges on the stop should engage the groove in the panel edge and lock the stop into place such that there is no interior-to-exterior movement after screw attachment.

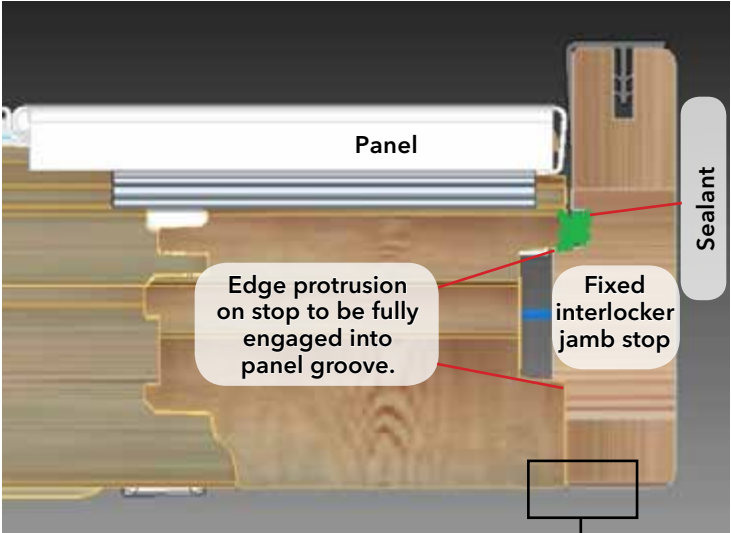
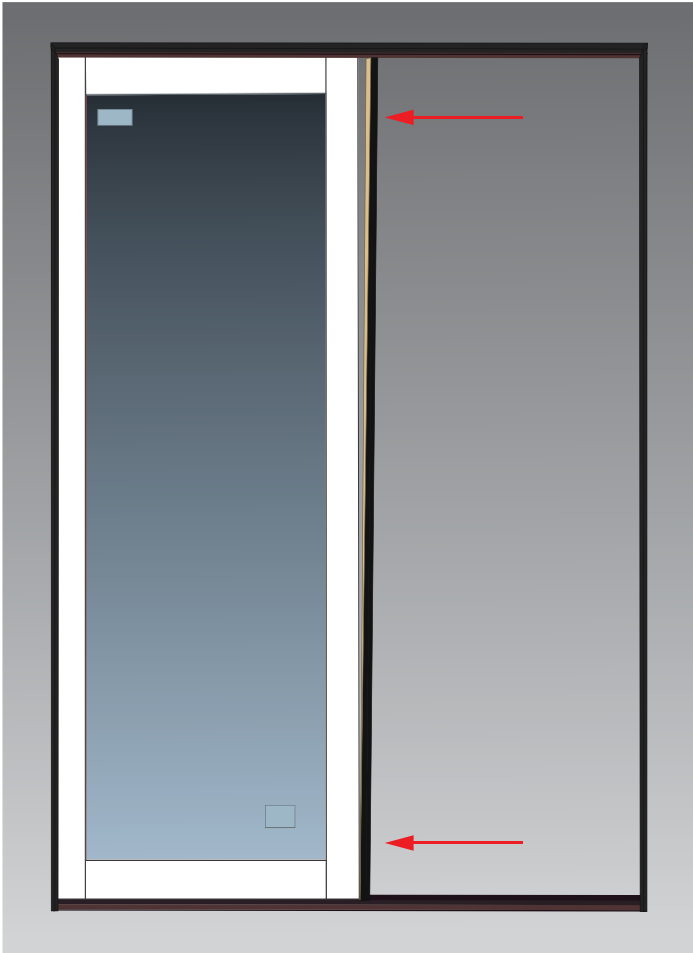
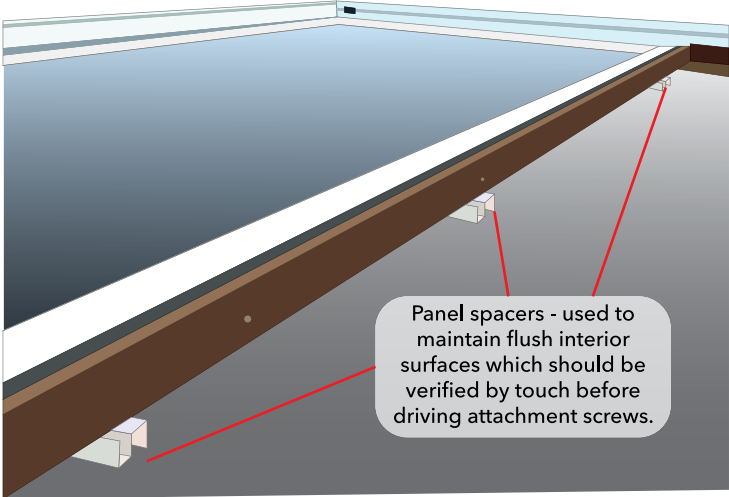
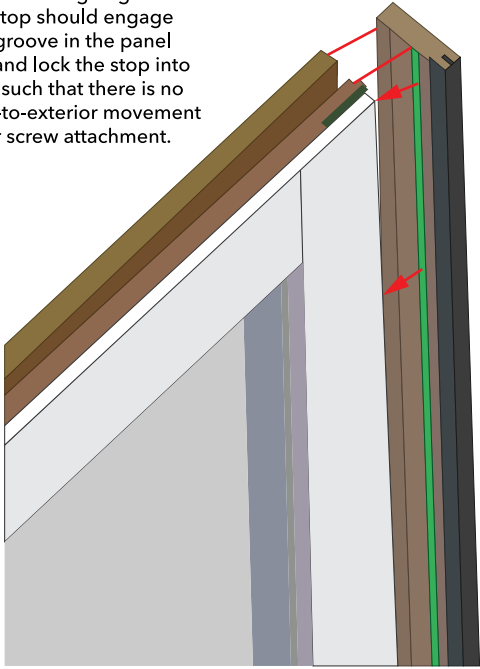

Interior face of Fixed interlocker jamb stop flush with interior face of panel.

Attach with trim screws in every pre-drilled hole. Use clamps to make sure the stop is fully seated.

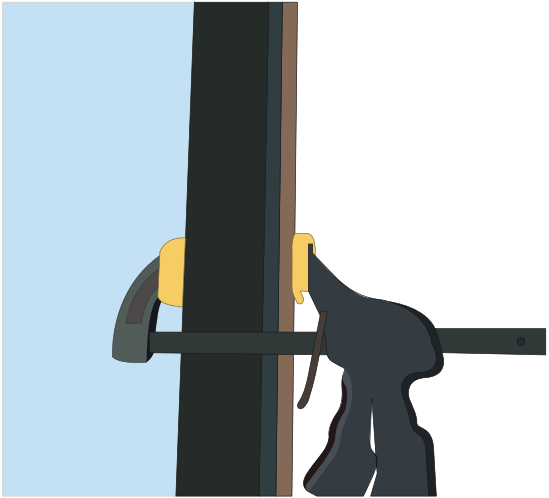
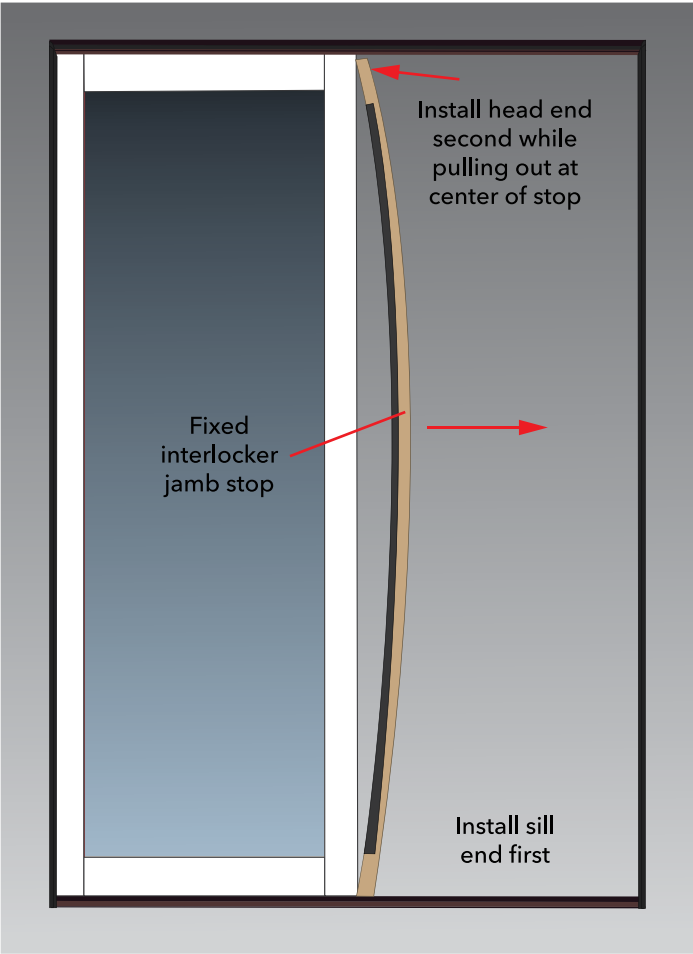

Clamp stop at every screw location

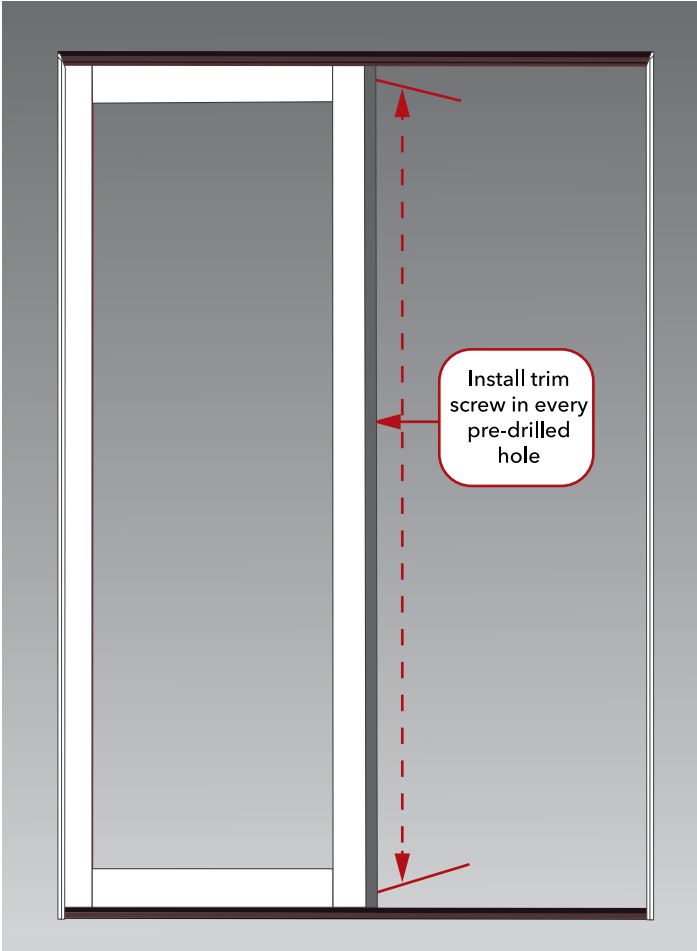

10

SILL END SEAL: On each end of the sill; fold jamb installation fin up at corner, apply sealant at the end of the sill as shown, (fill the grooves with sealant). Place tape over the end of the sill and over the sealant. Make sure tape is not positioned over the installation fin.

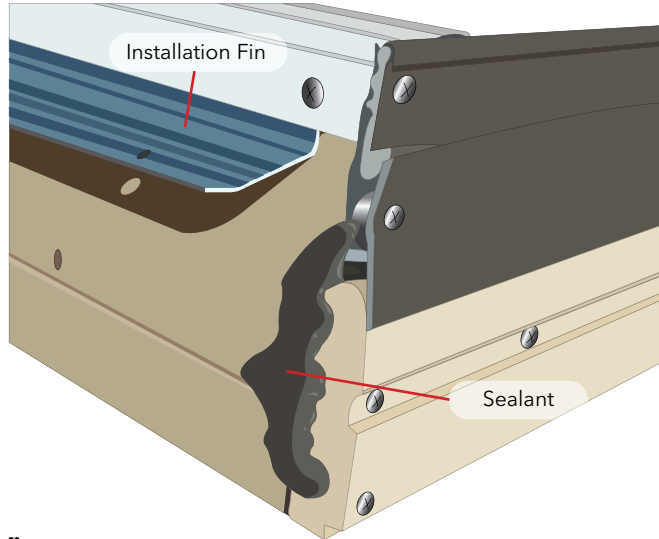
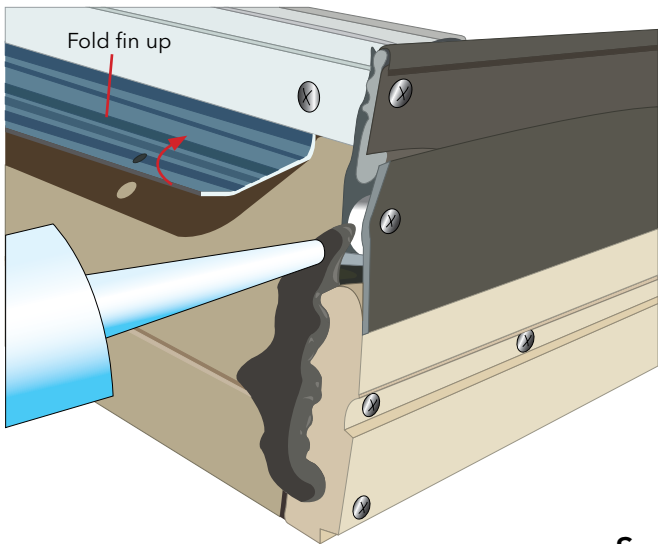

Sealant View

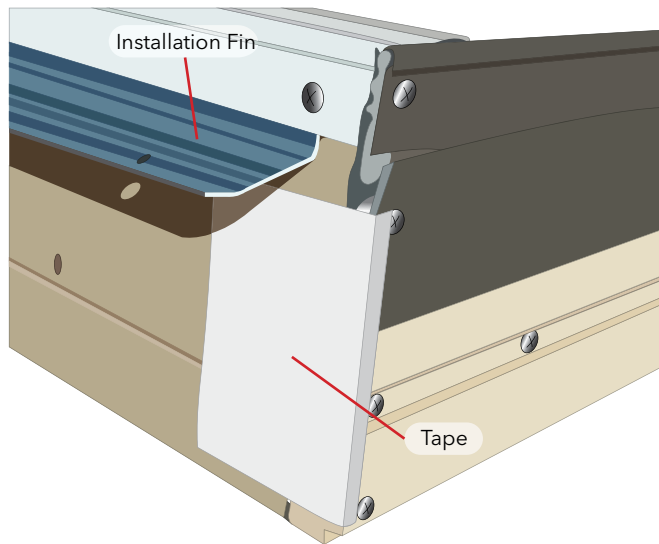
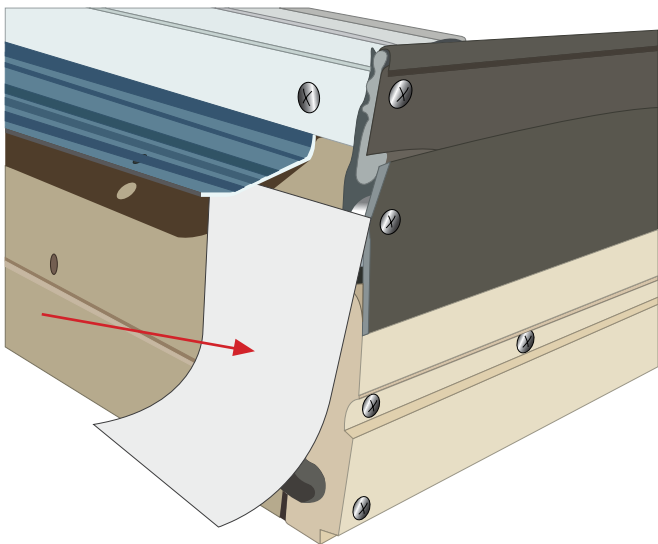

Tape View

11

Install footbolt using included attachment screws.

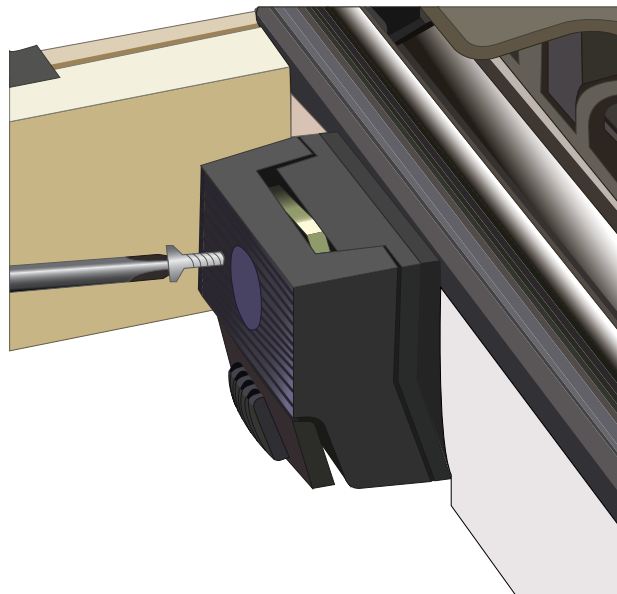

12

INSTALLING THE FIN CORNERS

- A. **Remove the outer portion of the backing** from a new fin corner by pulling on the tab at the corners.
- B. **Align** the front edge of the fin corner with the center of the corner lock screws and the front locating notch with the corner of the product frame.
- C. **Fold the fin corner over** the corner of the product and rub firmly over the entire surface to activate the adhesive and ensure a good seal.
- D. **Lift the installation fin just enough to fold under and adhere the tab** of the fin corner to the back of the installation fin.
- E. **Repeat Steps A - D for the opposite corner** of the product.
- F. **When ready to install, fold out the fin**, stretching the fin corner.

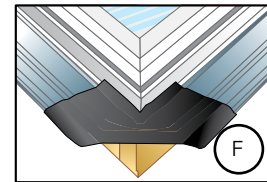
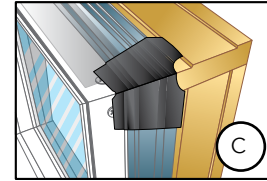
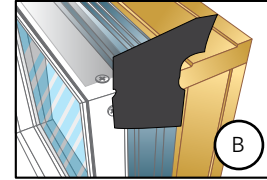
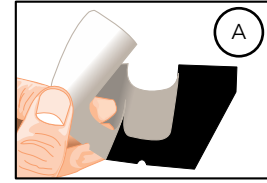

13

Lift unit up and stabilize to remove panel spacers.

14

INSTALLING SCREEN TRACK/HEAD TRIM: Determine if screen is to be installed. If so, follow screen installation instructions. If no screen is installed follow the below steps:

Remove screw package from screen track/head trim. Position screen track with flat side towards frame. Install screw in every pre-punched holes in screen track/head trim.

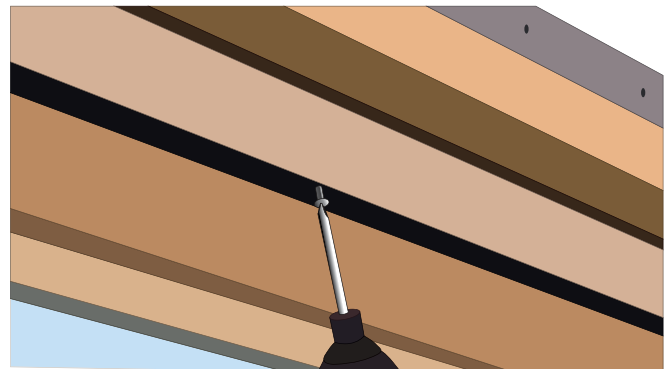
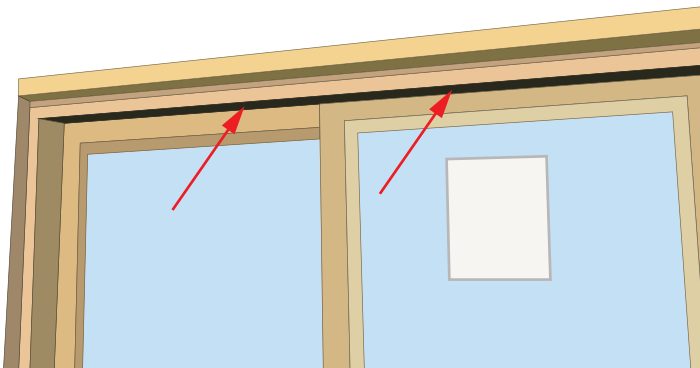

This page left blank intentionally.