



# BONELLI BIFOLD DOOR AND BIFOLD WINDOW INSTALLATION INSTRUCTIONS

---

## Contents:

Part/Tools .....	02
Product Safety Information.....	03
Care and Maintenance .....	04
Installation Information .....	05
Load Verification .....	06
Opening Preparation .....	07
Frame Assembly .....	08
Frame installation.....	11
U-Channel Sill Installation .....	14
Hardware Preparation / Setup / Installation .....	15
Hardware Placement Tips .....	16
Jamb Pivot Information.....	22
Panel Installation .....	24
Panel Adjustments .....	28
Magnet Installation .....	31
Bifold Stucco Key .....	33
Interior and Exterior Sealant .....	35
Sill Pan Instructions.....	36



## BEFORE BEGINNING FRAME ASSEMBLY AND INSTALLATION:

**Read through and understand all the assembly steps and the installation process.**

Carefully remove shipping/packaging materials and check for any product damage.

Confirm the correct product was received. (Size, color, handing, etc..) Confirm all parts as listed in the Hinge Hardware Configuration document are present and accounted for.

If there are any parts missing, product damage, wrong parts, or other issues...



**DO NOT assemble! Contact Pella Customer Service at: 877-473-5527. Or Contact your local sales representative or customer service team.**

Before purchasing and installing, verify performance of product meets the requirements of the application and region. Not all products or sill types are rated for water performance. To reduce the likelihood of water infiltration where application exceeds product performance, install doors under an overhang that extends to meet a 45-degree line from the door sill and slope the exterior 2 degrees away from the door or use a stepdown.

**FAILURE TO DO SO MAY RESULT IN DAMAGE TO THE INTERIOR OF THE STRUCTURE.**

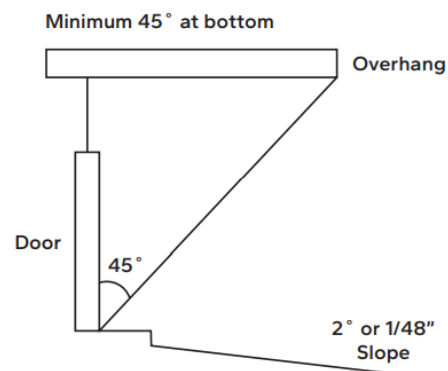

### Tools Needed:

- #2 Phillips handheld screwdriver
- Pry bar
- Level
- Square
- Safety glasses
- Utility knife
- Wood block
- Mallet
- Tape measure
- Drill with 3/8", 9/64", and 3/4" bits
- Drill with masonry bit for concrete applications
- Fine tooth miter saw with aluminum cutting blade
- Sealant gun with polyurethane sealant
- Speed square
- Laser Level (Recommended)

### Supply List (screws/parts not included):

- Moisture resistant shims/spacers (12 to 20)
- Installation Screws: FH #10 x 3" for head and jamb, FH #10 x 1.5" for sill
- Masonry screws for concrete applications (minimum of 3/16" diameter x 3")
- Closed call foam backer rod/sealant backer (21 to 30 ft)
- Foil backed butyl window and door flashing tape
- High quality, multi-purpose window and door installation sealant
- Low expansion, low pressure polyurethane insulating window and door foam sealant. DO NOT use high pressure or latex foams
- Sill pan 6-5/8" x (Rough Opening Width +2)
- Aluminum sill support or wood blocking



# IMPORTANT SAFETY AND PRODUCT INFORMATION

**Safety Alert Symbol Reference:** These symbols are intended to alert you to potential injury hazards and information. Obey all safety messages.



**WARNING** To ensure safety and security and help prevent property damage, including possible damage to your window or door, close and lock windows and doors any time they are not being used for venting on a nice day, and particularly during high winds or rain. Ensure all windows and doors are properly fastened to the wall structure according to the product anchor instructions. It is the responsibility of the Buyer or User, the architect, contractor, installer, or other construction professional to ensure the appropriate windows and doors are chosen for the project and the wall construction is designed to resist all loads in accordance with local building code requirements

**WARNING** Installation may require (2) or more persons for safety reasons.

**CAUTION** Many doors in older homes are painted with lead-based paint. Removal of old doors may disturb this paint. Proper precautions must be taken to minimize exposure to dust and debris. Consult state or local authorities and/or go to [www.epa.gov/lead](http://www.epa.gov/lead) for more information.

**NOTICE** Bonelli products must be stored in an upright, level position not exposed to weather. The storage must be ventilated and provide protection from direct sunlight and excessive temperature.

**IMPORTANT NOTICE** Because all construction must anticipate some water infiltration, it is important that the wall system be designed and constructed to properly manage moisture. Bonelli is not responsible for claims or damages caused by anticipated and unanticipated water infiltration; deficiencies in building design, construction and maintenance; failure to install Bonelli products in accordance with Bonelli's installation instructions; or the use of Bonelli products in wall systems which do not allow for proper management of moisture within the wall systems. The determination of the suitability of all building components, including the use of Bonelli products, as well as the design and installation of flashing and sealing systems are the responsibility of the Buyer or User, the architect, contractor, installer, or other construction professional and are not the responsibility of Bonelli.

Bonelli products should not be used in barrier wall systems which do not allow for proper management of moisture within the wall systems, such as barrier Exterior Insulation and Finish Systems (EIFS) (also known as synthetic stucco) or other non-water managed systems. Except in the states of California, New Mexico, Arizona, Nevada, Utah and Colorado, Bonelli makes no warranty of any kind on and assumes no responsibility for Bonelli windows and doors installed in barrier wall systems. In the states listed above, the installation of Bonelli Products in barrier wall or similar systems must be in accordance with Bonelli's installation instructions

Always read the Limited Warranty before purchasing or installing Bonelli products. BY PURCHASING, INSTALLING OR USING BONELLI PRODUCTS (INCLUDES BONELLI GOODS AND BONELLI SERVICES), YOU AGREED TO THE TERMS OF THE LIMITED WARRANTY AND YOU AND BONELLI and its subsidiaries AGREE TO ARBITRATE DISPUTES ARISING OUT OF OR RELATING TO BONELLI PRODUCTS, AND YOU WAIVE ANY RIGHT TO PARTICIPATE IN A CLASS ACTION RELATED TO BONELLI PRODUCTS unless you opt out of the Arbitration Agreement no later than ninety (90) calendar days from the date you purchased or otherwise took ownership of your Bonelli Products. Opting out of the Arbitration Agreement will not affect the coverage provided by any applicable limited warranty pertaining to your Bonelli products. To opt out, you must send notice by email to [info@bonelli.com](mailto:info@bonelli.com), with the subject line "Arbitration Opt Out". For complete information, including the full terms and conditions of this Arbitration Agreement, which are incorporated herein by reference, please visit [onelli.com/arbitration](http://onelli.com/arbitration) or email to [info@bonelli.com](mailto:info@bonelli.com) with the subject line: "Arbitration Details".



# CARE AND MAINTENANCE

---

**GLASS:** Remove any protective film and labels and clean the glass, using a soft, clean, grit-free cloth and mild soap or detergent. Be sure to remove all liquid by wiping dry or use a clean squeegee.

**NOTICE** DO exercise special care when cleaning coated glass surfaces.

**NOTICE** DO soak the glass surface with clean water and soap solution to loosen dirt.

**NOTICE** DO use a mild, non-abrasive window cleaning solution.

**NOTICE** DO dry all cleaning solutions from window gaskets, sealants and frames.

**NOTICE** DO NOT use scrapers of any size or type for cleaning glass.

**NOTICE** DO NOT apply any other types of film to the glass. Doing so could void product warranty.

**NOTICE** DO NOT allow dirt and residue to remain on glass for an extended period of time.

**NOTICE** DO NOT begin cleaning without rinsing excessive dirt and debris.

**NOTICE** DO NOT use abrasive cleaning solutions or materials.

**NOTICE** DO NOT allow metal parts of cleaning equipment to contact the glass.

**NOTICE** DO NOT trap abrasive particles between the cleaning materials and the glass surface.

**NOTICE** DO NOT lean any tools or materials against the glass surface.

**NOTICE** DO NOT allow splashed materials to dry on the glass surface.

**NOTICE** certain methods of interior shading, particularly the use of tinted films applied directly to the glass can generate excessive heat concentration within the insulating unit and thus lead to premature failure, not covered by glass warranty.

**FRAME:** Excessive debris in the sill can impede the operation of the unit. To maintain the sill track and operation, use the crevice attachment of the vacuum to remove debris. Additionally, ensure weep holes are free of debris at all times to allow for proper drainage.

**NOTICE** The aluminum surfaces of the doors are finished either by means of powder coat painting process, or by an "anodizing" process. In either case, abrasive or caustic cleaners, including paint removers and abrasive materials, such as steel wool, should not be used to remove dirt or debris from these surfaces. Generally, the same cleaning parameters suggested above with regard to insulating glass are also appropriate here.

**HARDWARE:** Hardware is subject to deterioration from everyday use, it is recommended to carry out routine maintenance on all hardware to ensure proper operation.

**NOTICE** To help prevent surface corrosion, wash all hardware with soap or mild detergent and warm water followed by rinsing with clean cold water and wipe dry.

**NOTICE** In coastal or marine environments, it is recommended to apply a light application of corrosion preventative to hardware surfaces and using a dry cloth to remove excess. When using lubricant or corrosion protection compounds, be careful to avoid the adjacent surfaces and always follow the manufacturer's instructions (Applies to Hanger/Pivots, Guides, and Hinges).



# INSTALLATION INSTRUCTIONS FOR TYPICAL WOOD FRAME CONSTRUCTION

These instructions were developed and tested for use with typical wood frame wall construction in a wall system designed to manage water. These instructions are not to be used with any other construction method.

Building designs, construction methods, building materials, and site conditions unique to your project may require an installation method different from these instructions and additional care. Determining the appropriate installation method is the responsibility of you, your architect, or construction professional.

**NOTICE** With multiple tracks it's very important to make sure the threshold is level the entire length of the opening and the distance from the interior to exterior.

**NOTICE** FAILURE TO PROVIDE ADEQUATE ROUGH OPENING SILL PROTECTION FOR WOOD THRESHOLDS WILL VOID PRODUCT WARRANTY.

**NOTICE** Proper steps must be taken when flashing and applying sealant to ensure proper waterproofing of the unit.

## METHOD OF INSTALLATION

Due to the complexity of the Folding Door System and the lengthy install manual it is highly suggested the install is done step by step with the manual.

It is recommended to read each section individually followed by the hands on install of that particular section. It is very important to thoroughly understand and follow each section of instructions as written. Failure to do so could result in faulty install.

Products with U-Channel and Flush Sills are not rated for water or air performance and must be installed in a protected area such as an appropriate overhang.

**Refer to Page 14 U-Channel sill example details, if applicable.**

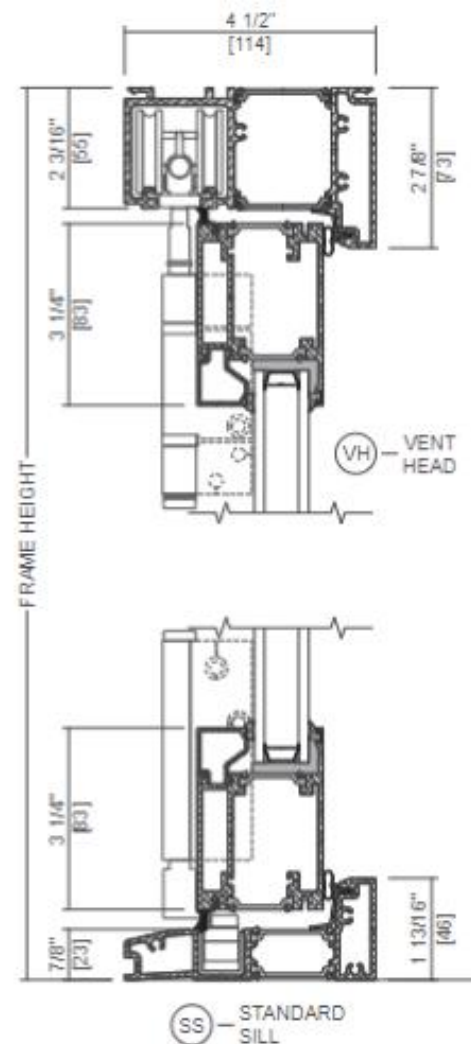



# HEADER AND LOAD VERIFICATION

**CAUTION** Fully inspect the opening before you begin. Verify if the header is a solid beam or if there is any material furring down the opening. If there is lumber furring down the opening, make sure it is strapped down with something like ST22 type straps. Due to these doors being hung from the header of the frame, a furring strip just nailed will not hold the weight of the door and in time the furring strips will start to pull away and sag causing the door to be out of alignment and possibly drag across the threshold damaging it. These straps should go from the top of the header down the exterior face, under the header and furring material, then back up the opposite side and up the interior face to the top. Depending on the size of the door, position these straps in more than one location from the center working out towards the jambs.

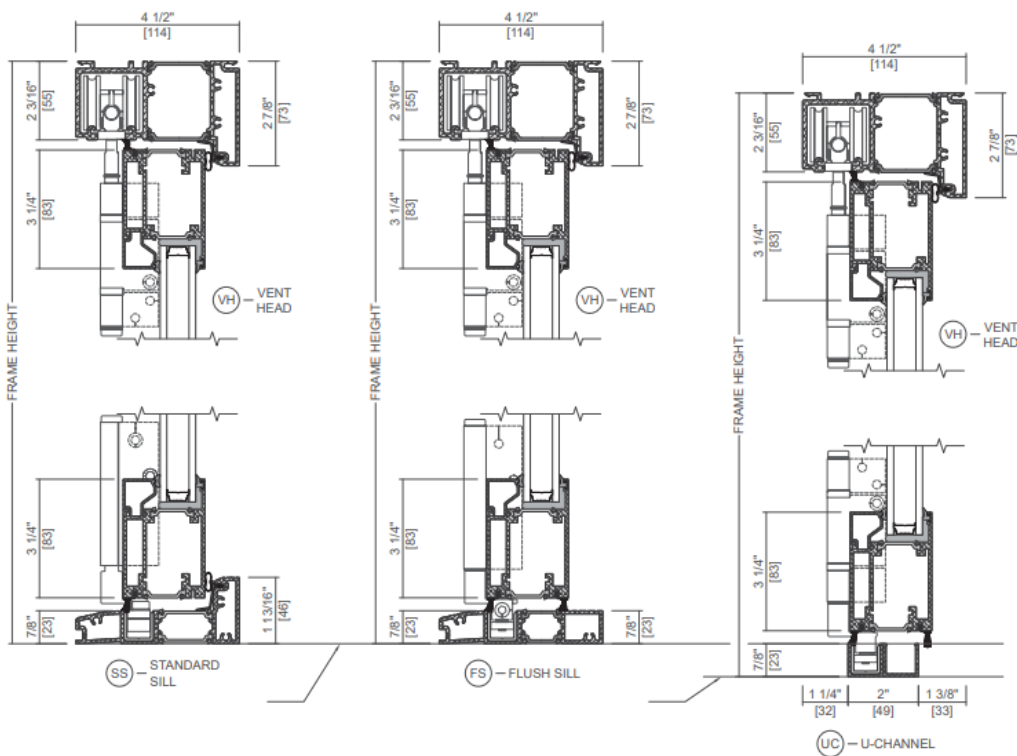

## IMPORTANT NOTICE

### \*Header Notes:

- Add 10lbs per square foot of door opening to header load requirements.
- Header cannot deflect more than 1/8" over span.
- Solid header must be directly above door for proper anchoring and load requirement

# 1 Opening Preparation:

- A. **Confirm the opening is plumb and level.**

**NOTICE** It is critical the bottom is level and does not slope to the interior or exterior. The rough open must be within 1/8" tolerance of being plumb and level before proceeding.

- B. **Remove dirt, oil or debris** from the opening and surrounding wall surfaces.

- C. **Confirm the door will fit the opening.** Measure all four sides of the opening to make sure it is 1/2" to 3/4" larger than the door in both width and 1/2" larger in height. Measure the width and height in several places to ensure the header or studs are not bowed.

**NOTICE** 1-1/2" or more of solid wood blocking is required around the perimeter of the opening. Fix any problems with the rough opening before proceeding.

**NOTICE** It is important to consider the door's exposure to weather, the exterior landing surface type and its proximity to the door sill, and to confirm impervious exterior surfaces properly slope away from the door prior to continuing installation.

- D. **Cut the building wrap.**

- E. **Fold the building wrap in at the jambs and staple it in place.** Fold the top flap up and temporarily fasten with flashing tape

**NOTICE** If using a sill pan or if the door will be installed on a concrete slab, refer to the instruction page at the end of this instruction. When installing on wooden subfloors, it is advised to utilize a sill pan.

- F. **Cut two pieces of flashing tape** 12" longer than the opening width.

- G. **Apply sill flashing tape #1** at the sill extending 1" to the exterior and 6" up each jamb.

- H. **Cut 1" wide tabs** at each corner by tearing the foil 1/2" each way from the corner.

- I. **Apply sill flashing tape #2** overlapping tape #1 by at least 1" by 1" minimum.

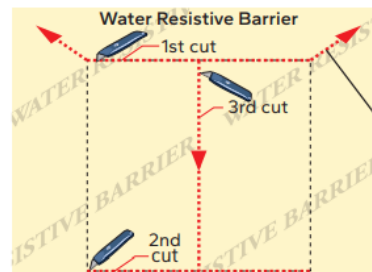

1D

4th cut: Make a 6" cut up from each top corner at a 45° angle to allow the water resistant barrier to be lapped over the fin at the head of the door.

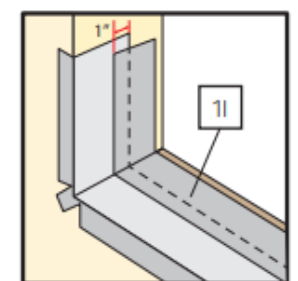
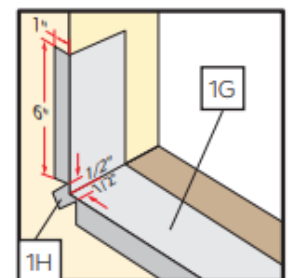
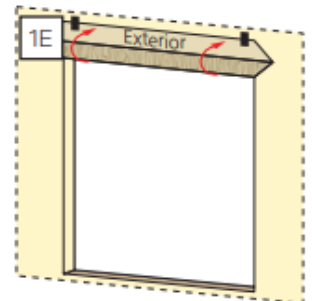

## 2 Frame Assembly:

A. Unwrap packaged frame and identify frame parts necessary (head, 2 jambs, and a sill). The sill type can be determined by referencing the cross-sections shown below (Standard, Flush, or U-Channel).

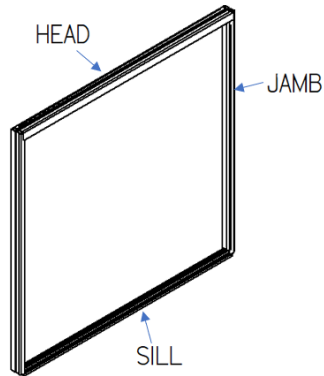

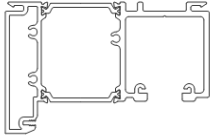
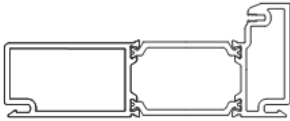
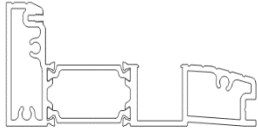
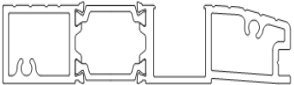
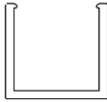
<p style="text-align: center;">Head</p> 	<p style="text-align: center;">Jamb</p> 	<p style="text-align: center;">Standard Sill</p> 
<p style="text-align: center;">Flush Sill</p> 	<p style="text-align: center;">U-Channel (2 channels- one with plastic guide pre-installed)</p> 	

## 2 Frame Assembly (continued):

**NOTICE** The holes in the head will be predrilled.

**NOTICE** Please refer to Pg. 39 for the stucco key installation process.

- A. Position the head, sill and 2 side jambs weatherstrip side down on a clean flat surface in the orientation in which they will be assembled. Insert wood blocks under each corner to support and level the corners on an uneven surface. Or position the frame parts on sawhorses.

Be sure to assemble one frame corner at a time. Joining the head to the jambs first, followed by the sill to the jambs. If using a U-channel sill, the sill will not be connected to the jambs, please refer to [Pg. 14 U-Channel Sill Installation](#) for more information before proceeding.

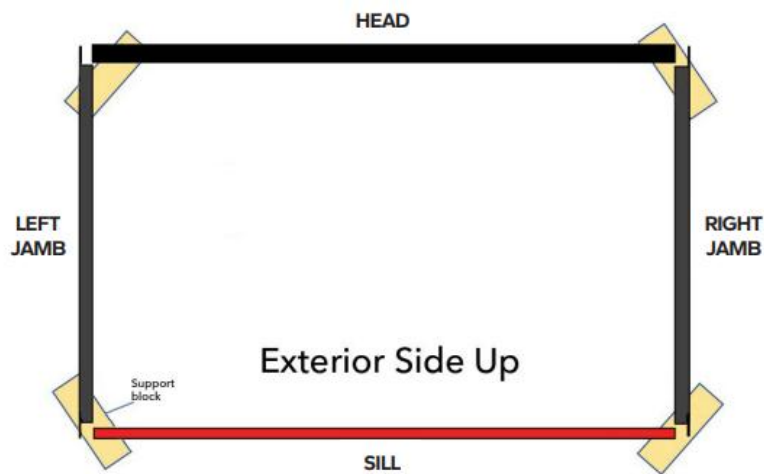

- B. Bring the left (or right) jamb to the head and set in place. Match the relief notch on the jamb to the leg height on the head.

**NOTICE** The side of the jamb with the relief notch should interact with the head of the frame.

**NOTICE** The jamb may have two different relief notches depending on the sill type used. Ensure accurate matching of the notch based on the leg height.

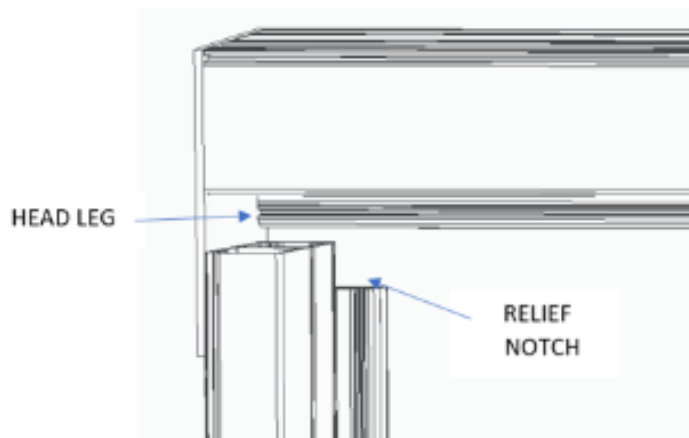

## 2 Frame Assembly (continued):

- C. Position the top end of the jamb to the bottom surface of the head, aligning the back of the jamb to the endplate. Apply polyurethane sealant to the mating surfaces of the jamb and head to ensure a watertight seal. Clean all excess sealant.

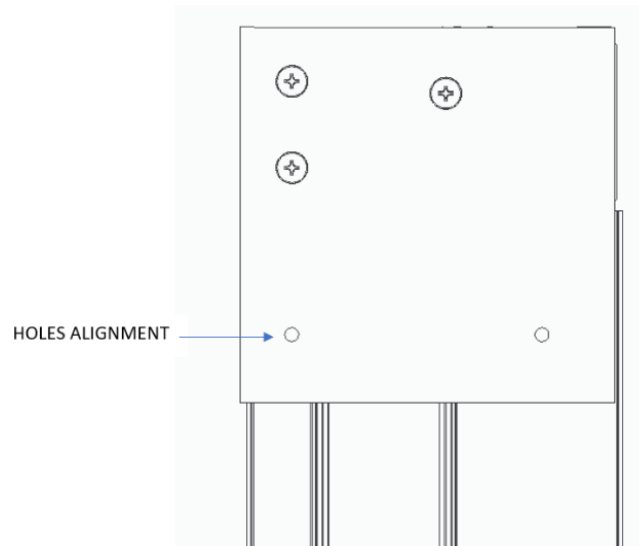

- D. Push the packaged pan head frame assembly screws (#10-3/4") through the endplate on the head. Start each screw aligning it with the correct screw bases on the jamb.
- E. One corner at a time, make sure each screw is aligned with the proper screw base, and tighten each screw sequentially and evenly until the jamb is tightened firmly against the head and/or sill. Be careful not to over torque or strip out the aluminum or pull through the jamb walls.

**NOTICE** Use care if using an impact driver during the Frame Assembly Process. Impact drivers can cause screw head breakage.

- F. Repeat for other jamb-to head connection.
- G. Repeat the same process for the frame's sill.

### 3 Frame Installation:

- A. **Place three 3/8" beads of sealant across the opening sill.** Place the interior-most bead 1/2" from where the interior of the door sill will remain after installation. Continue this bead up the sill pan lip, if applicable.
- B. **Place a second bead beginning from the interior bead 1/2" from each side, out to the exterior of the framing and along the opening.** Leave 2" voids 4" from the corner and at center. Place a third bead along the exterior side of the sill. Extend sealant 6" up each jamb.

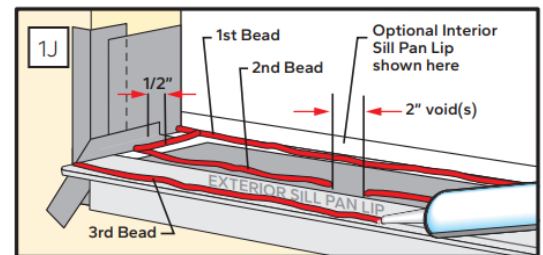
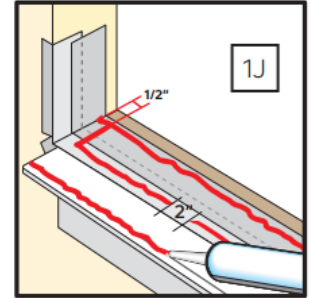

- C. **Confirm** the sill is level, free of any crowns and sags.
- D. **Center the bottom of the door in the opening** and tilt the door into position. Do not slide the door into the opening. Sliding will damage the sealant lines. Check the jambs for plumb and confirm there is room for shimming between the jambs and opening on each side. Confirm the sill is level.
- E. **While a helper holds the door in place, walk across the sill** to compress the sealant and confirm the frame is firmly on the threshold, free of any humps due to the sealant under it.
- F. **With the frame screws (#10 – 1-1/2"), and shims behind each screw** using the pre-drilled frame screw installation holes, secure the four corners. Measure the frame diagonally to confirm it is square.

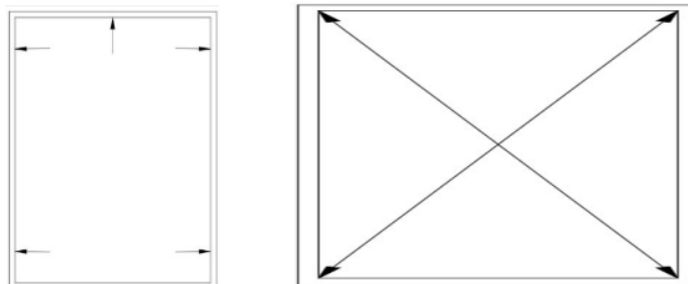

- G. **Using the recommended, #10-2-1/2" screws**, insert one screw in the pre-drilled holes nearest to the center of the head to keep the head from sagging.

### 3 Frame Installation (continued):

- H. From the interior, pick one side of the frame and measure the daylight opening height near the jamb. Then measure the daylight opening at the center.
- I. Using the center screw from Step 3G to lift and crown the head of the door frame 1/8".

**Crowning Guidelines:** Crowning the frame head of the folding door is a very important step, not done or done incorrectly can cause damage to the door and faulty operation.

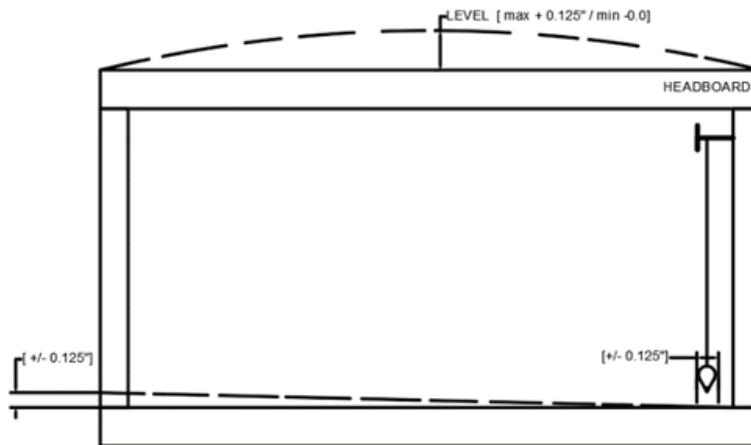

**NOTICE** Ensure all holes in the head of the frame are countersunk and flush with the head channel surface.

**NOTICE** Ensure the head is plumb with no bow towards the interior or exterior of the opening.

- J. Once the crown is set at the appropriate height, finish securing the frame.

**Secure the jambs** of the frame placing #10-3" screws in all the pre-drilled frame holes. Every hole must be used.

**NOTICE** Ensure that the screws go through both pre-drilled frame holes. Reference picture on the right for example.

**Place shims at every screw location** to eliminate any frame movement (shim at least 16" on the jambs). Use level to make sure the jamb is plumb side to side and there is no daylight between the level and the frame. Level and secure the jambs making them perfectly straight.

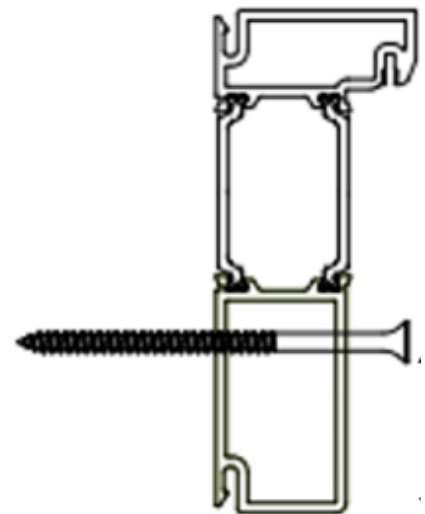

### 3 Frame Installation (continued):

- K. **Secure the head of the door frame placing the screws in all pre-drilled frame holes.**

**Place shims at every screw location** to eliminate any frame movement (shim every 16" on the frame head).  
Use a level to make sure there is no daylight between the level and the frame.

- L. **Once the frame is square**, use #10-1/2" anchors to secure the sill to the opening. Ensuring all screw heads are countersunk and flush with the sill channel surface.

**NOTICE** Use a vacuum to remove debris from the sill once this step is complete. Additionally, use a clean cloth to clean out both sides of the head track where the panel carrier set hardware will be installed.

## U-CHANNEL SILL INSTALLATION:

**IMPORTANT NOTICE** The U-channel sill is not able to withstand air and water intrusion like the weather resistant sill. This option has no weep or drainage incorporated into the track; therefore, an overhang is important protection over this type of sill.

On a U-channel sill application, the frame will be 3-sided and with a U-channel for the bottom. This install requires knowing what the finished floor or countertop will be in order to determine where to set the height of the U-Channel.

Depending on the finished floor or counter, a notch may be needed to flush the sill to the level of the finished surface. Net size of the U-channel width is 1.94" wide by 0.91" tall. If cutting a channel in a finished floor or counter, a 1/8" gap around the sill is recommended to allow it to be adjusted accordingly.

Flash the opening according to AAMA standards.

The U-channel sill consists of two channels (shown below). When placing the sill, ensure the aluminum channel is on the interior side of the opening, while the aluminum channel with vinyl interior is facing the exterior of the opening.

To secure the sill, drive screws through pre-drilled holes.

**NOTICE** In masonry applications, to secure the sill, use masonry anchors. Once anchors are placed, drive screws through the predrilled holes.

After the U-Channel sill has been secured, install the frame. There will be no end plates used to attach the sill to the jambs, so the frame will sit on top of the U-Channel.

**NOTICE** Use a vacuum to remove debris from the sill once this step is complete.

Continue with *Hardware Preparation/Set-Up/Installation on Page 15*.

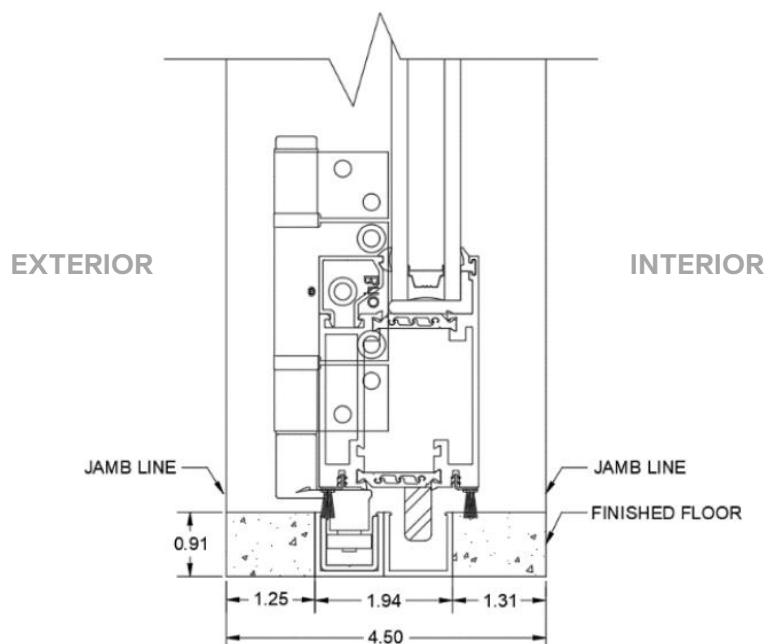

# 4 Hardware Preparation/Set-Up/Installation:

**NOTICE** In the hardware box there will be a hinge hardware configuration sheet. This sheet will show the hardware included in the box, along with hardware already installed on the panel(s). Every sheet is specific to the door ordered.



**Study the hardware configuration sheet.** This sheet is key to a successful installation! Below is an example of a 0L-2R configuration. Please refer to the hardware configuration sheet for the hardware included for your specific configuration.

**Bonelli Bifold Hinge Hardware Configurations**

**0L-2R**

- Hardware Box
  - 1 Pivot set
  - 1 Jamb Pivot
  - 1 End Carrier set
- On Panel
  - 1 Straight (Hinge) (Hinge) w/ handle set

End Set (BWS2-100SH)

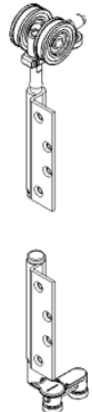

Hinge Handle Set (**Attached to Panel - BW3-100H**)

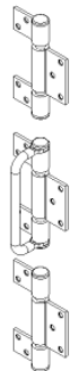

Pivot Set (BWS1-100H)

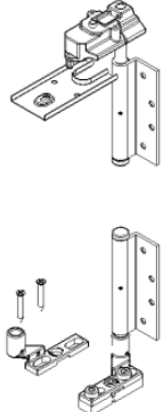

Jamb Pivot Set (BW189H)



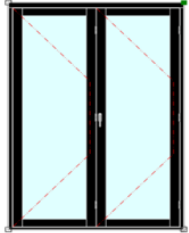

**NOTICE** Hardware will come in boxes labeled A, B, and C. The hardware in each box will match up with the identically labeled panel(s).

## Hardware Placement Tips:

All hardware will come pre-handed and adjusted, so there should be no need to adjust the hardware before installing.

Determining hardware placement is key to a successful panel installation. Hardware configuration will differ depending on configuration. Below are some tips on determining placement prior to hardware installation.

### One-way (non bi-parting):

- Even Panel (Ex:4L-0R, 6L-0R, etc.): End carrier will be inserted first, followed by the intermediate carrier(s) if applicable, and lastly the pivot carrier.
- Odd Panel (5L-0R, 7L-0R, etc.): With odd configurations, no end carriers are needed. So, the intermediate carrier(s) will be inserted first, followed by the pivot carrier last.

### Two-Way (bi-parting – ex: 2L-4R, 3L-4R, etc.):

- For bi-parting units, it may be helpful to treat each side of the unit as separate configurations (Ex: if your unit configuration is 3L-4R, when placing hardware think of this as a 3-panel unit and 4-panel unit *NOT* a 7-panel unit).
- For bi-parting units, there will be two pivot cut outs on both sides of the head.
  - If there's an even panel configuration on one or both sides of the stack, the end carrier will be inserted first, followed by the intermediate carrier(s) if applicable, and lastly the pivot carrier.
  - If there's an odd panel configuration on one or both sides of the stack, no end carriers are needed. So the intermediate carrier(s) will be inserted first, followed by the pivot carrier last



**End Carrier Set**

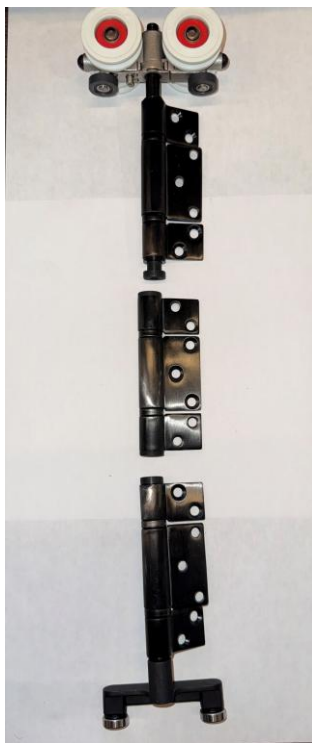

**Intermediate Carrier Set**



**Pivot Carrier Set**

## 4 Hardware Preparation/Set-Up/Installation (continued):

- A. Insert the carrier rollers into the head of the frame through the pivot cut out. The configuration of the door being installed will determine the order the hardware is put in.

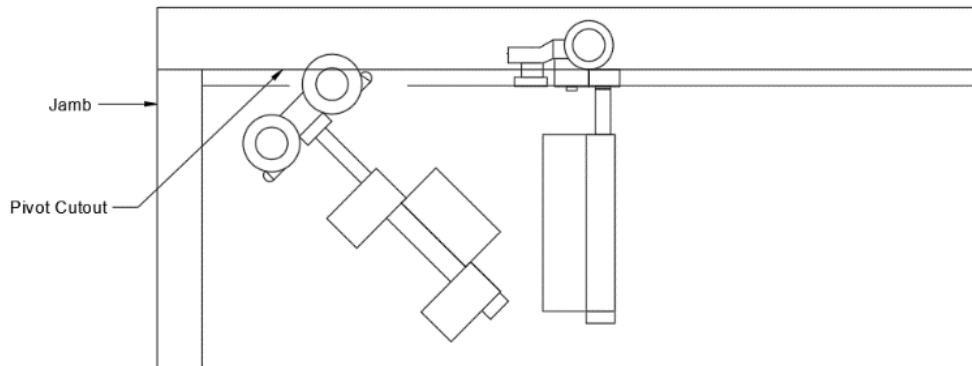

If the door set up has any group of panels ending on an even number, the end carrier will be inserted first. Install the roller into the hole routed out on the stacking side of the frame. The horizontal wheel side goes in first. All the other intermediate carrier sets will be installed in the same routed out hole.

If the door set up has any group of panels ending in an odd number, the intermediate carriers will be inserted first. When inserting the intermediate carriers, the depress button should be facing away from the pivot cut out.

**NOTICE** Insert the carrier that slides to the opposite side of the head first to ensure the carriers are in the correct order. For one-way configurations, there will be one pivot cut out, while bi-parting configurations will have two pivot cut outs.

## 4 Hardware Preparation/Set-Up/Installation (continued):

- B. Insert the remainder of the carrier hardware into the head.
- C. **Once the end and intermediate carriers have been inserted in the top track,** insert the top pivot carrier. The top pivot carrier should be inserted, extended, and adjusted to the end prior to installation, please verify per images below.

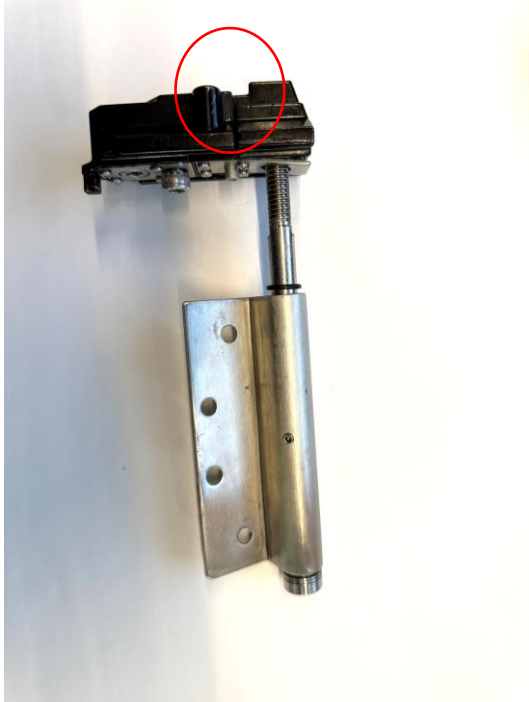

Top Pivot – Not Extended



Top Pivot – Extended

- D. **Before proceeding, ensure the hardware orientation is correct.** As mentioned above, on the intermediate carrier, the depress button should be facing away from the pivot carrier and towards the end carrier (if applicable).

Refer to graphic below for hardware orientation.

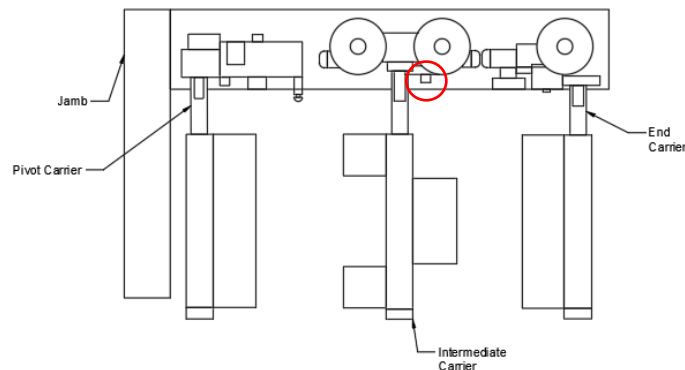

**NOTICE** The hardware placement is dependent on product configuration. If the pivot carrier is on the opposite end, hardware placement will need to be inverted.

## 4 Hardware Preparation/Set-Up/Installation (continued):

- E. Once the pivot carrier has been inserted into the slot on the head and hardware orientation has been verified, anchor the pivot carrier through the two pilot holes in the head using the provided screws located in the hardware box.

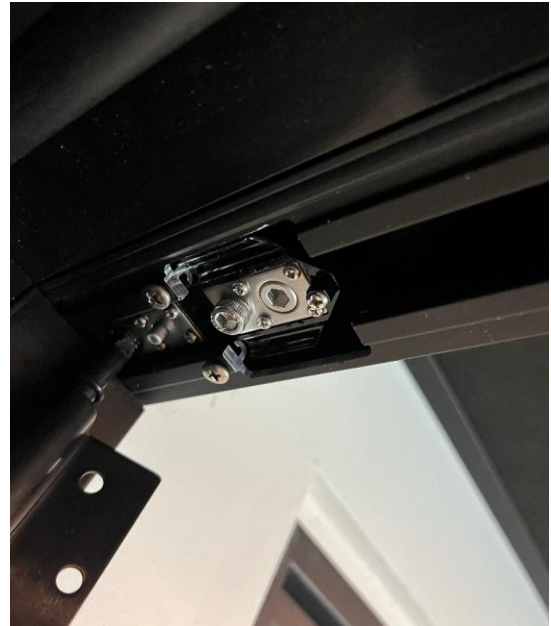
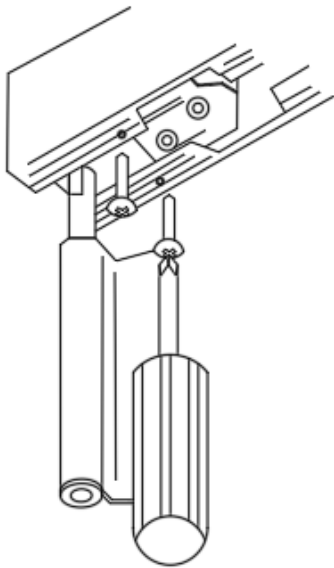

**NOTICE** When securing, ensure the top pivot hinge is in contact with the jamb, like the picture below. If not, loosen the locking screw and adjust the top pivot until the hinge is in contact with the jamb. Once in contact, tighten and lock in this position.

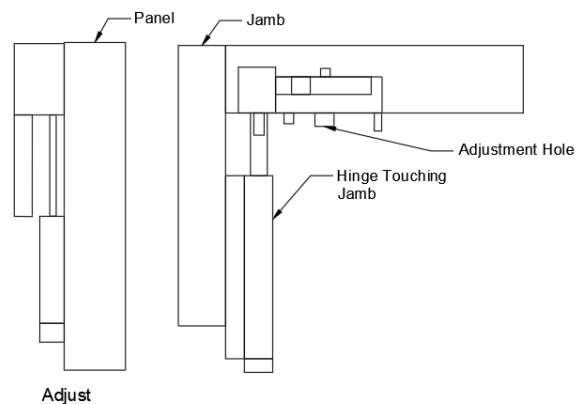

- F. Once the pivot carrier is secure and the hinge is in contact with the jamb, locate the pivot cover in the hardware box and secure the cover to the pivot carrier with provided screws.

## 4 Hardware Preparation/Set-Up/Installation (continued):

- G. Identify the bottom sill pivot hardware and ensure accurate handing based on configuration.** Hardware should be handed properly straight from the box. Viewed from the exterior, a unit stacking to the left will need left pivot hardware and units stacking to the right will need right pivot hardware. Bi-parting units will need both. Below are examples of Left and Right handing:



**Left Handed Sill Pivot Hardware**



**Right Handed Sill Pivot Hardware**

- H. Place bottom pivot hardware in the channel in the sill.**

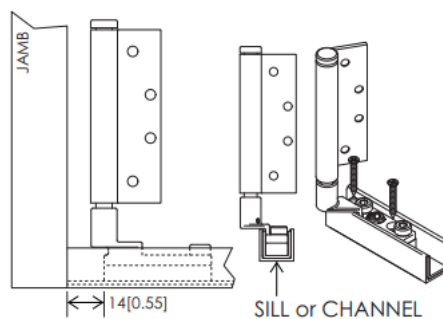

Secure pivot hardware to the sill with pre-drilled anchor holes with the provided screws in the hardware box.

## 4 Hardware Preparation/Set-Up/Installation (continued):

- I. Once secured to the frame, loosen the locking screws and adjust bottom pivot so the hinge is touching the jamb. Once in contact with the jamb, tighten and lock in this position.

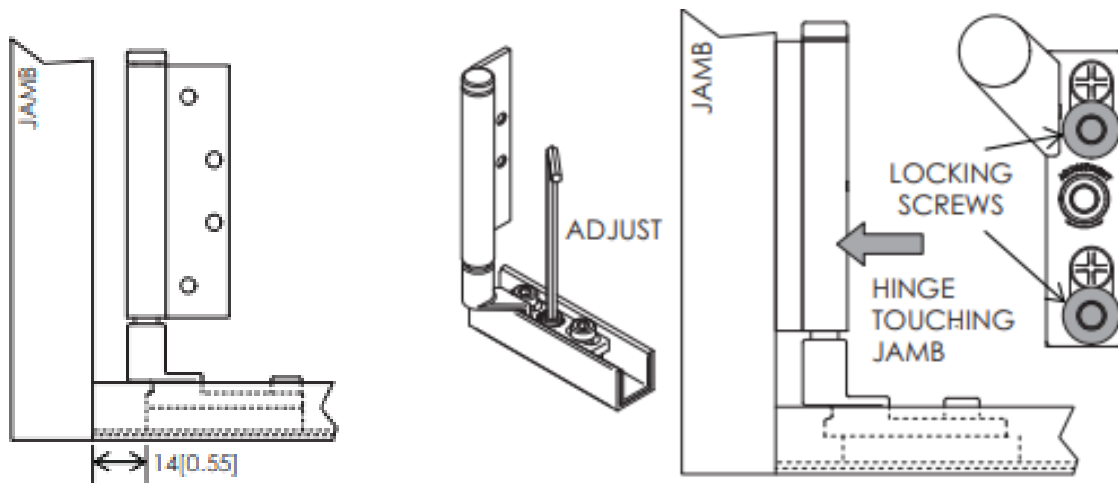

- J. Once the bottom pivot hardware has been secured, locate the bottom carriers in the hardware box.

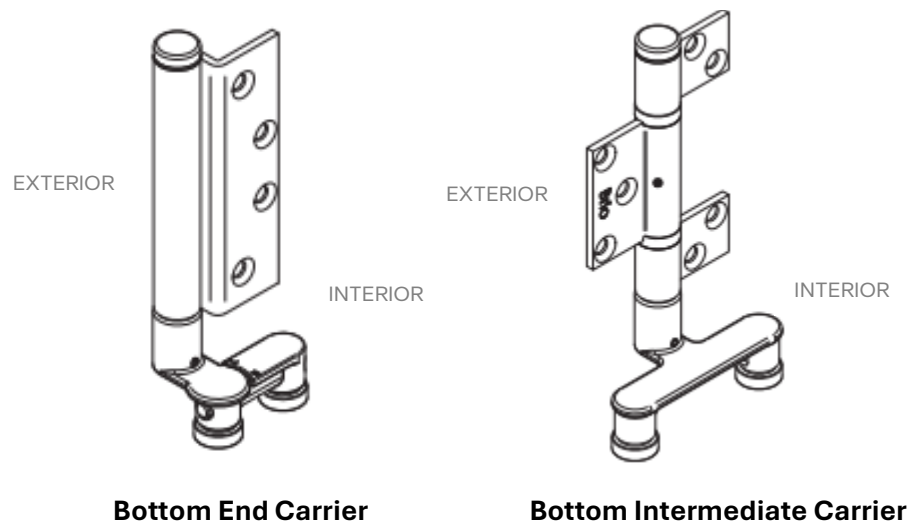

- K. Matching the carrier placement on the head of the unit, insert the bottom carriers in the sill track.

**When placing the bottom carriers in the sill track, ensure the hinge bolt is facing the exterior of the unit.**

# Jamb Pivot Information:

If the unit is 60" or taller there will be jamb pivot hardware. If the unit is below 60" in height, skip this section and proceed to the Panel Installation section of the instructions.

If applicable, there are two main parts of the Jamb Pivot hardware – the jamb mount assembly and the hinge assembly. The jamb mount will be applied to the jamb(s), while the hinge assembly will be mounted to the pivot panel(s).

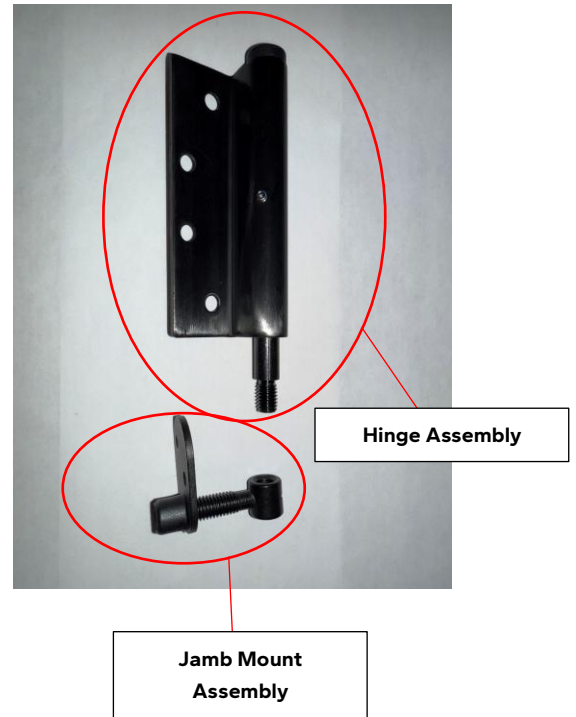
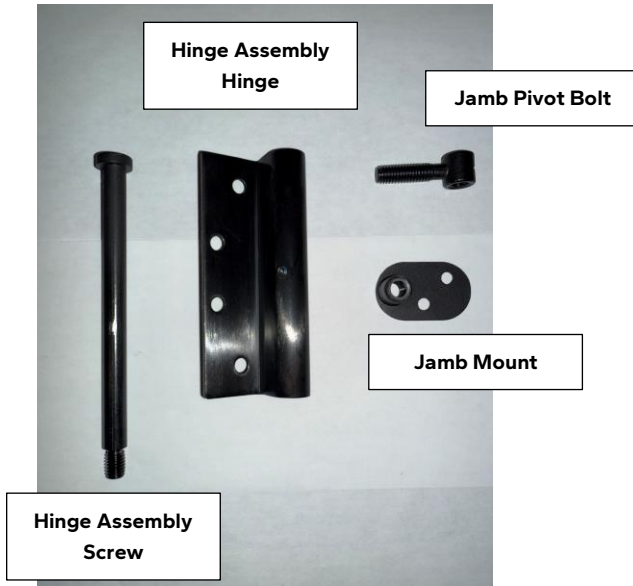

- A. **On the stacking side jamb(s), there will be pre-drilled holes located towards the middle of the jamb.** Install the jamb mount into this hole using the provided jamb pivot bolt and screws to secure in place.

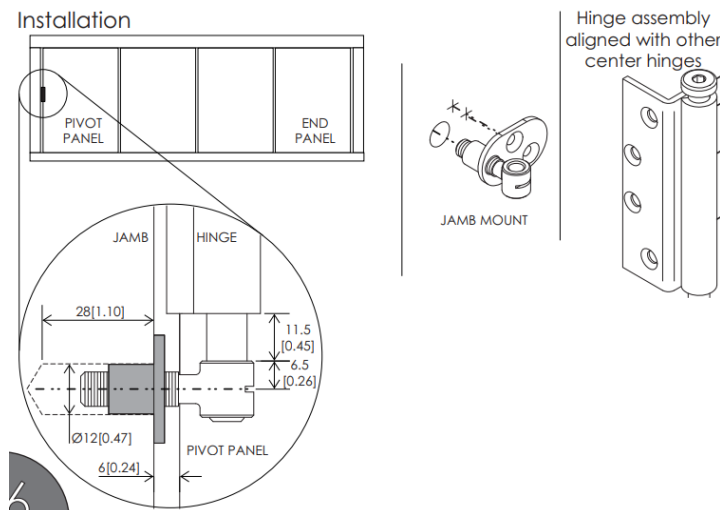

## Jamb Pivot Information (continued):

- B. **Once the jamb mount assembly has been mounted to the jamb, locate the pivot panel(s).** Begin pulling out the #10-32-3/4 screws that are sticking out approximately 1/4"-1/8" out of the panel in the middle hinge location, leaving the top and bottom hinge location screws as is.

Once the screws have been removed from the middle hinge location, line up the jamb pivot hinge assembly with the pre-drilled holes. Using the #10-32-3/4 screws that were just removed from the panel, secure the jamb pivot hinge to the pivot panel.

Once the jamb mount assembly has been secured to the jamb and the hinge assembly to the pivot panel, proceed to the [Panel Installation](#) section of the instructions. The remaining steps for the jamb pivot hardware will be located in this section.

# 5 Panel Installation:

Identify and locate all panels for installation: pivot panel(s), lead panel(s) and the remaining panel(s) will be your intermediate panel(s). 2L-3R Example below

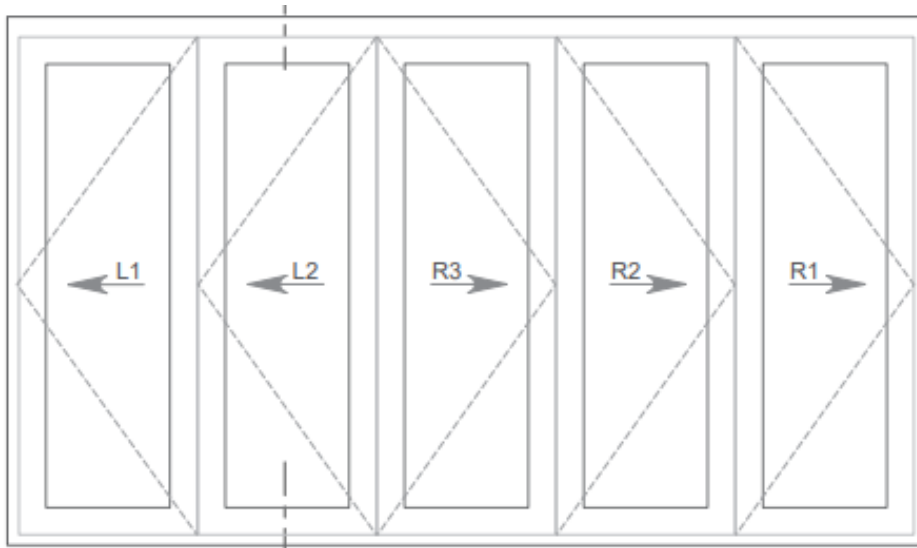

From Left to Right: Pivot Panel, Lead Panel, Lead Panel, Intermediate Panel, and Pivot Panel

Each panel will be alphabetically labeled to help configure which panels go where. Not always will the A panel be the first panel hung in the frame. The panel started with depends on what handing the door is.

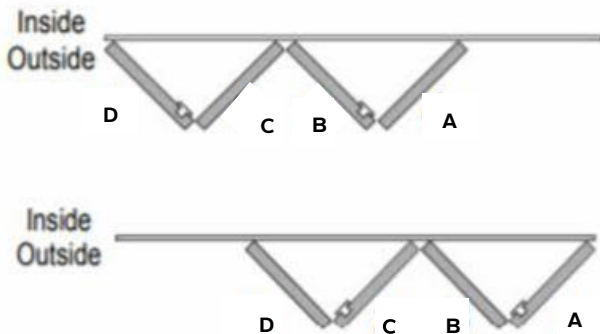

### NOTICE

- Panel labeling is always right to left (viewed from exterior)
- After the frame is installed per the instructions above, always start with the pivot side first.
- Do not open the hardware boxes arbitrarily to prevent mixing hardware up.

## 5 Panel Installation (continued):

Each panel comes with Philips head #10-32-3/4" alignment screws in the top, middle and bottom hinge locations used to mount the carrier hardware and connect the panels. These screws must be removed prior to installing the hardware on each panel. To avoid any misplacement of screws, it is recommended to only remove the screws on the panel that is being hung, do not remove the screws on all panels at the same time.

There will also be screws that are flush with the panel in the top and bottom hinge locations – two at the top hinge location and two at the bottom hinge location, four total flush screws per panel. **DO NOT** remove these screws. Only remove the screws that are sticking out of the panel at each hinge location. In below graphic, screws circled in red need to be removed and the two screws that are not circled, will **NOT** be removed and remain in the panel.



Additionally, there will be hinges already installed on the panel(s) depending on configuration. **DO NOT** remove these hinges, the hinges have been placed during manufacturing to aid with the panel installation and will be used to connect the panels together throughout this section.

## 5 Panel Installation (continued):

**NOTICE** To make installing the panels easier, it's suggested to use some shim material to set the panels on while installing each panel.

- A. **Starting at the top hinge location of the pivot panel, begin pulling out the screws that are sticking out approximately 1/4"-1/8" of the panel.** Once the top hinge screws have been removed, begin removing the remaining screws in the middle hinge (if applicable) and bottom hinge locations.
- B. **Continuing with the pivot panel,** anchor the panel to the top pivot hinge through the predrilled holes with the supplied #10-32-3/4" hinge screws that we're removed from the panels.

**TIP – When attaching the hinges to the panels, always install the hinge screws which are closest to the edge of the panel first.**

**NOTICE** When securing the hinges to the panels, ensure that you are driving screws through the countersunk side of the hinge, with the flush side of the hinge in contact with the panel. This will allow for the screws to be flush with the hinge.



Countersunk Side



Flush Side

- C. **Once the top pivot hinge has been secured to the panel, move down to the jamb pivot hinge (if applicable).** If the unit doesn't have jamb pivot hardware, skip this step and proceed to [Step D](#) in the [Panel Installation](#) section.

Line up the hinge assembly screw with the hole in the pivot bolt. Once lined up, tighten the hinge assembly screw to secure the jamb hinge assembly to the jamb mount.

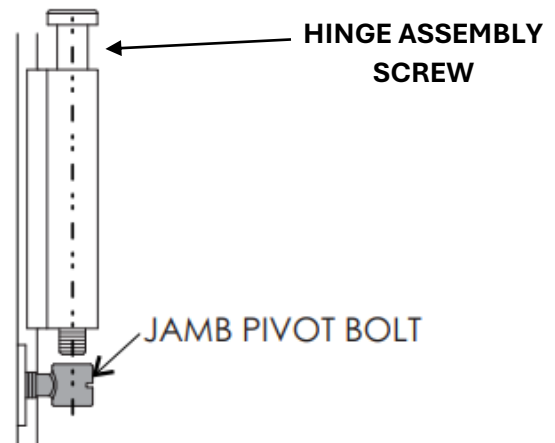
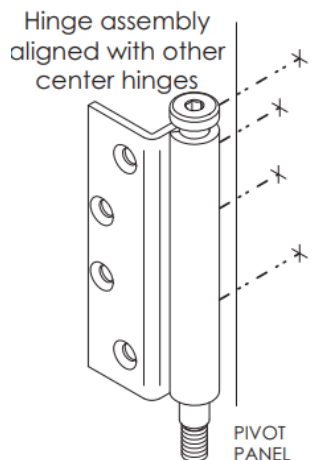

## 5 Panel Installation (continued):

- D. **Keeping the panel perpendicular to the frame**, use the remaining #10-32-3/4" hinge screws, anchor the panel to the bottom pivot hinge through the predrilled holes.

**NOTICE** Once the pivot panel has been hung, ensure that there is a 0.24" gap between the pivot panel and the jamb. If the gap is too large or too small, please refer to the [Panel Adjustment](#) section of the instructions.

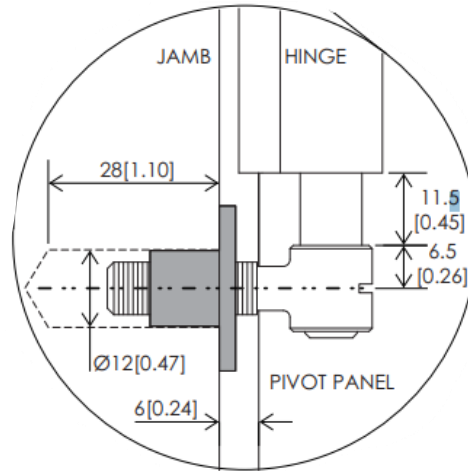

- E. **Once the pivot panel has been hung**, identify the next panel in the sequence. Set the second panel to be installed, face to face with the first panel. Mirror the panels, interior to interior in a fully opened position.
- F. **One of these panels will have the top, middle, and bottom hinge hardware pre-installed.** Do not remove the hinges from this panel. Instead remove the hinge screws sticking 1/4" to 1/8" out of the other panel, similarly to the pivot panel.
- G. **Using the provided hinge screws that were just removed from the panel**, mount the hinges on the panel, connecting the two panels.
- H. **Position the carrier sets next in the sequence next to the second panel** and remove the screws sticking out of the panel in the top, middle, and bottom locations. Mount the carrier hardware and middle hinge (if applicable) to the second panel.
- I. **Continue hanging the panels** with the corresponding hinge sets until all panels have been hung.

## 6 Panel Adjustments:

Once the panels are set, look at the reveals and adjust the panels if needed.

Before adjusting panels up/down, ensure that the frame is plumb and level within 1/8".

Before adjusting panels side-to-side, ensure there is a 0.24" gap between the pivot panel(s) and the jamb in the closed position.

**A. Completely shut the entire door.** Check the jamb reveal on the pivot side. Center the group of panels in the frame. Take a look at the top head to the panel reveals. This should be set just right if not extremely close. There should be an even space the length of it, with a slightly larger gap in the middle due to the crowning of the head.

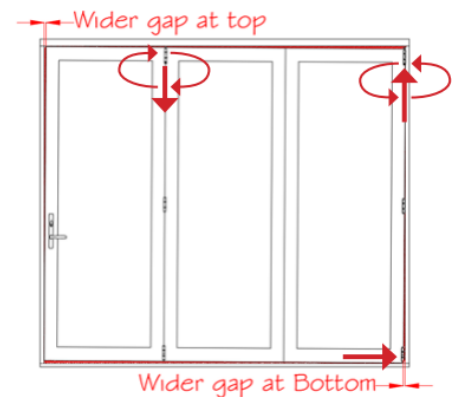
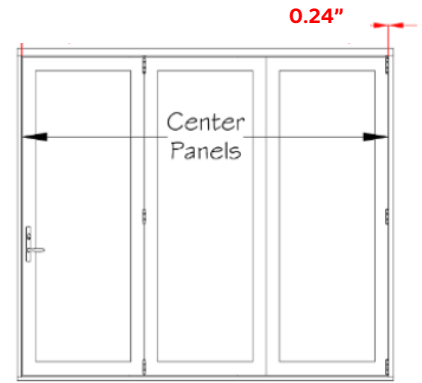

**B. If the head reveal is off,** raise or lower a carrier roller or pivot and/or adjust the 2 pivot side-to-side adjustments

Up/down adjustments can be made with using an Allen Key that was provided in the hardware boxes.

Before adjusting the hardware, ensure that the depress button on the carriers has been engaged to allow for adjustment.

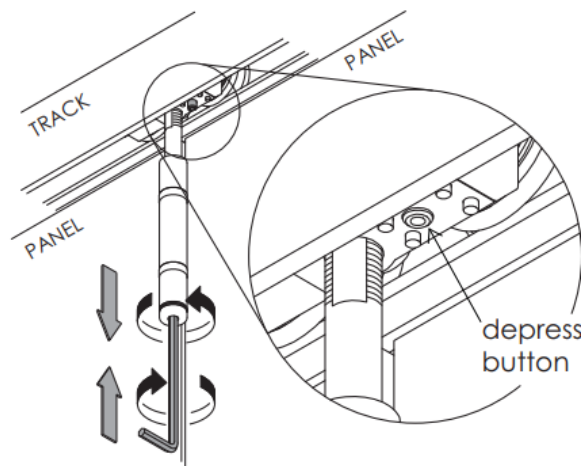

**NOTICE** To assist with up/down adjustments, ensure the panels are in the open position.

## 6 Panel Adjustments (continued):

- C. The most important reveal is the pivot side. An optimal gap would be 0.24".

**IMPORTANT NOTICE** To make side-to-side adjustments, the pivot panel(s) must be removed prior to adjusting the jamb pivot and/or pivot carrier hardware. Not doing so may result in hardware breakage.

- D. **Remove the pivot panel(s) from the unit and set aside.** To remove the pivot panel, remove all hinge screws on the jamb side of the pivot panel and set aside. If applicable, the pivot panel can remain attached to the other panels in the sequence, while remaining detached from the pivot carriers.

**NOTICE DO NOT** set pivot panel(s) against the unit, this may cause damage on the glass, frame and/or panels. If the pivot panel is still attached to other panels in the sequence, it is recommended to have someone aid by holding this panel while adjustments are being made.

- E. **Once the pivot panel has been removed, adjust pivot and jamb carrier hardware.**

### TOP PIVOT:

Remove the top pivot carrier cover and set aside. Once removed, engage the depress button on carrier and loosen the locking screws. Using an Allen Key, adjust the top pivot hardware. Once adjustments have been completed, ensure that the hinge is in contact with jamb, tighten the locking screw, and secure top pivot cover.

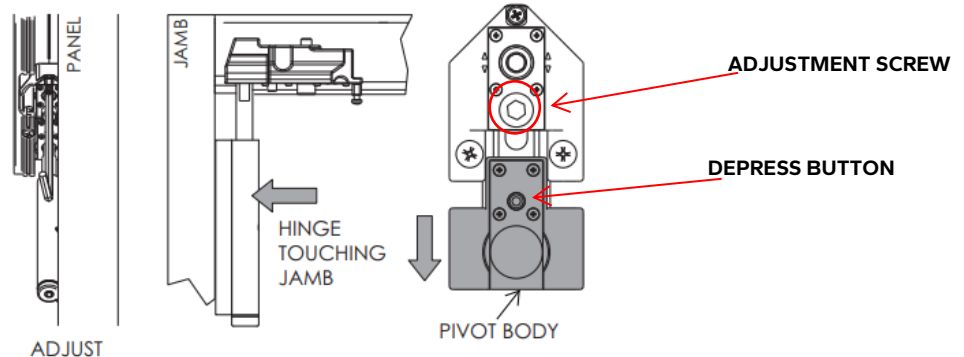

### JAMB PIVOT:

To adjust the jamb pivot hardware, tighten the jamb pivot bolt to decrease the reveal or loosen the jamb pivot bolt to increase the reveal. Once adjustments have been completed, ensure that the jamb pivot bolt is in the correct orientation so the hinge assembly screw can be re-inserted when the panel is re-installed.

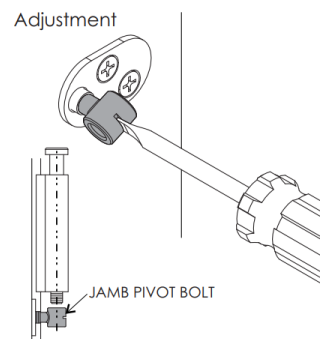

## 6 Panel Adjustments (continued):

### BOTTOM PIVOT:

To adjust the bottom pivot carrier hardware, loosen the two locking screws. Once the locking screws have been loosened, using an Allen Key adjust the position of the pivot towards or away from the jamb. Once adjustments have been completed, ensure the hinge is in contact with the jamb and tighten locking screws.

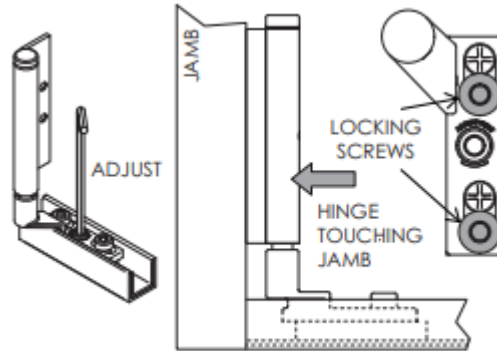

- F. After completing pivot carrier adjustments, reattach the pivot panel using the provided hinge screws.

## 7 Magnet Installation:

- A. Using the tool supplied in the magnet kit, unscrew and reveal the threaded back plate.



- B. Insert the provided screw through the hole on the back circular plate.



- C. On the primary lead panel, measure 1" from the outside and bottom edge of the panel.

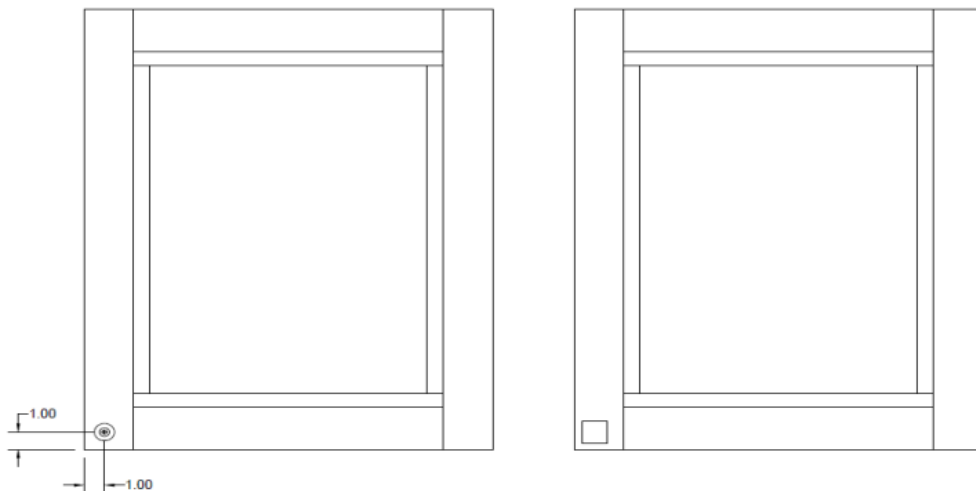

- D. Line up the circular plate and secure to the panel using the provided screw.

## 7 Magnet Installation:



E. Once the plate has been secured to the panel, install the magnet back onto the plate.



F. Repeat on the next panel in the sequence.



**NOTICE** The panel magnets are only required on the lead panel with the passage panel hardware (exterior handle), to prevent the handle from hitting the next panel in the sequence. However, magnets can be installed on all panels.

## 8 BIFOLD STUCCO KEY:

If ordered, the bifold stucco key will be pre-installed on the head and jambs of the unit. The stucco key on the jamb sections will extend past the jamb on the unit.

**WARNING** The bifold stucco key frame accessory is intended for aesthetic purposes **ONLY** and does not provide any structural support to the unit. **Ensure the unit is secured to the header through the pre-drilled holes in the head of the frame.**

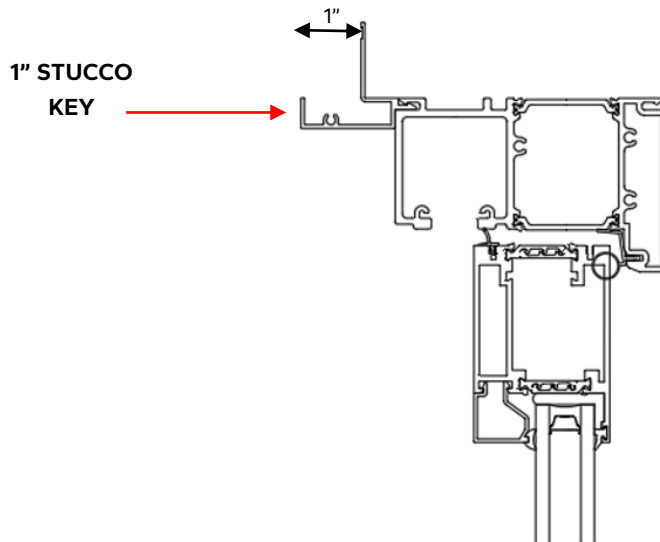

- A. Assemble the bifold frame per instructions – *Frame Assembly pg. 8.*
- B. Once the frame has been assembled, there will be two pre-drilled holes located at each end of the head. Ensure the pre-drilled holes on the head and jamb line up. Drive a #8 -1" screw through the pre-drilled holes. Ensure the screws are flush with the stucco accessory before proceeding.

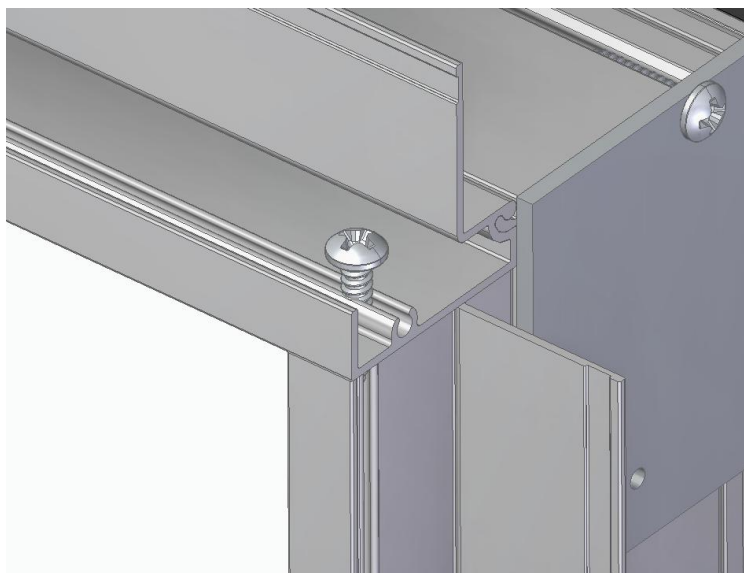

**Screw Location** – ensure this screw is flush before proceeding.

## 8 BIFOLD STUCCO KEY (continued):

- C. **Once the screws have been secured in the stucco accessory**, there will be two metal plates, one for each corner to fill the gap between the stucco accessory.

Apply sealant to the back side of the plate, where the double-sided tape is located. Ensuring that the sealant doesn't meet the tape. Apply the metal plate to both corners on the head of the unit.

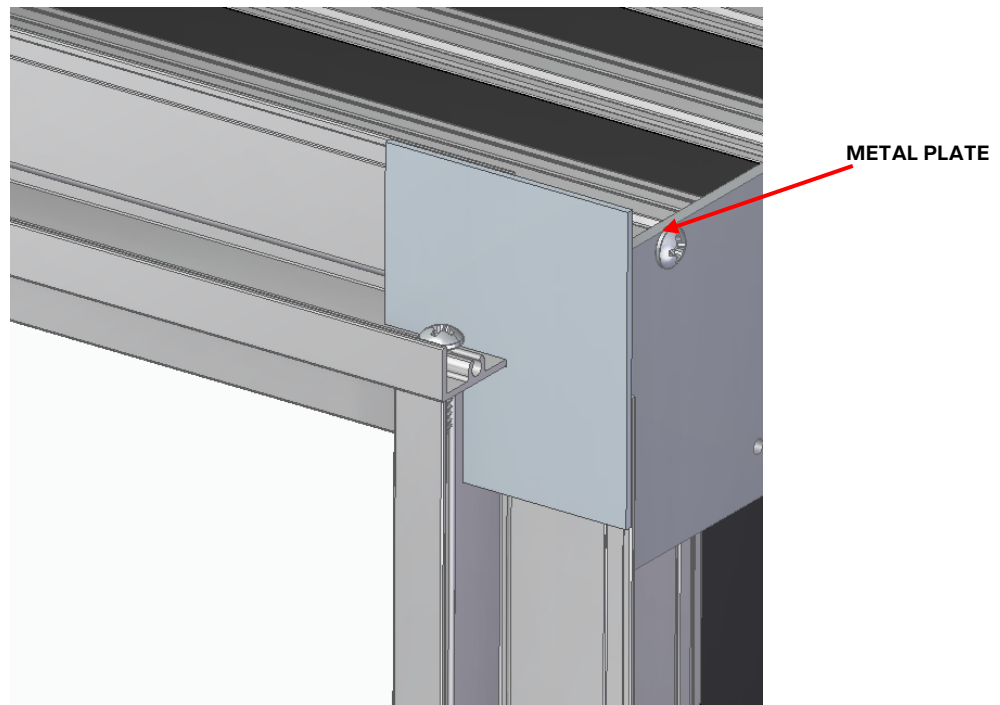

- D. **Once the corners have been secured**, apply a bead of sealant around the back perimeter of the stucco key accessory.

**Place three 3/8" beads of sealant across the opening sill.** Place the interior-most bead 1/2" from where the interior of the door sill will remain after installation. Continue this bead up the sill pan lip, if applicable.

**Place a second bead beginning from the interior** bead 1/2" from each side, out to the exterior of the framing and along the opening. Leave 2" voids 4" from the corner and at center. Place a third bead where the exterior of the door sill will remain after installation.

**Confirm** the sill is level, free of any crowns and sags.

**Center the bottom of the door in the opening** and tilt the door into position. Do not slide the door into the opening. Sliding will damage the sealant lines. Check the jambs for plumb and confirm there is room for shimming between the jambs and opening on each side. Confirm the sill is level.

- E. **Once the unit has been placed in the rough opening**, continue to [Step E](#) in the [Frame Installation](#) section.



# INTERIOR AND EXTERIOR SEALANT

## Interior Sealant Instructions

**CAUTION:** Continuous backer rod (as necessary) and a high quality, low-odor interior sealant is recommended for commercial or high performance installations to create the continuous interior seal. Follow the directions on the cartridge. For standard performance, use low pressure polyurethane insulating foams. Follow the directions on the can. Do not use high pressure or latex foams. Fiberglass batt or similar insulation is not recommended as it can absorb water and does not act as an air seal.

- A. **Insert the nozzle** or straw between the rough opening and door frame from the interior. Use pliers (if necessary) to compress the end of a straw tube to allow it to fit in tight openings.
- B. **Place a 1" deep bead of foam** approximately 1" from the interior of the frame to allow for expansion. DO NOT fill the entire depth of the rough opening cavity.

**NOTE:** Apply foam between the frame and rough opening, NOT between jamb extensions and the rough opening.

- C. **Re-check door operation** and remove remaining shipping spacers after foam installation. Excess foam may be removed with a serrated knife after it cures.
- D. **To ensure a continuous interior seal**, apply sealant over or around any shims or clips interrupting the foam seal.
- E. **Place a continuous bead of sealant** across the inner sill at the intersection of the door sill and subfloor. Continue the sealant 6" up each jamb.



## Exterior Sealant Instructions

**CAUTION:** Use a high quality, multi-purpose exterior. Follow the directions on the cartridge.

**When applying siding, brick veneer, flashing, or other exterior finish materials, leave adequate space between the door frame and the material for application of sealant.**

- A. **Insert backer rod 3/8" deep** in the space around the door. Backer rod adds shape and controls the depth of the sealant line.
- B. **Apply a continuous bead of sealant** to the entire perimeter of the door.
- C. **Shape, tool and clean excess sealant.** When finished, the sealant should be the shape of an hourglass

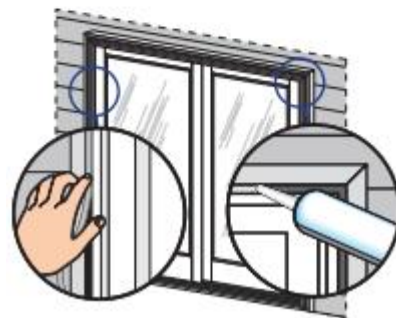



# OPTIONAL SILL PAN INSTRUCTIONS

**NOTICE** The method of pan construction, flashing, and sealant application may vary depending on the design of the opening sill and exterior landing surface conditions. It is important to consider exposure to weather, the exterior landing surfaces proximity to the door sill, and to confirm impervious exterior surfaces properly slope away from the door. Additionally, Sill pans are **NOT** included and will have to be provided by the installer if desired.

**A. Cut the sill pan** to the width of the rough opening plus 2".

**NOTE: The 2" added onto the rough opening width is for a 1" bend on each end.**

**B. Make 1" cut** in each fold at both ends of the sill pan.

**NOTE: These cuts will allow the edges of the sill pan to be bent.**

**C. Cut 1" off each end** of the interior sill pan lip.

**D. Bend each end** of the center panel up.

**E. Install the sill pan** by sliding into place until the exterior sill pan lip is flush with the exterior of the rough opening.

**F. Apply sill flashing tap.** Cut a piece of flashing tape 2" longer than the opening width. Apply at the bottom of the opening, covering the exterior sill pan lip as shown.

**NOTE: If applicable, apply spray adhesive to building felt prior to applying the flashing tape.**

**G. Cut a piece of flashing tape** to width of the opening. Install tape to the sill pan and overlap the flashing tape from step 1F by 1". If needed add a second or third piece of flashing tape until the sill pan is covered to the interior sill pan lip.

**NOTE: The purpose of this tape is to seal the sill screws when installing the door.**

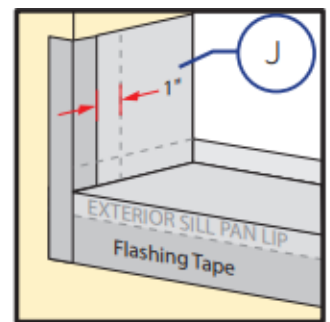
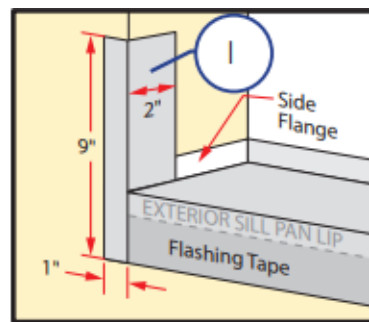
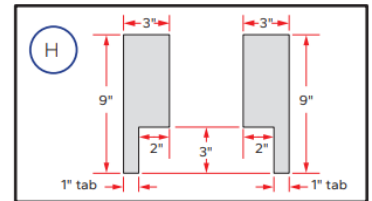
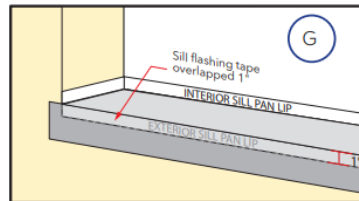
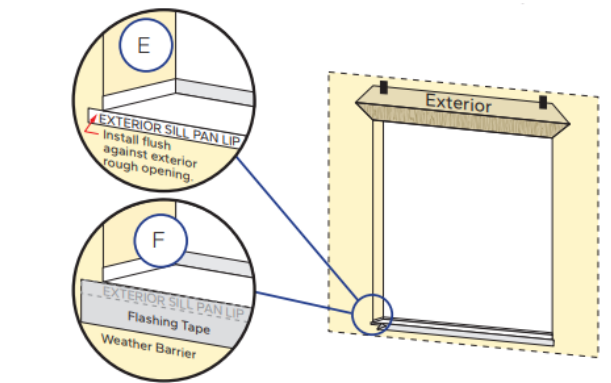
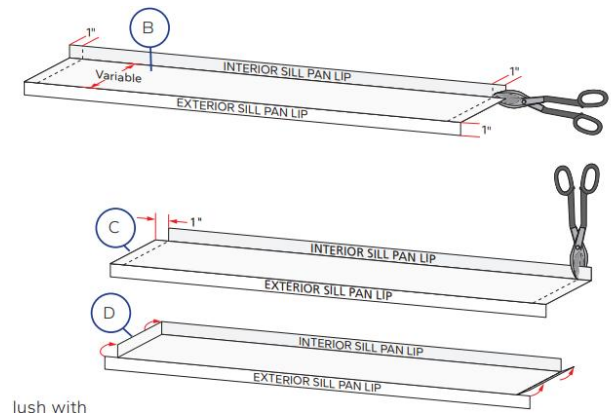

- H. **Cut two 9" pieces of flashing tape** with a 1" x 3" tab at the bottom, on the opposite corners as shown.
- I. **Apply the tabbed 9" pieces of flashing tape.** The tape is applied so 2" will cover the inside of the rough opening and lap over the side flange of the sill pan. The 1" x 3" tab laps over the bottom flashing tape as shown.
- J. **Cut two 6" pieces of flashing tape** and apply to each side of the rough opening, overlapping the first piece by 1" and lapping the bottom over the side flange of the sill pan as shown.
- K. **Cut two pieces of flashing tape 1-1/2" x 6"** and apply to the bottom corners of the opening by beginning in the corner of the sill pan, with 3/4" of the tape applied to the sill pan and 3/4" of the tape applied to the side flange. The remainder of the tape is to be at a 45 degree angle onto the exterior.
- L. **Attach the aluminum sill support** or wood blocking to the exterior of the box plate to support the edge of the door sill. Place the sill support flush with the subfloor

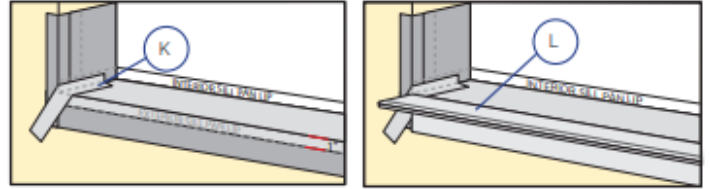

### Concrete Slab (without sill pan) Instructions

**NOTE: Thoroughly clean the slab where sealants will be installed. Instead of installing flashing tape across the bottom of the rough opening, complete the following:**

- A. **Install flashing tape at the bottom** 6" of the rough opening jambs.
- B. **Cut two 9" pieces** of flashing tape as shown in step 1H above.
- C. **Install them overlapping** the flashing tape installed in step A by 1".
- D. **Place a 3/8" bead of sealant** where the bottom edge of the flashing tape meets the concrete slab.
- E. **When folding building wrap in at the jambs**, cut at a 30 degree angle as illustrated.

Follow the applicable installation method pages to complete the installation except seal the door sill directly to the slab.

