



# BONELLI STACKING MULTI-SLIDE DOOR AND WINDOW INSTALLATION INSTRUCTIONS

---

## Contents:

Part/Tools .....	3
Product Safety Information.....	4
Care and Maintenance .....	5
Installation Information .....	6
Construction Sill Information .....	7
Opening Preparation .....	8
Frame Assembly / Installation.....	9
Spliced Units.....	17
Panel Installation .....	24
Keeper and Foam Placement.....	30
Multi-Slide Stucco Key .....	31
Panel Collector.....	33
Interior and Exterior Sealant .....	34
Sill Pan Instructions.....	35



## BEFORE BEGINNING FRAME ASSEMBLY AND INSTALLATION:

**Read through and understand all the assembly steps and the installation process.**

Carefully remove shipping/packaging materials and check for any product damage.

Confirm the correct product was received. (Size, color, handing, etc..)

If there are any parts missing, product damage, wrong parts, or other issues...



**DO NOT assemble! Contact Pella Customer Service at: 877-473-5527. Or Contact your local sales representative or customer service team.**

Before purchasing and installing, verify performance of product meets the requirements of the application and region. Not all products or sill types are rated for water performance. To reduce the likelihood of water infiltration where application exceeds product performance, install doors under an overhang that extends to meet a 45-degree line from the door sill and slope the exterior 2 degrees away from the door or use a stepdown.

**FAILURE TO DO SO MAY RESULT IN DAMAGE TO THE INTERIOR OF THE STRUCTURE.**

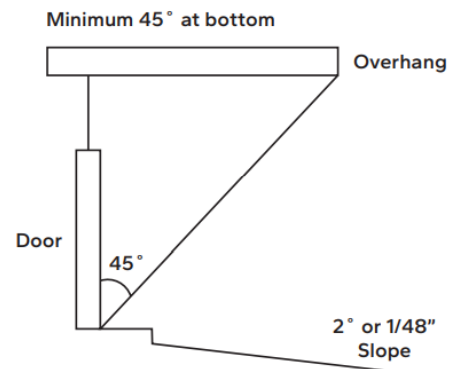

### Important Notices:

- Header must be designed to bear the weight of all building (roofing) and construction loads. Maximum allowable deflection of 1/8" over total span of the opening.
- Sill structure and framing must be designed and constructed to carry the weight of the door frame and door panels.



# STACKING MULTI-SLIDE SUPPLY LISTS

---

## Tools / Supplies (Not Provided):

- #2 Phillips handheld screwdriver
- Level
- Square
- Safety glasses
- Utility knife
- Wood block
- Tape measure
- Drill with 3/16" & 7/64" drill bits
- Drill with masonry bit for concrete applications
- Fine tooth miter saw
- Sealant gun with polyurethane sealant
- Speed square
- Laser Level (Recommended)
- Moisture resistant shims/spacers (12 to 20)
- Foil backed butyl window and door flashing tape
- Writing utensil (pencil, marker, etc.)
- Closed call foam backer rod/sealant backer (21 to 30 ft)
- High quality, multi-purpose window and door installation sealant
- Low expansion, low pressure polyurethane insulating window and door foam sealant. DO NOT use high pressure or latex foams
- Sill pan – Optional (Rough Opening Width +2)

## Supplies (Provided):

- Head/Sill end plate to jamb screws (#8 x 3/8" PH)
- Anchoring Screws (#10 x 2.5" PH)
- Masonry Plugs
- Fixed panel bracket and screws (#10 x 1 PH)
- Fixed panel interior screws (#8 x 1-1/4" FH drill tip)
- Lock keeper anchor screws (#10 x 3" FH)
- Head and sill foam plugs
- Bristle pads (required on single stacking doors only)
- Splice key – head/sill, one per track (on spliced frames only)



# IMPORTANT SAFETY AND PRODUCT INFORMATION

**Safety Alert Symbol Reference:** These symbols are intended to alert you to potential injury hazards and information. Obey all safety messages.



**WARNING** To ensure safety and security and help prevent property damage, including possible damage to your window or door, close and lock windows and doors any time they are not being used for venting on a nice day, and particularly during high winds or rain. Ensure all windows and doors are properly fastened to the wall structure according to the product anchor instructions. It is the responsibility of the Buyer or User, the architect, contractor, installer, or other construction professional to ensure the appropriate windows and doors are chosen for the project and the wall construction is designed to resist all loads in accordance with local building code requirements

**WARNING** Installation may require (2) or more persons for safety reasons.

**CAUTION** Many doors in older homes are painted with lead-based paint. Removal of old doors may disturb this paint. Proper precautions must be taken to minimize exposure to dust and debris. Consult state or local authorities and/or go to [www.epa.gov/lead](http://www.epa.gov/lead) for more information.

**NOTICE** Bonelli products must be stored in an upright, level position not exposed to weather. The storage must be ventilated and provide protection from direct sunlight and excessive temperature.

**IMPORTANT NOTICE** Because all construction must anticipate some water infiltration, it is important that the wall system be designed and constructed to properly manage moisture. Bonelli is not responsible for claims or damages caused by anticipated and unanticipated water infiltration; deficiencies in building design, construction and maintenance; failure to install Bonelli products in accordance with Bonelli's installation instructions; or the use of Bonelli products in wall systems which do not allow for proper management of moisture within the wall systems. The determination of the suitability of all building components, including the use of Bonelli products, as well as the design and installation of flashing and sealing systems are the responsibility of the Buyer or User, the architect, contractor, installer, or other construction professional and are not the responsibility of Bonelli.

Bonelli products should not be used in barrier wall systems which do not allow for proper management of moisture within the wall systems, such as barrier Exterior Insulation and Finish Systems (EIFS) (also known as synthetic stucco) or other non-water managed systems. Except in the states of California, New Mexico, Arizona, Nevada, Utah and Colorado, Bonelli makes no warranty of any kind on and assumes no responsibility for Bonelli windows and doors installed in barrier wall systems. In the states listed above, the installation of Bonelli Products in barrier wall or similar systems must be in accordance with Bonelli's installation instructions

Always read the Limited Warranty before purchasing or installing Bonelli products. BY PURCHASING, INSTALLING OR USING BONELLI PRODUCTS (INCLUDES BONELLI GOODS AND BONELLI SERVICES), YOU AGREED TO THE TERMS OF THE LIMITED WARRANTY AND YOU AND BONELLI and its subsidiaries AGREE TO ARBITRATE DISPUTES ARISING OUT OF OR RELATING TO BONELLI PRODUCTS, AND YOU WAIVE ANY RIGHT TO PARTICIPATE IN A CLASS ACTION RELATED TO BONELLI PRODUCTS unless you opt out of the Arbitration Agreement no later than ninety (90) calendar days from the date you purchased or otherwise took ownership of your Bonelli Products. Opting out of the Arbitration Agreement will not affect the coverage provided by any applicable limited warranty pertaining to your Bonelli products. To opt out, you must send notice by email to [info@bonelli.com](mailto:info@bonelli.com), with the subject line "Arbitration Opt Out". For complete information, including the full terms and conditions of this Arbitration Agreement, which are incorporated herein by reference, please visit [onelli.com/arbitration](http://onelli.com/arbitration) or email to [info@bonelli.com](mailto:info@bonelli.com) with the subject line: "Arbitration Details".



# CARE AND MAINTENANCE

---

**GLASS:** Remove any protective film and labels and clean the glass, using a soft, clean, grit-free cloth and mild soap or detergent. Be sure to remove all liquid by wiping dry or use a clean squeegee.

**NOTICE:** DO exercise special care when cleaning coated glass surfaces.

**NOTICE:** DO soak the glass surface with clean water and soap solution to loosen dirt.

**NOTICE:** DO use a mild, non-abrasive window cleaning solution.

**NOTICE:** DO dry all cleaning solutions from window gaskets, sealants and frames.

**NOTICE:** DO NOT use scrapers of any size or type for cleaning glass.

**NOTICE:** DO NOT apply any other types of film to the glass. Doing so could void product warranty.

**NOTICE:** DO NOT allow dirt and residue to remain on glass for an extended period of time.

**NOTICE:** DO NOT begin cleaning without rinsing excessive dirt and debris.

**NOTICE:** DO NOT use abrasive cleaning solutions or materials.

**NOTICE:** DO NOT allow metal parts of cleaning equipment to contact the glass.

**NOTICE:** DO NOT trap abrasive particles between the cleaning materials and the glass surface.

**NOTICE:** DO NOT lean any tools or materials against the glass surface.

**NOTICE:** DO NOT allow splashed materials to dry on the glass surface.

**NOTICE:** certain methods of interior shading, particularly the use of tinted films applied directly to the glass can generate excessive heat concentration within the insulating unit and thus lead to premature failure, not covered by glass warranty.

**FRAME:** Excessive debris in the sill can impede the operation of the unit. To maintain the sill track and operation, use the crevice attachment of the vacuum to remove debris. Additionally, ensure weep holes are free of debris at all times to allow for proper drainage.

**NOTICE:** The aluminum surfaces of the doors are finished either by means of powder coat painting process, or by an "anodizing" process. In either case, abrasive or caustic cleaners, including paint removers and abrasive materials, such as steel wool, should not be used to remove dirt or debris from these surfaces. Generally, the same cleaning parameters suggested above with regard to insulating glass are also appropriate here.

**HARDWARE:** Hardware is subject to deterioration from everyday use, it is recommended to carry out routine maintenance on all hardware to ensure proper operation.

**NOTICE:** To help prevent surface corrosion, wash all hardware with soap or mild detergent and warm water followed by rinsing with clean cold water and wipe dry.

**NOTICE:** In coastal or marine environments, it is recommended to apply a light application of corrosion preventative to hardware surfaces and using a dry cloth to remove excess. When using lubricant or corrosion protection compounds, be careful to avoid the adjacent surfaces and always follow the manufacturer's instructions (Applies to Hanger/Pivots, Guides, and Hinges).



# INSTALLATION INSTRUCTIONS FOR TYPICAL WOOD FRAME CONSTRUCTION

**NOTICE:** Header must be designed to bear the weight of all building (roofing) and construction loads. Maximum allowable deflection of 1/8" over total span of the opening

**NOTICE:** Sill structure and framing must be designed and constructed to carry the weight of the door frame and door panels.

## Installation Instructions for Typical Wood Frame Construction:

These instructions were developed and tested for use with typical wood frame wall construction in a wall system designed to manage water. These instructions are not to be used with any other construction method.

Building designs, construction methods, building materials, and site conditions unique to your project may require an installation method different from these instructions and additional care. Determining the appropriate installation method is the responsibility of you, your architect, or construction professional.

**NOTICE:** With multiple tracks it's very important to make sure the threshold is level the entire length of the opening and the distance from the interior to exterior.

**NOTICE:** Rough opening sill must be within 1/8" of being level before proceeding with installation.

**NOTICE:** FAILURE TO PROVIDE ADEQUATE ROUGH OPENING SILL PROTECTION FOR WOOD THRESHOLDS WILL VOID PRODUCT WARRANTY.

**NOTICE:** Proper steps must be taken when flashing and applying sealant to ensure proper waterproofing of the unit.

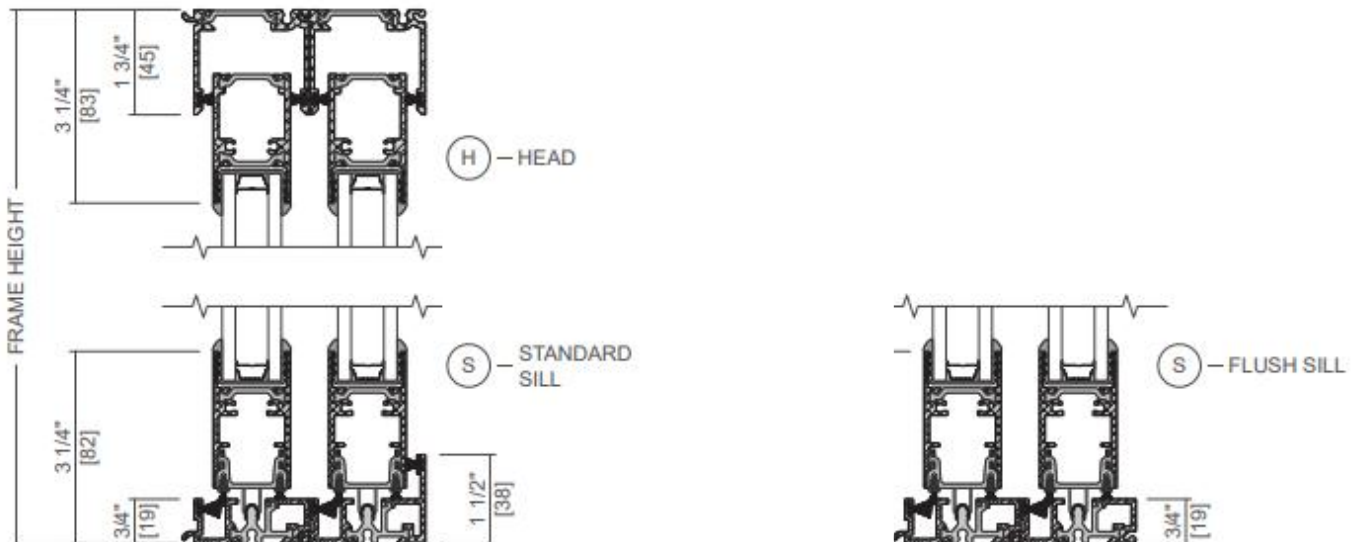



# CONSTRUCTION SILL COVER

---

The construction sill cover is a protective cover that snaps into the sill tracks to reduce the amount of dirt and debris getting into the track during the manufacturing, logistics, and installation processes as well as after installation on the jobsite.

During the installation process, the construction sill cover will need to be removed prior to assembling the frame and will remain out of unit through frame installation and panel installation.



**Without Construction Sill Cover**

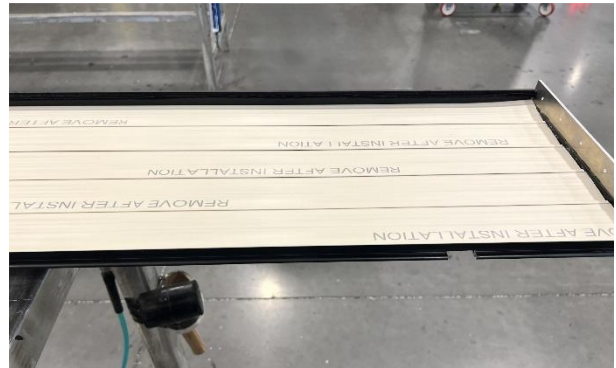

**With Construction Sill Cover**

Once the panels have been installed into the frame, the cover can be marked, cut to size and re-attached to the sill to protect the exterior tracks from dust and debris on the job site. After the job is complete, the cover will need to be removed entirely.

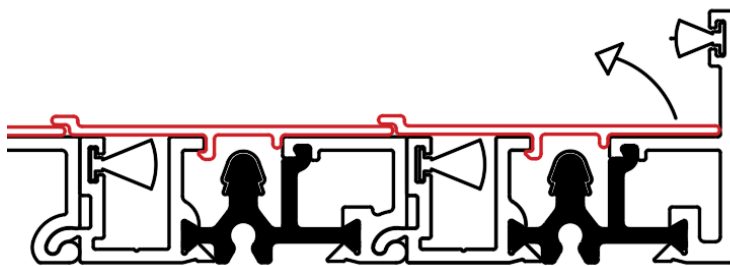

When removing the construction sill cover, begin at the innermost track. To prevent damage to the water sill weatherstrip. Carefully lift the interior part of the cover outward, moving continuously along its entire length. Avoid pulling the cover out from one side, as this can damage the weatherstrip

# 1 Opening Preparation:

- A. **Confirm the opening is plumb, level, and square.**

**NOTICE:** It is critical the subfloor is level and does not slope to the interior or exterior. The rough open sill must not vary more than 1/16" per foot and 1/8" overall, and must be plumb, level and square before proceeding.

- B. **Remove dirt, oil or debris** from the opening and surrounding wall surfaces.

- C. **Confirm the door will fit the opening.** Measure all four sides of the opening to make sure it is 1/2" to 3/4" larger than the door in both width and 1/2" larger in height. Measure the width and height in several places to ensure the header or studs are not bowed.

**NOTICE:** 1-1/2" or more of solid wood blocking is required around the perimeter of the opening. Fix any problems with the rough opening before proceeding.

**NOTICE:** It is important to consider the door's exposure to weather, the exterior landing surface type and its proximity to the door sill, and to confirm impervious exterior surfaces properly slope away from the door prior to continuing installation.

- D. **Cut the building wrap.**

- E. **Fold the building wrap in at the jambs and staple it in place.** Fold the top flap up and temporarily fasten with flashing tape

**NOTICE:** If using a sill pan or if the door will be installed on a concrete slab, refer to the instruction page at the end of this instruction. When installing on wooden subfloors, it is advised to utilize a sill pan.

- F. **Cut two pieces of flashing tape** 12" longer than the opening width.

- G. **Apply sill flashing tape #1** at the sill extending 1" to the exterior and 6" up each jamb.

- H. **Cut 1" wide tabs** at each corner by tearing the foil 1/2" each way from the corner.

- I. **Apply sill flashing tape #2** overlapping tape #1 by at least 1" by 1" minimum.

- J. **Continue applying additional pieces of flashing tape**, overlapping each previous piece by at least 1", until the entire depth of the sill is covered.

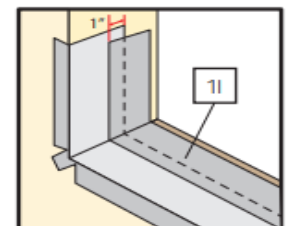
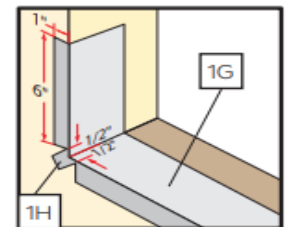
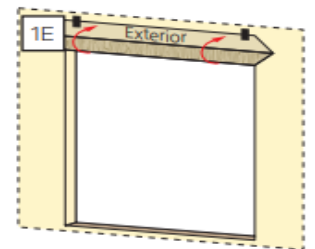
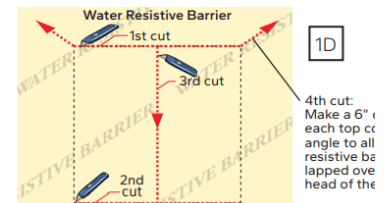

## 2 Frame Assembly:

**IMPORTANT NOTICE:** If your unit has a splice or is a corner unit, please refer to the Spliced Unit section on Pg. 17.

- A. **Unwrap packaged frame** and identify frame parts necessary (head, 2 jambs, and a sill). The sill type can be determined by referencing the cross-sections shown below (1-1/2" Standard and 3/4" Flush).

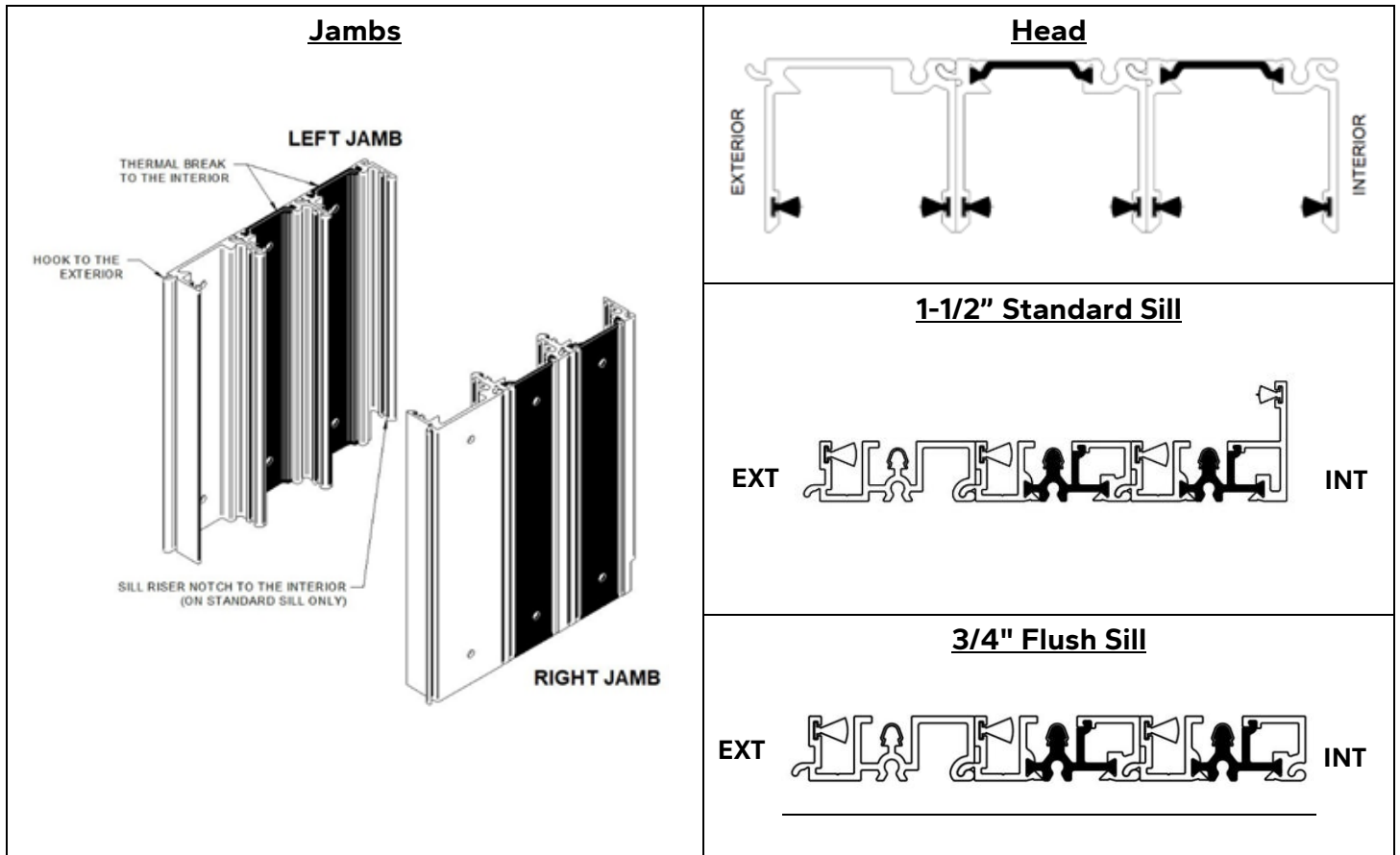
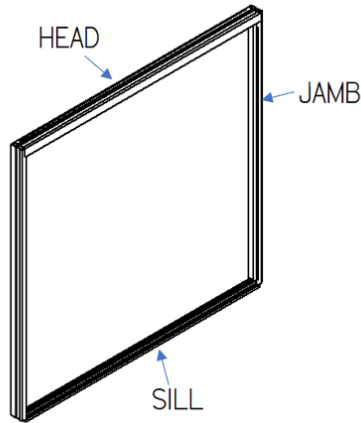

## 2 Frame Assembly (continued):

**NOTICE:** The holes in the head, jambs, and sill will be pre-drilled.

**NOTICE:** Use care if using an impact driver during the Frame Assembly Process. Impact drivers can cause screw head breakage.

**NOTICE:** Please refer to Page 32 for the Stucco Key installation process.

### SILL INSTALLATION:

- A. **Place the sill at the bottom of the rough opening.** Using a marker, trace the entire length of the interior edge of the sill onto the rough opening.

Next, trace the vertical lines (jamb sides) at each end of the sill.

Lastly, mark the pre-drilled anchor hole locations – these are found on the interior and exterior tracks (and the middle track if it's a five-track frame), and about 4" from each end and spaced evenly along the length of the sill.

**Helpful Tip:** Please refer to the below sill marking placement chart for additional information:

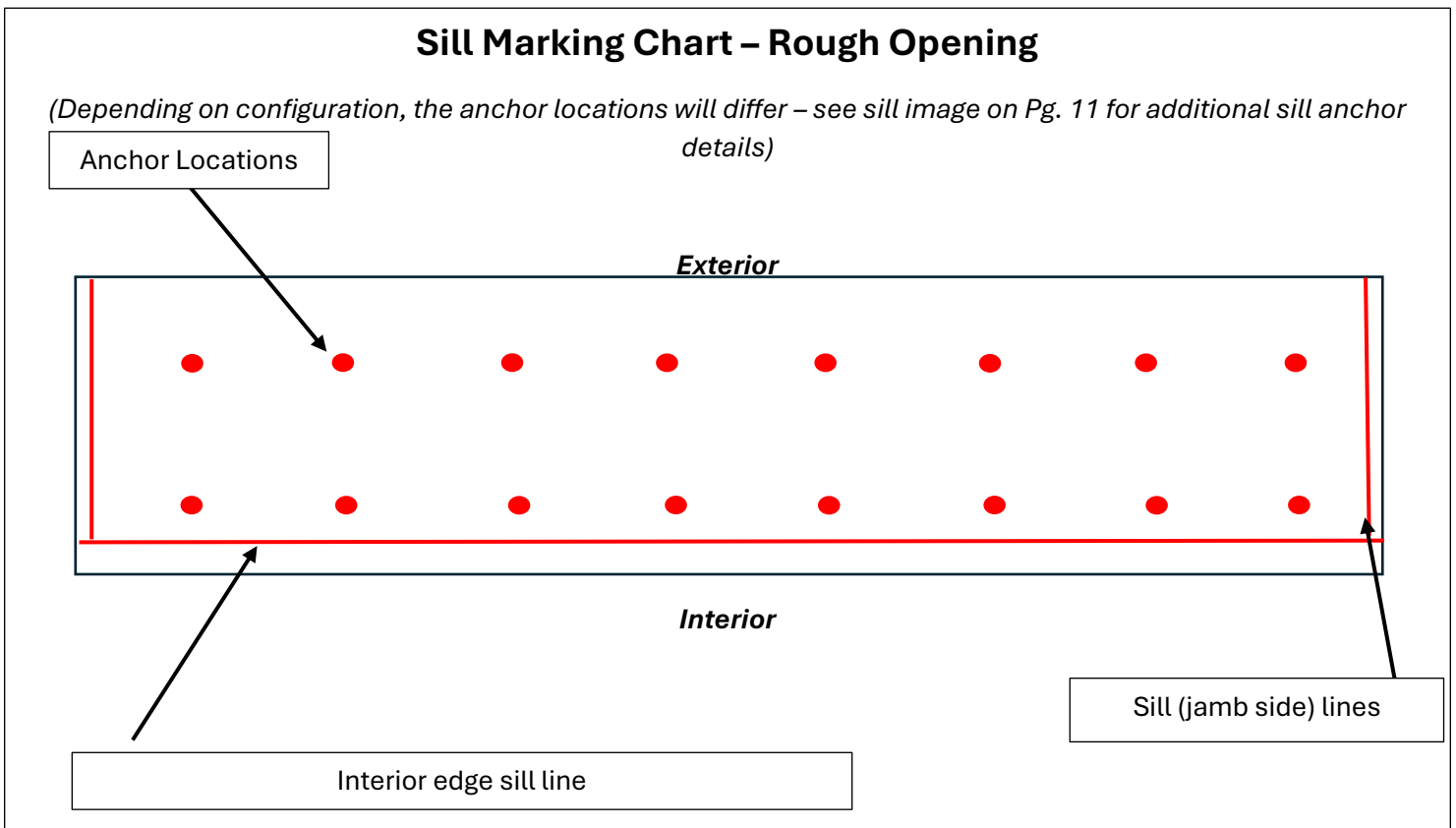

## 2 Frame Assembly (continued):

### Sill Anchor Locations

(Center screw location on five track frames only)

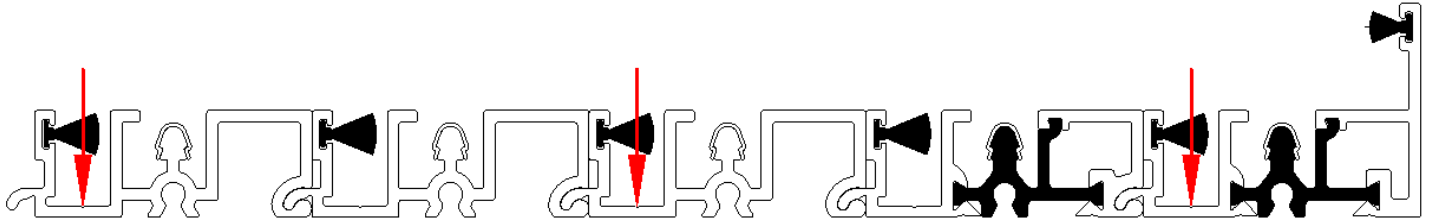

**B. Once the sill locations have been marked on the rough opening, remove the sill and set aside. Using a drill with #21-bit, pre-drill the sill anchor locations that were marked onto the rough opening.**

**NOTICE:** If the rough opening is concrete, use a masonry bit, pre-drill the anchor locations and install the provided anchor plugs at each location.

**E. Once all anchor locations have been pre-drilled, apply a continuous 3/8" bead of sealant as follows:**

- Starting on one side of the rough opening, follow the sill marking line drawn on previous steps.
- Extend the sealant 6" vertically up both jambs of the rough opening at each end of the sill and seal across the sill end marks (jamb side).



**F. Lastly, apply a dot of sealant at each pre-drilled anchor location.**

**NOTICE:** Ensure the sealant forms a continuous, unbroken seal across the entire sill area. Refer to the Sill Marking Chart – Rough Opening on the previous page for visual guidance specific to your configuration.

### 3 Frame Assembly (continued):

- C. **After the sealant has been placed on the rough opening**, realign the sill in the rough opening, ensuring the sill is centered and lines up with the pre-drilled holes.

**Once the sill has been placed**, walk across the sill to ensure proper contact with the sealant.

- D. **Shim as needed** between the end plate and the rough opening to prevent movement of the sill.

**NOTICE:** If the sill is shimmed, make sure the shims are spaced closely enough to minimize flexing and that the sill remains within 1/16" of level for every foot.

- E. **Secure the sill with the provided #10 x 1.5" anchor screws at each pre-drilled location.** Ensure the sill is within 1/8" tolerance of being level across the entire length of the sill and within 1/16" every foot be proceeding. Verify the sill is also plumb and square before proceeding.

### JAMB INSTALLATION

- A. **Locate and determine left and right jambs**, refer to the diagram on Pg. 9 for orientation.
- B. **Starting on one side of the sill**, apply a 3/8" bead of sealant from interior corner of the end plate extending across the depth of the sill, to the exterior corner of the end plate. Ensuring sealant comes in contact with the pre-drilled installation holes in the end plate.

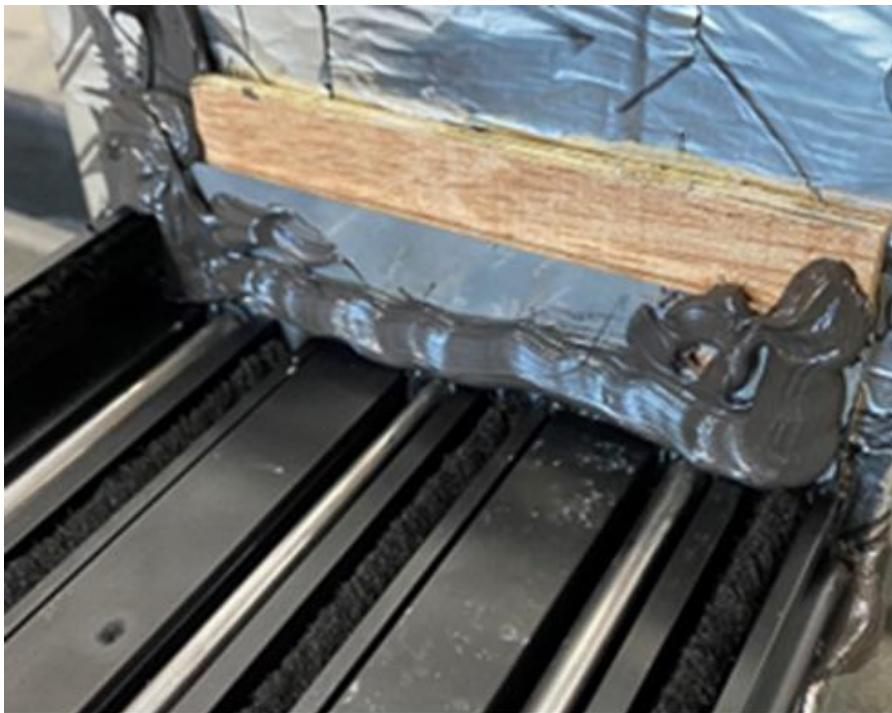

## 2 Frame Assembly (continued):

- C. **Once the sealant has been applied to the end plate**, set the appropriate jamb onto the sill edge. Align the bottom of the jamb with the end plate, then firmly press the jamb against the plate to ensure full contact with the sealant.

Before proceeding, verify the interior and exterior edges of the jamb are flush with the sill and plumb to the opening.

- D. **Once the jamb and sill are properly aligned**, secure the jamb to the sill by driving the provided #8 x 3/8" PH screws through the end plate. Clean any excess sealant.

- E. **Repeat step 2C-2E for the other jamb to sill connection.**

- F. **After the jambs has been secured through the end plate**, install the lower row of jamb anchor screws to hold the jamb in place for the remainder of the frame installation process. Larger units may require an additional row of anchors to hold the jamb in place.

**The jamb anchors don't need to be fully secured at this point.** The lower row of anchor screws main intent at this point in the installation process is to aid with holding the jamb piece in place while installing the head. Later in the installation process, we will pull these screws out and re-install with the appropriate amount of shims.

**HELPFUL TIP:** To aid with head installation it may be beneficial to stack shims or packaging foam towards the top of the jamb. This will hold the jamb away from the stud on each side and provide clearance for the jamb to head connection.

## 2 Frame Assembly (continued):

### HEAD INSTALLATION:

**NOTICE:** For larger units, and corner units a splice kit will be included. If a unit has a splice, please refer to the *Spliced Unit Section on Pg. 17* for additional steps

A. **Place the head of the frame in the rough opening**, ensuring the head end plates come in contact with the rough opening.

B. **Similar to the sill end plate sealant placement**, apply a 3/8" bead of sealant from interior corner of the end plate extending across the depth of the head, coming in contact with the head tracks, to the exterior corner of the end plate.

**Once the sealant has been placed**, remove any packaging foam and/or additional shims used to provide clearance for head installation, if applicable.

C. **Line up the jamb with the head** and firmly press the jamb against the plate to ensure full contact with the sealant. Clean any excess sealant. Add shims to the corners, behind the end plate as needed.

**Once the jamb and head are properly aligned**, secure the jamb to the head by driving screws through the end plate using the provided screws.

D. **Repeat step 2B-2C for the other jamb to head connection.**

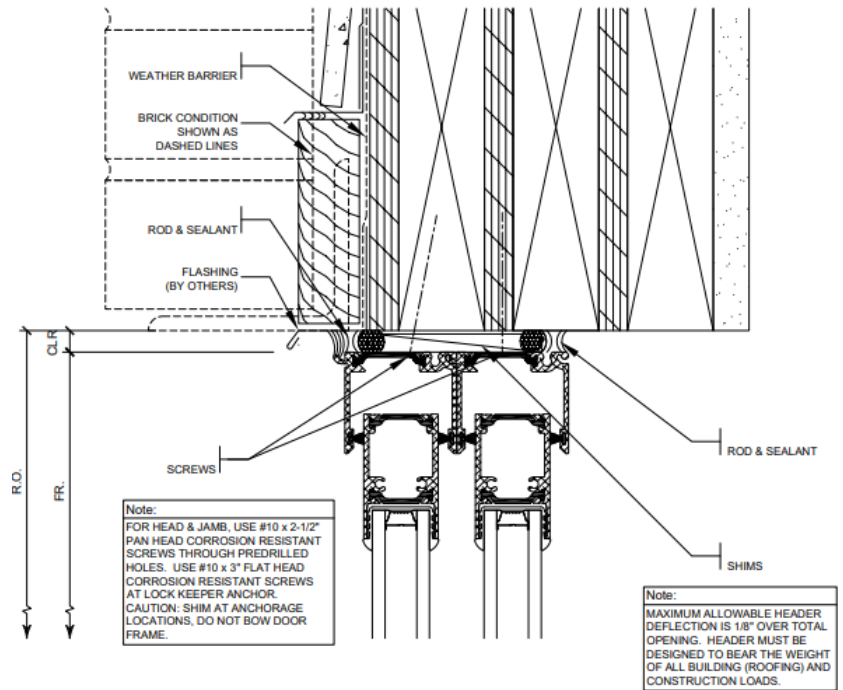

## 2 Frame Assembly (continued):

- E. **Once the head has been secured to the jambs**, remove the anchor screws used to hold the jamb in place during Step F in the Jamb Installation section. The bottom anchor screws will be re-installed with shims in the following steps.
- F. **On one jamb, starting at the sill**, insert and fasten an installation screw in each pre-drilled hole location with shim(s) between the frame and rough opening. Work up the jamb, checking with a level at every anchor location. Verify the jamb is within 1/8" of level the entire length of the jamb before proceeding.

G. **Repeat Step F for the other jamb.**

H. **Measure the frame diagonally** to confirm the frame is still square to the opening.

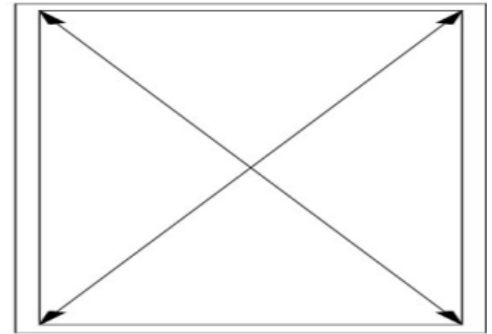

I. **Beginning near the center of the head**, shim and insert and fasten an installation screw at the pre-drilled hole location, checking the head.

J. **Finish installing the head frame screws and shims** in each pre-drilled hole location, checking with a level at every anchor location.

**HELPFUL TIP:** to assist with leveling the head, especially on larger units, consider using a gauge/guide board during installation. If using a guide board:

- a) On the exterior side, measure the frame opening height at each jamb.
- b) Cut a board (ex. 2 x 4) to match that measurement.
- c) Place the board on the sill and move it from one jamb to the other to verify consistent head height across the rough opening.

**NOTICE:** While checking, avoid dragging the board across the sill and head to prevent product damage.

- d) Once the board is cut to the correct length, begin at the center hole location and follow steps I & J. Move the board to each screw location during anchoring to ensure proper and consistent height. Confirm with a level before proceeding.

### 3 Spliced Unit Information:

Units exceeding a certain height and/or width along with Corner doors will require additional installation requirements. This section goes into detail about the additional steps needed to complete the installation for large units.

**NOTICE:** When installing spliced sill and head pieces, ensure there is less than 1/16" of separation where the splice locations meet.

**NOTICE:** Corner doors will always have two splice plates: the interior and exterior tracks. Stacking Multi-Slides will have a splice plate for every track.

**A. Line up the two sill pieces in the rough opening.**

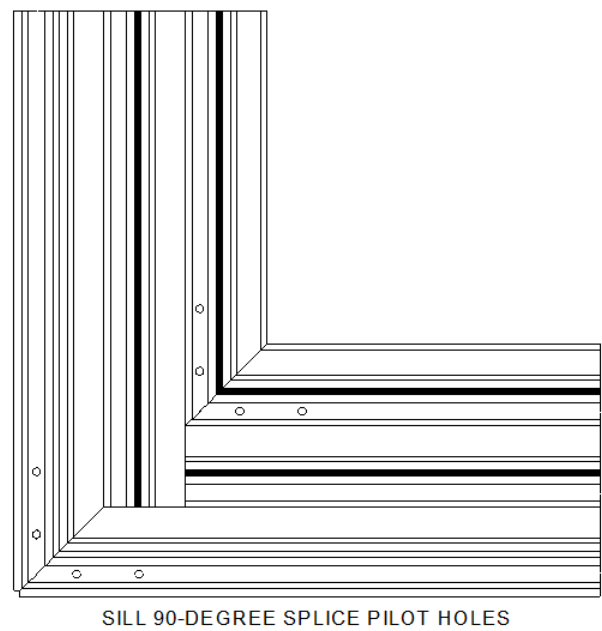
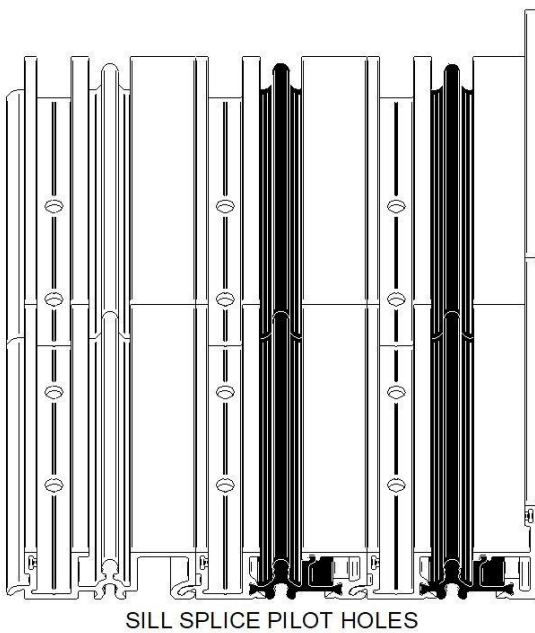

**B. Like Step A in the Sill Installation section on Pg.10, use a marker to trace the entire length of the interior edge of the sill onto the rough opening.**

**Next, trace the vertical lines (jamb sides) at each end of the sill.**

**Lastly, mark the pre-drilled anchor hole locations, including the spliced pre-drilled locations.**

### 3 Spliced Unit Information (continued):

- C. **Remove the sill pieces and set aside.** Using a drill with a #21 bit, pre-drill the anchor locations. Once complete, apply a 3/8" bead of sealant along the sill marking extending from jamb to jamb, extending the sealant 6" up both jambs of the rough opening. Finish applying sealant to the other marked locations.
- D. **Once the sealant has been applied,** realign the sill pieces in the rough opening and ensure the sill is centered and lines up at the splice locations. Apply a thin bead of sealant on the sill faces at the splice location.

Verify correct alignment with the provided splice plates.

**NOTICE:** For corner units, apply a continuous thin bead of sealant to the entire connection of the sill as shown in the figure below. Shape, tool, and clean excess sealant. See below for sealant location in red.

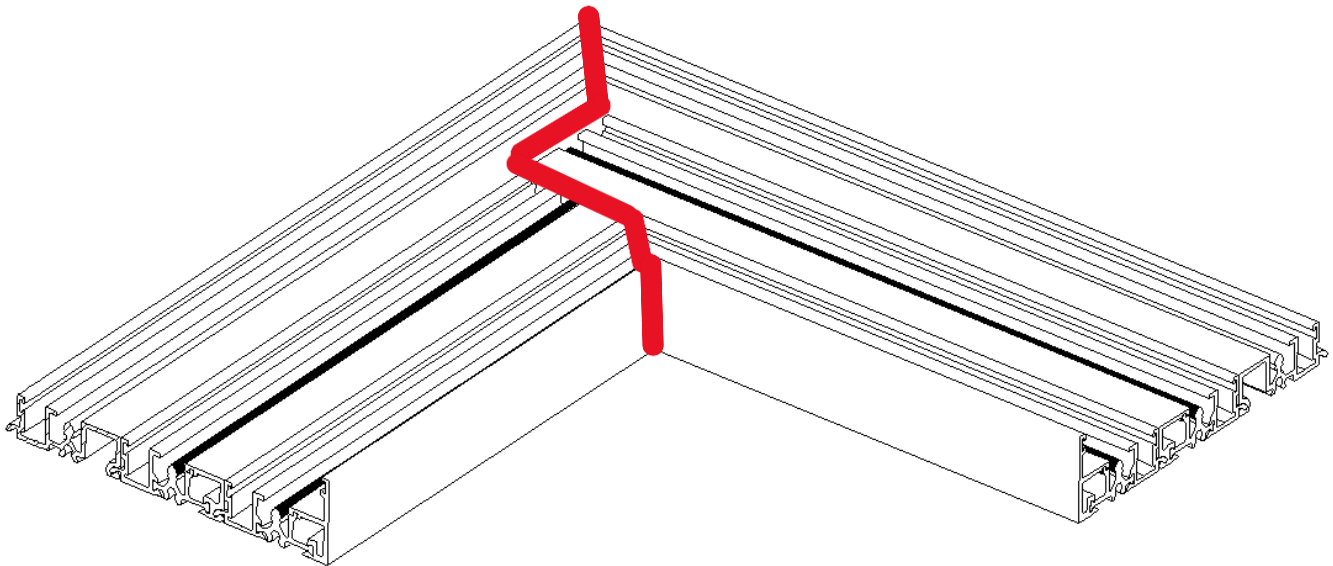

**NOTICE:** For Corner doors, it is important to ensure that the angle between the two sill sides is exactly 90 degrees – verify with an angle square.

### 3 Spliced Unit Information (continued):

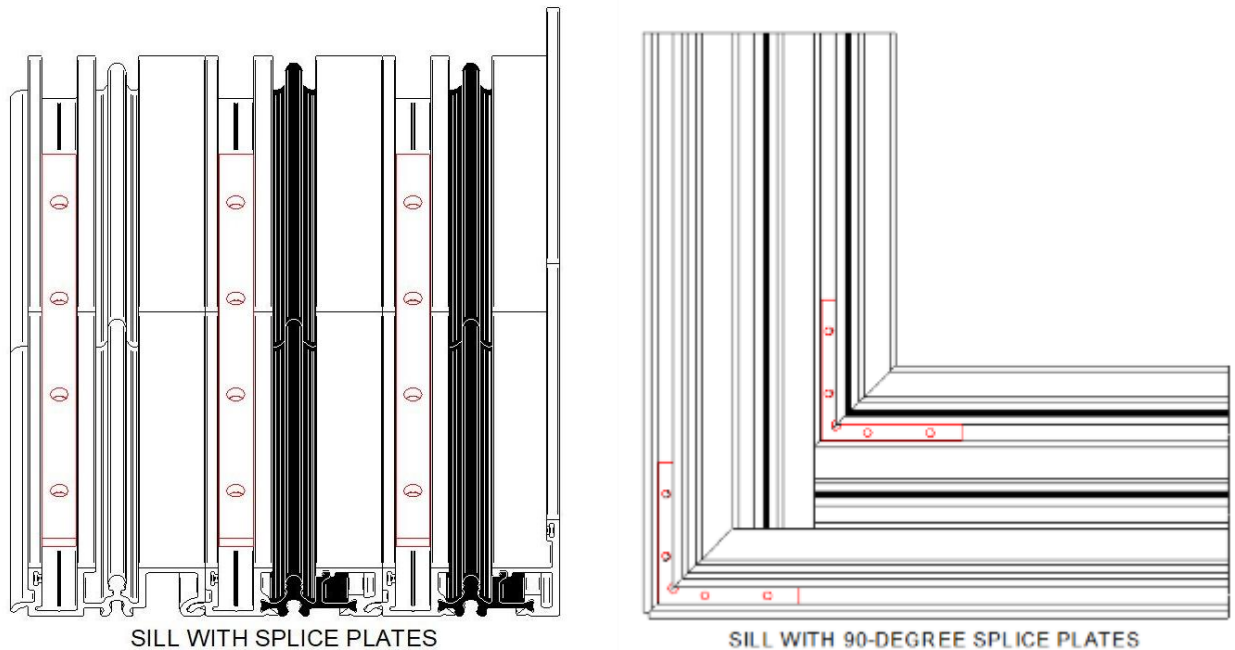

- E. **Specifically, for corner units, to ensure the two sill pieces are perfectly aligned** and on the same plane, place a level diagonally across the corner, spanning both sills.

**Carefully check that both sill pieces are level with each other**, ensuring they are even and aligned on the same horizontal plane. This step is crucial for proper installation and function of the unit.

- F. **Using the provided #10 x 1.5" anchor screws, begin anchoring the sill at the splice location**, through the pre-drilled holes in the splice plate, sill pieces and to the rough opening.

**Clean any excess sealant at the splice location.**

- G. **Finish securing the sill** through the remainder of the pre-drilled hole locations. Ensure the sill is within 1/8" tolerance of being level across the entire length of the sill and within 1/16" every foot before proceeding. Verify the sill is also plumb and square before proceeding.

**NOTICE:** To verify the sill is level, it is recommended to use a laser level.

### 3 Spliced Unit Information (continued):

- H. **Jamb installation will be the same as frames without a splice kit** – refer to the Jamb Installation section on Pg. 13.
- I. **Once the jambs have been installed, on the exterior side, measure the frame opening height** from the sill to header, at each jamb and cut two boards (ex 2 x 4). This will be used to hold the head pieces at the splice location as well as a guide to ensure the head is level. Once the boards are cut, set aside.
- J. **Place one of the head pieces in the rough opening**, ensuring the head end plate comes in contact with the rough opening. Apply a 3/8" bead of sealant from the interior corner of the end plate extending across the depth of the head, encountering the head tracks, to the exterior corner of the end plate.
- Once the sealant has been placed**, remove any packaging foam and/or additional shims used to provide clearance for head installation, if applicable.
- K. **Line up the jamb with the head end plate** and firmly press the jamb against the plate to ensure full contact with the sealant. Clean any excess sealant. Add shims to the corners, behind the end plate as needed.
- Once the jamb and head are properly aligned**, secure the jamb to the head by driving screws through the end plate using the provided screws.
- L. **Using one of the boards cut in Step H**, place the board at the edge of the head piece (splice location) to hold the head piece in place.
- M. **Leaving the first guide board in place**, holding the head piece, repeat steps I-L for the other head piece.
- N. **Once both head pieces have been secured through the end plate to the jamb**, leave the guide boards in place to aid with holding the head pieces in place while securing the splice plates.

Apply a thin bead of sealant on the head face at the splice location.

### 3 Spliced Unit Information (continued):

**NOTICE:** For corner units, apply a thin bead of sealant to the interior corner of the head. Shape, tool, and clean excess sealant. See below for sealant location in red.

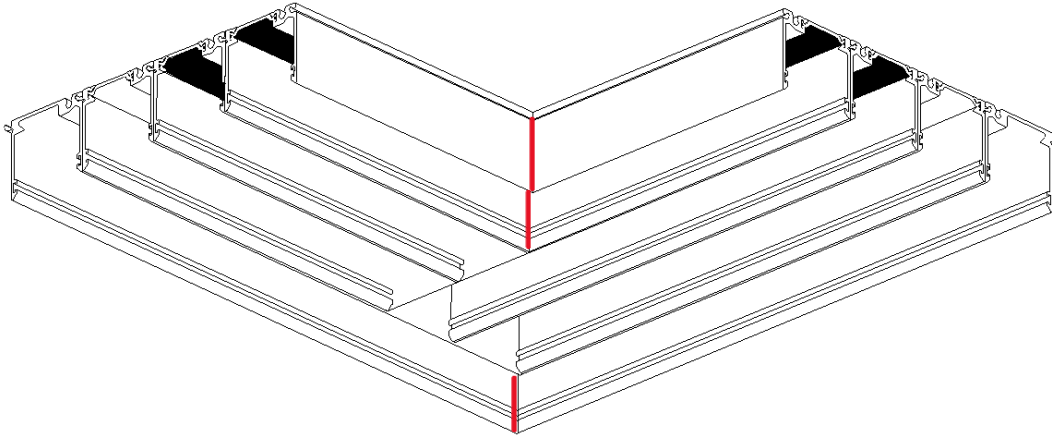

- O. **Once the sealant has been placed**, ensure head is plumb with the sill before proceeding.
- K. **Shim between the splice location and the rough opening.** Using the provided #10 x 1.5" anchor screws, begin anchoring the head at the splice location, through the pre-drilled holes in the splice plate, head pieces and to the rough opening.

Shape, tool, and clean excess sealant.

**NOTICE:** Ensure the interior and exterior corner points of the head are perfectly aligned with the corresponding sill corners. Use a laser level to verify precise alignment.

**NOTICE:** For corner units, it's important to ensure that the angle between the two head pieces is exactly 90 degrees, use an angle square prior to securing the head into the opening. Failure to do so may impact the door's operation and performance.

### 3 Spliced Unit Information (continued):

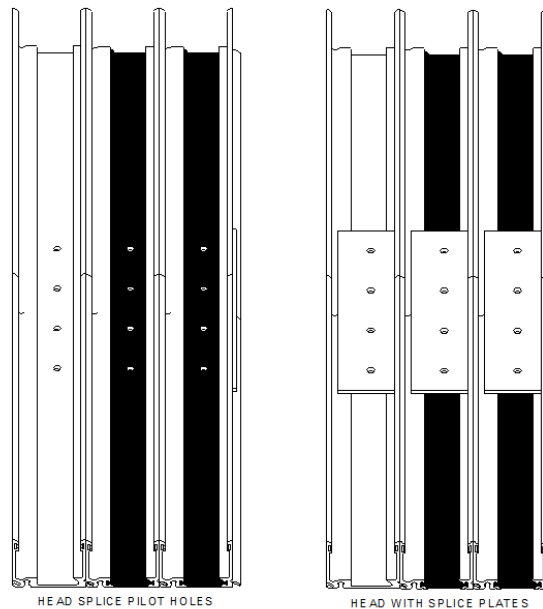

- P. **Once the head has been secured at the splice location**, remove the anchor screws used to hold the jamb in place during Step F in the Jamb Installation section. The bottom anchor screws will be re-installed with shims in the following steps.
- Q. **On one jamb, starting at the sill**, insert and fasten an installation screw in each pre-drilled hole location with shim(s) between the frame and rough opening as needed. Work up the jamb, checking with a level at every anchor location. Verify the jamb is within 1/8" of level the entire length of the jamb before proceeding.
- R. **Repeat Step F for the other jamb.**

### 3 Spliced Unit Information (continued):

- S. **Measure the frame diagonally** to confirm the frame is still square to the opening.

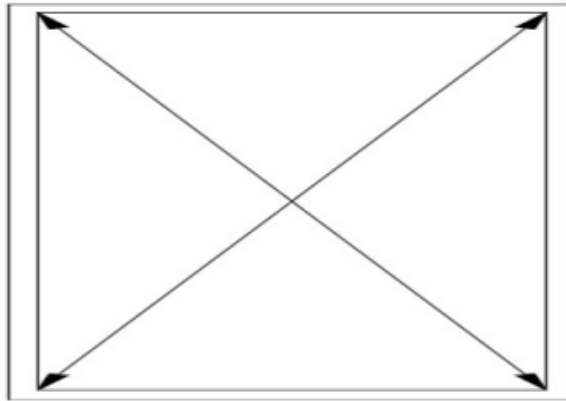

- T. **Beginning near the spliced section of the head, using one of the boards as a guide**, shim, insert and fasten an installation screw at a pre-drilled hole location. Continue installing head screws, checking the head height with the guide board at every location to ensure the head is level the entire duration.

Once all the head installation screws have been installed, verify with a level before proceeding.

**NOTICE:** For corner units, ensure that the head and sill on both sides of the corner are completely in plane with each other using a laser level or plumb device.

**IMPORTANT NOTICE:** It is very important to ensure the frame is plumb, level and square for spliced units. It is recommended to verify by using a laser level.

## 4 Panel Installation:

**NOTICE:** Before the panels are installed make sure all tracks are snapped securely in place. Use a block of wood and hammer and work down the entire length of the door's tracks. This will ensure the tracks are snapped into place which may have shifted during shipping.

### Vent-Panel Installation:

- A. **Identify the interior-most panel** (the panel onto which handle hardware is located) and from the exterior, insert the panel. Start by inserting the top of the panel into the interior-most head track and top the bottom of the panel into vertical alignment, ensuring the rollers are aligned with the track.

**Bi-parting units will have two interior-most panels.** One panel will include a lock, while the other will include the lock keeper.

- B. **Remove the roller adjustment hole plugs.** Using a Phillips screwdriver, raise the roller on each side of the panel, so the panel is ~1/4" above the track.

**HELPFUL TIP:** Lift one corner up to take the weight off the roller.

- C. **Slide the vent panel over to the lock side jamb** and inspect the gap between the jamb and the stile. Ensure the gap is consistent along the entire length of the jamb. Repeat this procedure by sliding the panel to the fixed side jamb to ensure uniformity.
- D. **Install the next intermediate panel** into the next track following the process as the first vent panel.
- E. **Repeat 4C-4D** on this panel and subsequent vent panels.

## 4 Panel Installation (continued):

- F. **Verify proper interlock engagement** between vent and intermediate panels. Move panels to a closed condition to allow the interlock to engage, then compare engagement at the top and bottom of the panels. If interlocks appear to be out of alignment, adjust panels as needed.

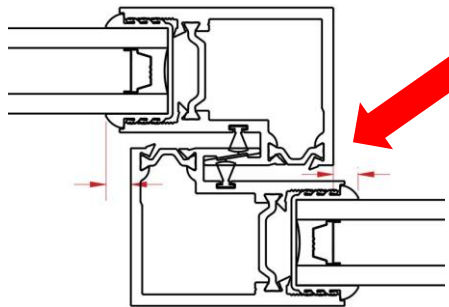

**Consistent  
Interlock  
Engagement**



- G. **Hold the locking vent panel and the 2<sup>nd</sup> vent panel together** and slide them as one. Check to see if the panels are sliding evenly together without shifting opposite of each other.

**For bi-parting units, treat each side of the bi-part as one unit,** checking the interlock engagement and panel operation of each side independently.

- H. **Follow steps 4E-4I** for subsequent vent panels.

## 4 Panel Installation (continued):

### Fixed-Panel Installation:

- I. **Identify the Fixed-Panel(s).** From the exterior, insert the panel. Start by inserting the top of the panel into the interior-most head track and top the bottom of the panel into vertical alignment, ensuring the rollers are aligned with the track.
- J. **Remove the roller adjustment hole plugs.** Using a Phillips screwdriver, raise the roller on each side of the panel, so the panel is ~3/16" above the track.
- K. **Slide the fixed panel over to the lock side jamb** and inspect the gap between the jamb and the stile. Ensure the gap is consistent along the entire length of the jamb. Repeat this procedure by sliding the panel to the fixed side jamb to ensure uniformity.

**IMPORTANT NOTICE:** DO NOT secure the fixed panel at this time.

- L. **After all the panels are in the unit, adjust the frame as necessary to get the acquired reveals.** Then, collectively check the reveals of every panel by sliding them together as one. Make sure the panels slide without shifting opposite the other panel or panels. Adjust the reveals as needed by shimming the frame. This is why the shimming process at the beginning is very important to minimize any reveal issues.

## 4 Panel Installation (continued):

### Sill Bristle Pad & Sill Channel Foam Plugs:

- A. **Locate the sill bristle pads, using the adhesive on the bottom of the bristle pad, install on the sill where the panels meet the lock side jamb and the fixed jamb.**
- B. **Once you have verified proper placement of the sill bristle pad, locate the sill channel foam plugs.**
- C. **With the panels in the fully closed position, mark each interlock location at the sill on the interior and exterior side.**
- D. **Move the panels to the open position and insert a sill channel foam plug into the sill channel at each location. The sill plug will extend approximately 1/4" past the interlock in both directions.**

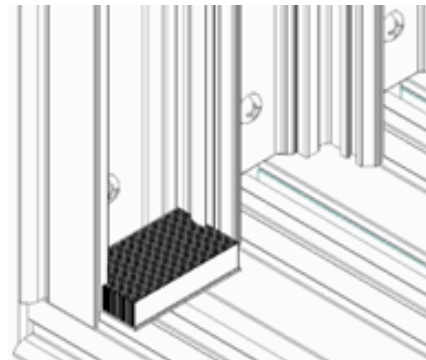

Sill Bristle Pad

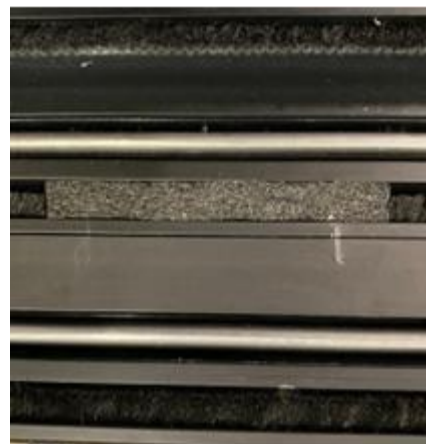

Sill Foam Plug

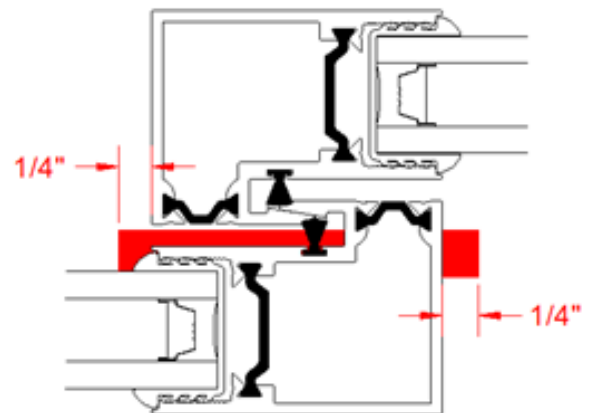
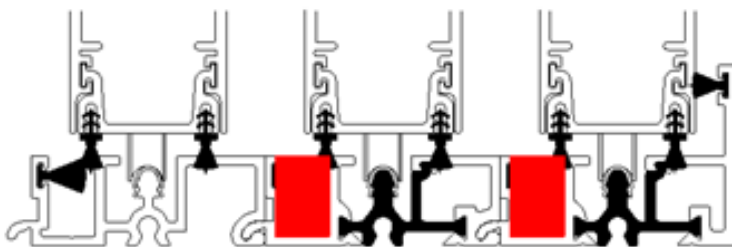

## 4 Panel Installation (continued):

**NOTICE:** Ensure all panel interlocks engage properly, and the weatherstrip on the bottom of the panel maintains contact with the sill. Make any final panel adjustment before securing the fixed panel.

E. Re-install the panel roller adjustment plugs before proceeding.

### Securing the Fixed-Panel:

- A. **Shut the door completely**, so the locking vent panel is completely in the jamb against the keeper, but the other panels are pushed back engaging the interlocks properly. Lock the vent panel.
- B. **On interlock side of the fixed panel, opposite of the jamb**, position the fixed panel bracket against the head and attach on the fixed panel using the provided screws.

**HELPFUL TIP:** Have a helper hold the panels in the closed position while anchoring the fixed panel to ensure there isn't any movement while securing the panel.

**NOTICE:** Ensure the fixed panel bracket is in the same position as the picture below.



- C. **Using the bracket holes as a guide**, pilot drill through the head of the frame and install an anchor screw into each hole into the rough opening.
- D. **For Bi-Parting units repeat Steps 6A-6C** on the other fixed panel.

## 4 Panel Installation (continued):

- E. **Once the bracket has been secured, on the interior side of the panel, drive the provided interior fixed panel drill-tip screws** through the frame and panel. These will be located approximately 6" from the bottom of the panel, the middle of the panel, and 6" from the top of the panel.

Do not overtighten the screws, it will cause the panel to go towards the interior.

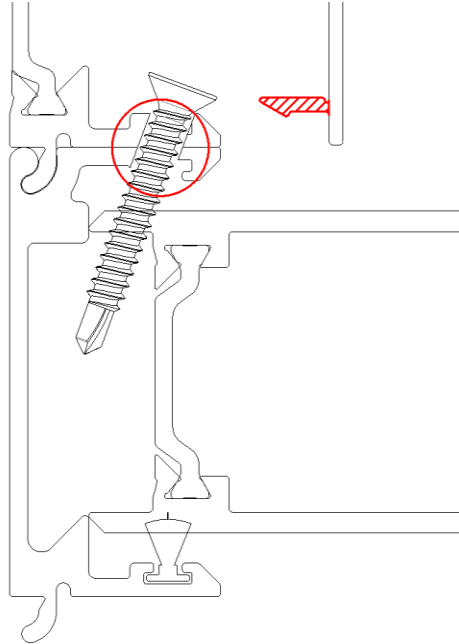

- F. **For bi-parting units, repeat this process on the other fixed panel.**
- G. **Once the fixed panel(s) has been secured, locate the jamb cover(s)**, the jamb cover with a notch on the corner will be the interior most jamb cover. These cover(s) will cover the frame installation screws making for a clean finish.
- H. **Starting with the interior most cover**, insert one end and apply pressure along the length of the cover to snap the cover into place.
- I. **If the bottom interior fixed panel screw does not fully seat into the jamb**, notch the jamb cover leg around the screw for clearance.
- J. Install the remainder of the jamb covers.

# 5 Keeper / Foam Installation:

## Keeper Installation:

If the door has a one-way stacking configuration, adjust and secure the lock keeper now.

The lock keeper will come pre-installed on the lock side jamb with short screws. Slide the panels into the closed position and operate the lock a few times to confirm it engages the keeper.

- A. **If the lock does not engage**, pull out the small, short screws, adjust the height of the keeper. Verify the lock engages. Through the pre-drilled holes, secure the keeper with the long keeper installation screws.
- B. **If the lock engages the keeper open the door**, pull out the small, short screws. Through the pre-drilled holes, secure the keeper with long keeper installation screws.

## Head Channel Foam Plugs:

- A. **Once the keeper has been secured**, identify the head foam plugs.
- B. **From the exterior of the head of the frame**, where the first and second panel meet, insert the foam plug in the channel in the head. Firmly press against the head track and panel to ensure the foam is seated properly.
- C. **Repeat process for all intermediate panels.** Head foam plugs are not required on the fixed panel.

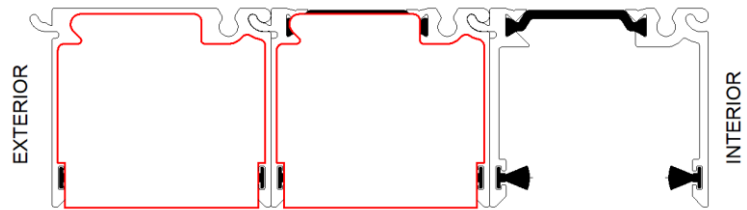

## 5 Keeper / Foam Installation (continued):

### Panel Stop:

- A. **If the door was purchased with Contemporary Handle**, a panel stop will be provided. The panel stop is to stop the active panel before the hardware handle contacts the 2<sup>nd</sup> panel. This stop will need to be mounted at the top rail of the vent panel.
- B. **Using the provided #10-32 Type-F screws**, mount the panel stop on using the pre-drilled holes on the top rail of the panel.



- C. **Once the unit installation is complete, the construction sill cover can be marked, cut to size and re-attached to the sill** to protect the exterior tracks from dust and debris on the job site. After the job is complete, the cover will need to be removed entirely.

## 6 STUCCO KEY:

If ordered, the Multi-Slide stucco key will be pre-installed on the head and jambs of the unit. The stucco return on the jamb sections will extend past the jamb on the unit.

**⚠ WARNING** The multi-slide stucco key frame accessory is intended for aesthetic purposes **ONLY** and should NOT be relied upon as the primary structural anchor for the door. **To ensure proper stability and performance, the frame must be securely fastened through the pre-drilled holes in the jambs, head, and sill.**

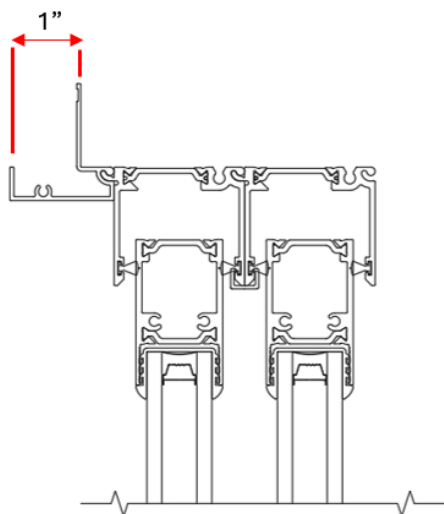

1" Stucco Key – Head Track

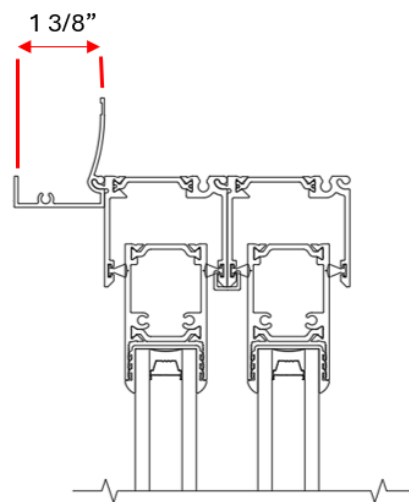

1 3/8" Stucco Key – Head Track

- A. Assemble the Multi-Slide frame per instructions – *Frame Assembly Pg. 9.*
- B. When assembling and installing the frame pieces in the rough opening, apply a bead of sealant on the back perimeter of the stucco key accessory.

## 6 STUCCO KEY (continued):

- C. **Once the frame has been assembled and installed in the rough opening,** there will be two pre-drilled holes located at each end of the head. Ensure the pre-drilled holes on the head and jamb line up. Drive a #8 -1" screw through the pre-drilled holes. Ensure the screws are flush with the stucco accessory before proceeding.

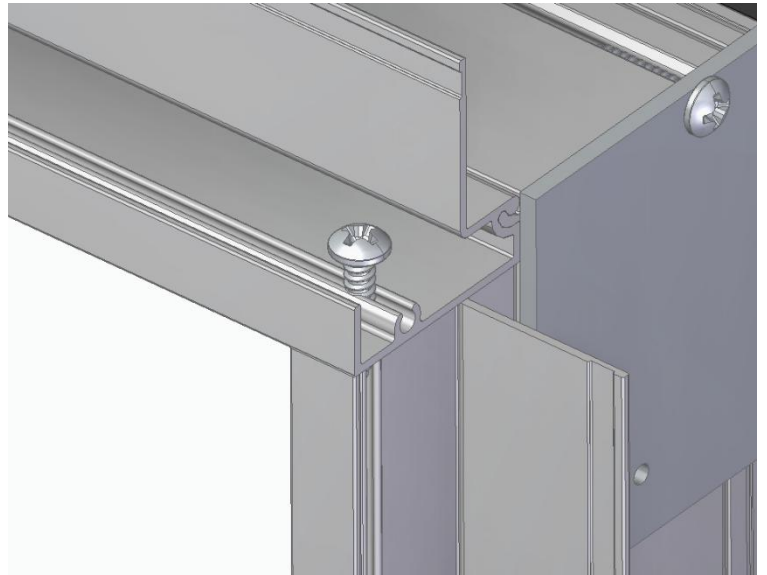

**Screw Location** – ensure this screw is flush before proceeding.

- D. **Once the screws have been secured in the stucco accessory,** there will be two metal plates, one for each corner to fill the gap between the stucco accessory.

- E. **Apply sealant to the back side of the plate,** where the double-sided tape is located. Ensuring that the sealant doesn't contact the tape. Apply the metal plate to both corners on the head of the unit.

- F. **Once the corners have been secured,** refer to *Panel Installation on Pg. 24.*

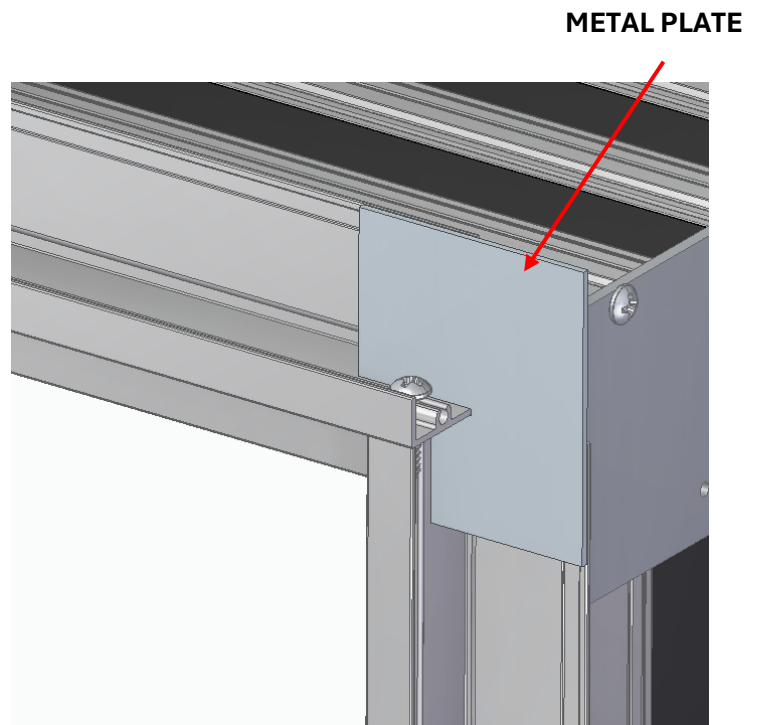

## 8 Panel Collector Installation:

Panel collectors are included with every unit and serve as an optional component that can be attached to the panels. The number of panel collectors provided depends on the panel count and configuration of the unit. For one-way pocket doors, the total number of panel collectors included will be two less than the total panel count. For bi-parting conditions the total number of panel collectors will be four less than the total panel count (two on each side). Units equipped with Aluminum Heavy Duty Interlockers eliminate the need for panel collectors, therefore, these components won't be supplied. The collectors will always be placed on the interior side of the intermediate panels and will never be installed on the exterior side or on the venting and fixed panel(s). For example, a 5-panel single-stacking pocket door will include 3 panel collectors. See placement below (panel collectors shown in red):

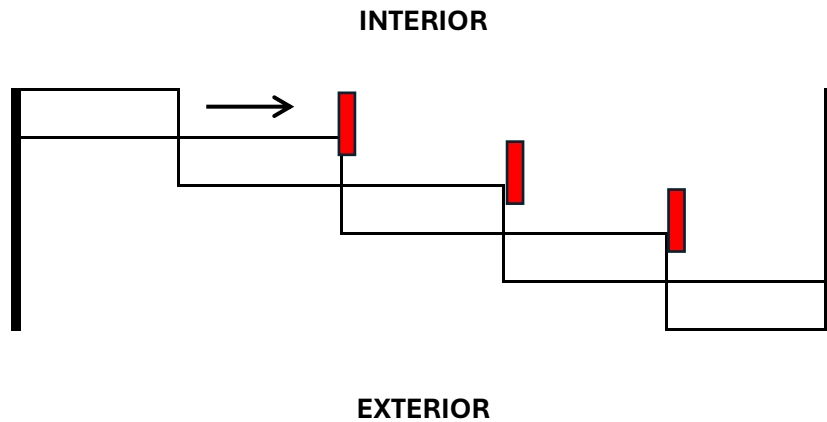

- A. **Place the provided plastic jig** on the interior side of the panel.
- B. **Move the jig upward until it's fully seated against the panel cap**, make sure there is no gap.
- C. **Using a #29 drill bit**, drill four pilot holes through the panel using the jig as a guide.
- D. **Remove the jig from the panel.**
- E. **Align the panel collector** with the pilot holes.
- F. **Secure the collector to the panel** using the four provided screws.

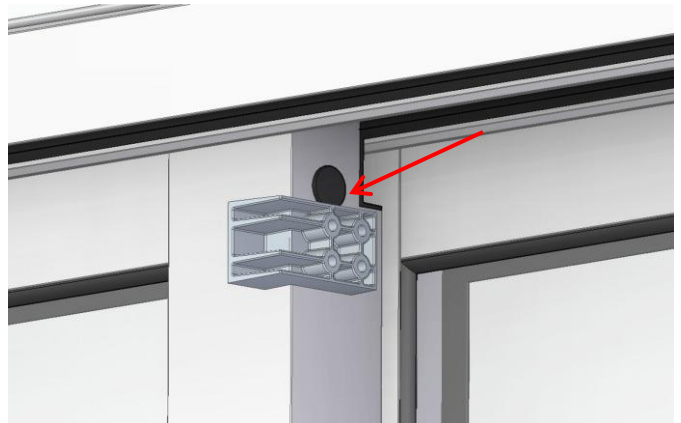



# INTERIOR AND EXTERIOR SEALANT

## Interior Sealant Instructions

**CAUTION:** Continuous backer rod (as necessary) and a high quality, low-odor interior sealant is recommended for commercial or high performance installations to create the continuous interior seal. Follow the directions on the cartridge. For standard performance, use low pressure polyurethane insulating foams. Follow the directions on the can. Do not use high pressure or latex foams. Fiberglass batt or similar insulation is not recommended as it can absorb water and does not act as an air seal.

- A. **Insert the nozzle** or straw between the rough opening and door frame from the interior. Use pliers (if necessary) to compress the end of a straw tube to allow it to fit in tight openings.
- B. **Place a 1" deep bead of foam** approximately 1" from the interior of the frame to allow for expansion. DO NOT fill the entire depth of the rough opening cavity.

**NOTE:** Apply foam between the frame and rough opening, NOT between jamb extensions and the rough opening.

- C. **Re-check door operation** and remove remaining shipping spacers after foam installation. Excess foam may be removed with a serrated knife after it cures.
- D. **To ensure a continuous interior seal**, apply sealant over or around any shims or clips interrupting the foam seal.
- E. **Place a continuous bead of sealant** across the inner sill at the intersection of the door sill and subfloor. Continue the sealant 6" up each jamb.



## Exterior Sealant Instructions

**CAUTION:** Use a high quality, multi-purpose exterior. Follow the directions on the cartridge.

**When applying siding, brick veneer, flashing, or other exterior finish materials, leave adequate space between the door frame and the material for application of sealant.**

- A. **Insert backer rod 3/8" deep** in the space around the door. Backer rod adds shape and controls the depth of the sealant line.
- B. **Apply a continuous bead of sealant** to the entire perimeter of the door.
- C. **Shape, tool and clean excess sealant.** When finished, the sealant should be the shape of an hourglass

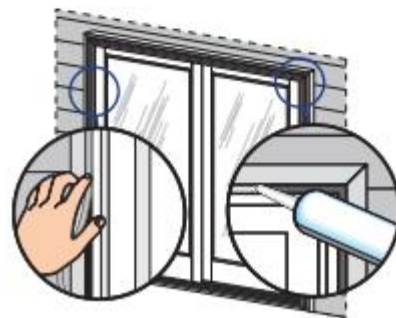



## OPTIONAL SILL PAN INSTRUCTIONS

**NOTICE:** The method of pan construction, flashing, and sealant application may vary depending on the design of the opening sill and exterior landing surface conditions. It is important to consider exposure to weather, the exterior landing surfaces proximity to the door sill, and to confirm impervious exterior surfaces properly slope away from the door. Additionally, Sill pans are **NOT** included and will have to be provided by the installer if desired.

**NOTICE:** Anchoring through the sill and the rough opening is required. For additional sill sealant placement and installation details, go to the sill installation section on Pg. 10.

- A. Cut the sill pan to the width of the rough opening plus 2".

**NOTE:** The 2" added onto the rough opening width is for a 1" bend on each end.

- B. Make 1" cut in each fold at both ends of the sill pan.

**NOTE:** These cuts will allow the edges of the sill pan to be bent.

- C. Cut 1" off each end of the interior sill pan lip.

- D. Bend each end of the center panel up.

- E. Install the sill pan by sliding into place until the exterior sill pan lip is flush with the exterior of the rough opening.

- F. Apply sill flashing tap. Cut a piece of flashing tape 2" longer than the opening width. Apply at the bottom of the opening, covering the exterior sill pan lip as shown.

**NOTE:** If applicable, apply spray adhesive to building felt prior to applying the flashing tape.

- G. Cut a piece of flashing tape to width of the opening. Install tape to the sill pan and overlap the flashing tape from step 1F by 1". If needed add a second or third piece of flashing tape until the sill pan is covered to the interior sill pan lip.

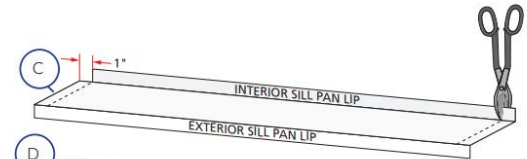
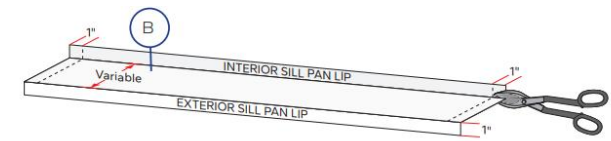

flush with

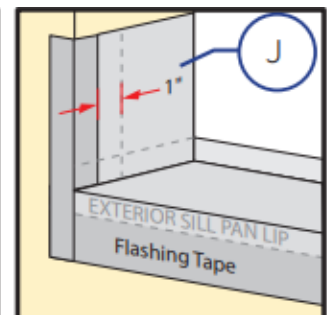
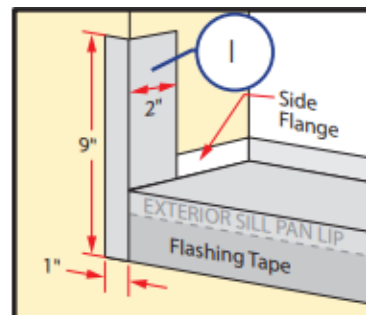
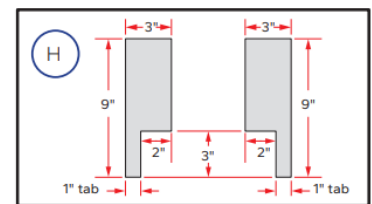
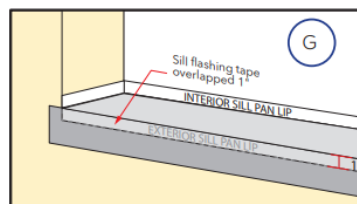
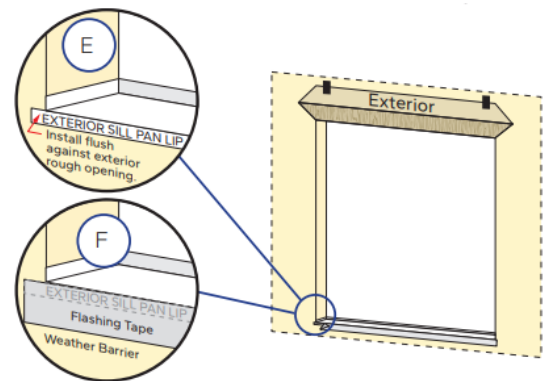

**NOTE: The purpose of this tape is to seal the sill screws when installing the door.**

**H. Cut two 9" pieces of flashing tape** with a 1" x 3" tab at the bottom, on the opposite corners as shown.

**I. Apply the tabbed 9" pieces of flashing tape.** The tape is applied so 2" will cover the inside of the rough opening and lap over the side flange of the sill pan. The 1" x 3" tab laps over the bottom flashing tape as shown.

**J. Cut two 6" pieces of flashing tape** and apply to each side of the rough opening, overlapping the first piece by 1" and lapping the bottom over the side flange of the sill pan as shown.

**K. Cut two pieces of flashing tape 1-1/2" x 6"** and apply to the bottom corners of the opening by beginning in the corner of the sill pan, with 3/4" of the tape applied to the sill pan and 3/4" of the tape applied to the side flange. The remainder of the tape is to be at a 45 degree angle onto the exterior.

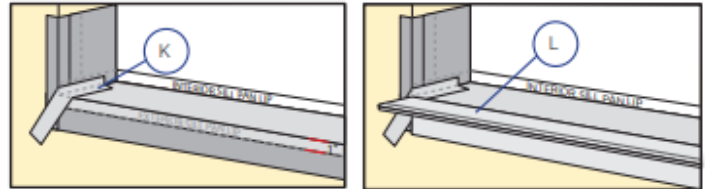

**L. Attach the aluminum sill support** or wood blocking to the exterior of the box plate to support the edge of the door sill. Place the sill support flush with the subfloor

### Concrete Slab (without sill pan) Instructions

**NOTE: Thoroughly clean the slab where sealants will be installed. Instead of installing flashing tape across the bottom of the rough opening, complete the following:**

**A. Install flashing tape at the bottom 6" of the rough opening jambs.**

**B. Cut two 9" pieces of flashing tape** as shown in step 1H above.

**C. Install them overlapping** the flashing tape installed in step A by 1".

**D. Place a 3/8" bead of sealant** where the bottom edge of the flashing tape meets the concrete slab.

**E. When folding building wrap in at the jambs,** cut at a 30 degree angle as illustrated.

Follow the applicable installation method pages to complete the installation except seal the door sill directly to the slab.

