



BONELLI POCKET MULTI-SLIDE DOOR AND WINDOW INSTALLATION INSTRUCTIONS

Contents:

Part/Tools	3
Product Safety Information.....	4
Care and Maintenance	5
Installation Information	6
Construction Sill.....	7
Opening Preparation	8
Frame Assembly	11
Spliced Unit Frame Installation.....	20
Corner Unit Frame Installation.....	27
Panel Installation	36
Keeper / Foam Installation.....	41
Panel Collector.....	42
Interior and Exterior Sealant	43
Sill Pan Instructions.....	44



BEFORE BEGINNING FRAME ASSEMBLY AND INSTALLATION:

Read through and understand all the assembly steps and the installation process.

Carefully remove shipping/packaging materials and check for any product damage.

Confirm the correct product was received. (Size, color, handing, etc..)

If there are any parts missing, product damage, wrong parts, or other issues...



DO NOT assemble! Contact Pella Customer Service at: 877-473-5527. Or contact your local sales representative or customer service team.

Before purchasing and installing, verify performance of product meets the requirements of the application and region. Not all products or sill types are rated for water performance. To reduce the likelihood of water infiltration where application exceeds product performance, install doors under an overhang that extends to meet a 45-degree line from the door sill and slope the exterior 2 degrees away from the door or use a stepdown.

FAILURE TO DO SO MAY RESULT IN DAMAGE TO THE INTERIOR OF THE STRUCTURE.

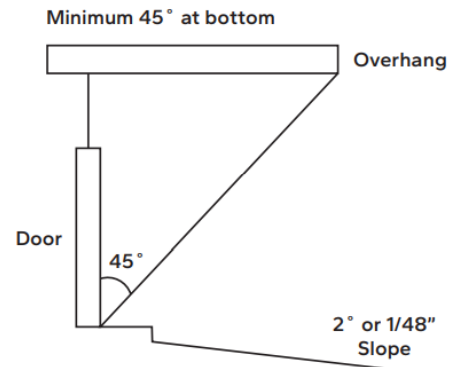



POCKETING MULTI-SLIDE SUPPLY LISTS

Tools / Supplies (Not Provided):

- #2 Phillips handheld screwdriver
- Level
- Square
- Safety glasses
- Utility knife
- Wood block
- Tape measure
- Drill with 3/16" & 7/64" drill bits
- Drill with masonry bit for concrete applications
- Fine tooth miter saw
- Sealant gun with polyurethane sealant
- Speed square
- Laser Level (Recommended)
- Moisture resistant shims/spacers (12 to 20)
- Foil backed butyl window and door flashing tape
- Writing utensil (pencil, marker, etc.)
- Closed call foam backer rod/sealant backer (21 to 30 ft)
- High quality, multi-purpose window and door installation sealant
- Low expansion, low pressure polyurethane insulating window and door foam sealant. DO NOT use high pressure or latex foams
- Sill pan – Optional (Rough Opening Width +2)

Supplies (Provided):

- Head, jamb, sill, frame covers, panels, panel interlocks, panel closers
 - Single Pocket: One jamb
 - Double Pocket: No jambs
- Anchoring Screws (#10 x 2.5" PH)
- Pocket closer screws (#10 x 1" PH)
- Head & Sill foam plugs
- Head end plate & sill end plate assembly screws (#8 x 3/8" PH)
- Bristle pads
- Lock keeper anchor screws (#10 x 3" FH) (Single Pocket only)
- Fixed panel interior screws (#8 x 1-1/4" FH drill tip)
- Anchor Fluted Plugs (#10-12 x 1-1/2")
- Dust Plug (Single Pocket only)



IMPORTANT SAFETY AND PRODUCT INFORMATION

Safety Alert Symbol Reference: These symbols are intended to alert you to potential injury hazards and information. Obey all safety messages.



WARNING To ensure safety and security and help prevent property damage, including possible damage to your window or door, close and lock windows and doors any time they are not being used for venting on a nice day, and particularly during high winds or rain. Ensure all windows and doors are properly fastened to the wall structure according to the product anchor instructions. It is the responsibility of the Buyer or User, the architect, contractor, installer, or other construction professional to ensure the appropriate windows and doors are chosen for the project and the wall construction is designed to resist all loads in accordance with local building code requirements

WARNING Installation may require (2) or more persons for safety reasons.

CAUTION Many doors in older homes are painted with lead-based paint. Removal of old doors may disturb this paint. Proper precautions must be taken to minimize exposure to dust and debris. Consult state or local authorities and/or go to www.epa.gov/lead for more information.

NOTICE Bonelli products must be stored in an upright, level position not exposed to weather. The storage must be ventilated and provide protection from direct sunlight and excessive temperature.

IMPORTANT NOTICE Because all construction must anticipate some water infiltration, it is important that the wall system be designed and constructed to properly manage moisture. Bonelli is not responsible for claims or damages caused by anticipated and unanticipated water infiltration; deficiencies in building design, construction and maintenance; failure to install Bonelli products in accordance with Bonelli's installation instructions; or the use of Bonelli products in wall systems which do not allow for proper management of moisture within the wall systems. The determination of the suitability of all building components, including the use of Bonelli products, as well as the design and installation of flashing and sealing systems are the responsibility of the Buyer or User, the architect, contractor, installer, or other construction professional and are not the responsibility of Bonelli.

Bonelli products should not be used in barrier wall systems which do not allow for proper management of moisture within the wall systems, such as barrier Exterior Insulation and Finish Systems (EIFS) (also known as synthetic stucco) or other non-water managed systems. Except in the states of California, New Mexico, Arizona, Nevada, Utah and Colorado, Bonelli makes no warranty of any kind on and assumes no responsibility for Bonelli windows and doors installed in barrier wall systems. In the states listed above, the installation of Bonelli Products in barrier wall or similar systems must be in accordance with Bonelli's installation instructions

Always read the Limited Warranty before purchasing or installing Bonelli products. BY PURCHASING, INSTALLING OR USING BONELLI PRODUCTS (INCLUDES BONELLI GOODS AND BONELLI SERVICES), YOU AGREED TO THE TERMS OF THE LIMITED WARRANTY AND YOU AND BONELLI and its subsidiaries AGREE TO ARBITRATE DISPUTES ARISING OUT OF OR RELATING TO BONELLI PRODUCTS, AND YOU WAIVE ANY RIGHT TO PARTICIPATE IN A CLASS ACTION RELATED TO BONELLI PRODUCTS unless you opt out of the Arbitration Agreement no later than ninety (90) calendar days from the date you purchased or otherwise took ownership of your Bonelli Products. Opting out of the Arbitration Agreement will not affect the coverage provided by any applicable limited warranty pertaining to your Bonelli products. To opt out, you must send notice by email to info@bonelli.com, with the subject line "Arbitration Opt Out". For complete information, including the full terms and conditions of this Arbitration Agreement, which are incorporated herein by reference, please visit onelli.com/arbitration or email to info@bonelli.com with the subject line: "Arbitration Details".



CARE AND MAINTENANCE

GLASS: Remove any protective film and labels and clean the glass, using a soft, clean, grit-free cloth and mild soap or detergent. Be sure to remove all liquid by wiping dry or use a clean squeegee.

NOTICE DO exercise special care when cleaning coated glass surfaces.

NOTICE DO soak the glass surface with clean water and soap solution to loosen dirt.

NOTICE DO use a mild, non-abrasive window cleaning solution.

NOTICE DO dry all cleaning solutions from window gaskets, sealants and frames.

NOTICE DO NOT use scrapers of any size or type for cleaning glass.

NOTICE DO NOT apply any other types of film to the glass. Doing so could void product warranty.

NOTICE DO NOT allow dirt and residue to remain on glass for an extended period of time.

NOTICE DO NOT begin cleaning without rinsing excessive dirt and debris.

NOTICE DO NOT use abrasive cleaning solutions or materials.

NOTICE DO NOT allow metal parts of cleaning equipment to contact the glass.

NOTICE DO NOT trap abrasive particles between the cleaning materials and the glass surface.

NOTICE DO NOT lean any tools or materials against the glass surface.

NOTICE DO NOT allow splashed materials to dry on the glass surface.

NOTICE certain methods of interior shading, particularly the use of tinted films applied directly to the glass can generate excessive heat concentration within the insulating unit and thus lead to premature failure, not covered by glass warranty.

FRAME: Excessive debris in the sill can impede the operation of the unit. To maintain the sill track and operation, use the crevice attachment of the vacuum to remove debris. Additionally, ensure weep holes are free of debris at all times to allow for proper drainage.

NOTICE The aluminum surfaces of the doors are finished either by means of powder coat painting process, or by an "anodizing" process. In either case, abrasive or caustic cleaners, including paint removers and abrasive materials, such as steel wool, should not be used to remove dirt or debris from these surfaces. Generally, the same cleaning parameters suggested above with regard to insulating glass are also appropriate here.

HARDWARE: Hardware is subject to deterioration from everyday use, it is recommended to carry out routine maintenance on all hardware to ensure proper operation.

NOTICE To help prevent surface corrosion, wash all hardware with soap or mild detergent and warm water followed by rinsing with clean cold water and wipe dry.

NOTICE In coastal or marine environments, it is recommended to apply a light application of corrosion preventative to hardware surfaces and using a dry cloth to remove excess. When using lubricant or corrosion protection compounds, be careful to avoid the adjacent surfaces and always follow the manufacturer's instructions (Applies to Hanger/Pivots, Guides, and Hinges).



INSTALLATION INSTRUCTIONS FOR TYPICAL WOOD FRAME CONSTRUCTION

NOTICE Header must be designed to bear the weight of all building (roofing) and construction loads. Maximum allowable deflection of 1/8" over total span of the opening

NOTICE Sill structure and framing must be designed and constructed to carry the weight of the door frame and door panels.

Installation Instructions for Typical Wood Frame Construction:

These instructions were developed and tested for use with typical wood frame wall construction in a wall system designed to manage water. These instructions are not to be used with any other construction method.

Building designs, construction methods, building materials, and site conditions unique to your project may require an installation method different from these instructions and additional care. Determining the appropriate installation method is the responsibility of you, your architect, or construction professional.

NOTICE When installing multiple tracks, ensure the threshold is level along the entire length of the opening and across the distance from the interior to the exterior.

NOTICE Rough opening sill must be within 1/8" of being level before proceeding with installation.

NOTICE FAILURE TO PROVIDE ADEQUATE ROUGH OPENING SILL PROTECTION FOR WOOD THRESHOLDS WILL RESULT IN VOIDING THE PRODUCT WARRANTY.

NOTICE Proper steps must be taken when flashing and applying sealant to ensure proper waterproofing of the unit.

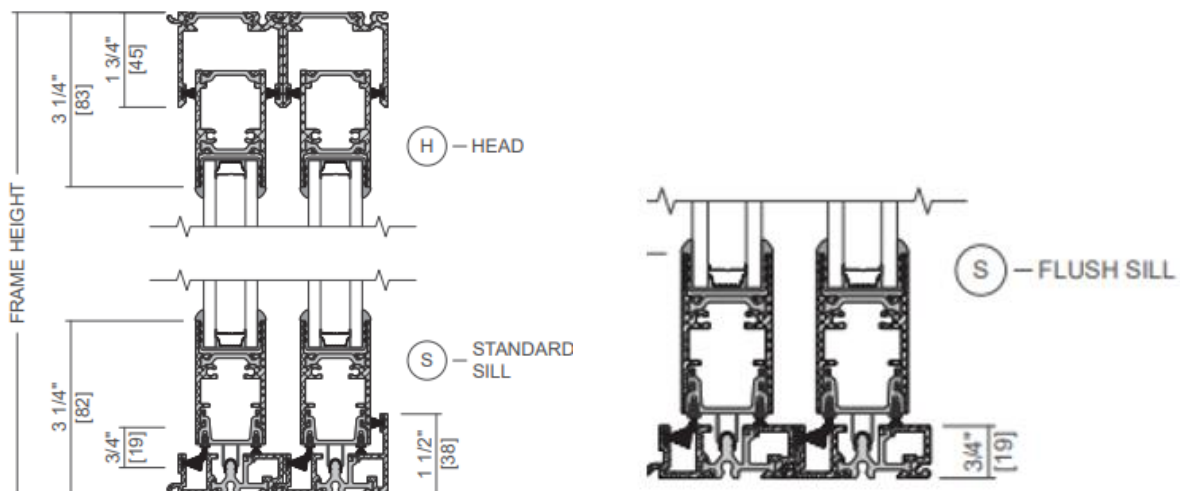



CONSTRUCTION SILL

The construction sill is a protective cover that snaps into the sill tracks to reduce the amount of dirt and debris getting into the track during the manufacturing, logistics, and installation processes as well as after installation on the jobsite.

During the installation process, the construction sill will need to be removed prior to assembling the frame and will remain out of unit through frame installation and panel installation.



Without Construction Sill

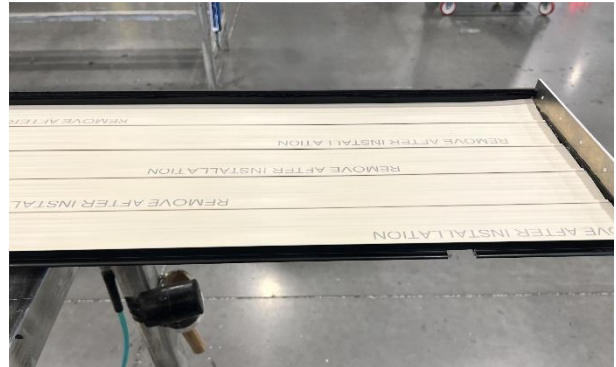

With Construction Sill

Once the panels have been installed into the frame, the cover can be marked, cut to size and re-attached to the sill to protect the exterior tracks from dust and debris on the job site. After the job is complete, the cover will need to be removed entirely.

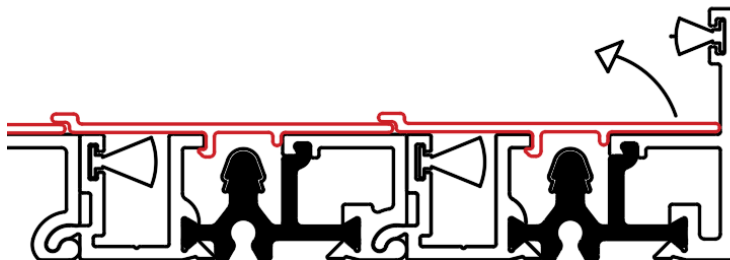

When removing the construction sill cover, begin at the innermost track. To prevent damage to the water sill weatherstrip. Carefully lift the interior part of the cover outward, moving continuously along its entire length. Avoid pulling the cover out from one side, as this can damage the weatherstrip

1 Opening Preparation:

A. **Prior to installation**, inspect the rough opening to ensure it is plumb, level, and square.

NOTICE It is critical the subfloor is level and does not slope to the interior or exterior. The rough open sill must not vary more than 1/16" per foot and 1/8" overall, and must be plumb, level and square before proceeding.

B. **Measure opening to confirm all measurements** agree with those appearing on elevation drawings provided. Measurements should be within 1/2" from side to side, the rough opening should measure no more than 1/2" larger than the unit is in width and height. Measurements from top to bottom should match the provided drawing.

Remove dirt, oil or debris from the opening and surrounding wall surfaces.

NOTICE It is important to consider the door's exposure to weather, the exterior landing surface type and its proximity to the door sill, and to confirm impervious exterior surfaces properly slope away from the door prior to continuing installation.

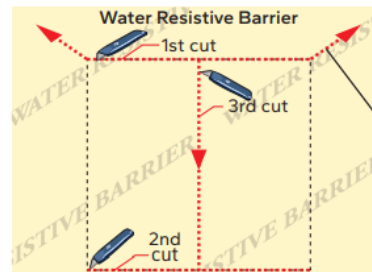

1D

4th cut:
Make a 6" cut up from each top corner at a 45° angle to allow the water resistive barrier to be lapped over the fin at the head of the door.

C. **Cut the building wrap.**

D. **Fold the building wrap in at the jambs and staple it in place.** Fold the top flap up and temporarily fasten with flashing tape

NOTICE If using a sill pan or if the door will be installed on a concrete slab, refer to the instruction page at the end of this instruction. When installing on wooden subfloors, it is advised to utilize a sill pan.

E. **Cut two pieces of flashing tape 12" longer than the opening width.**

F. **Apply flashing tape across the length of the sill** extending 1" to the exterior and 6" up the opposite jamb. Fold the tape over to the exterior. Place a piece of flashing tape across the exterior corner overlapping tape #1.

G. **Starting on the back side of the exterior wall** of the pocket, apply a piece of sill flashing tape (Tape # 2) to the framing with the tape edge on the sill.

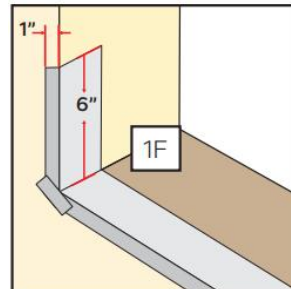
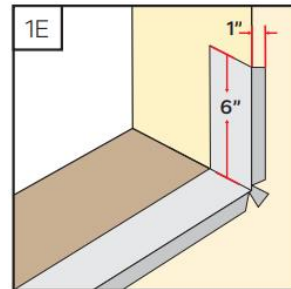

1 Opening Preparation (continued):

H. Continue applying the tap across the framing, around the corner to the inside edge of the pocket.



I. Starting at the corner in the backside of the pocket, apply a third piece of flashing tape overlapping tape #2 by at least 1". Work across the sill and apply the flashing tape 6" up the opposite jamb.

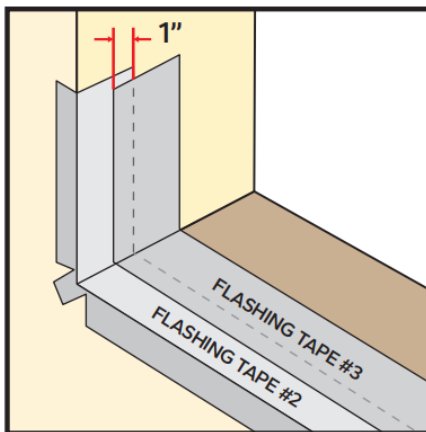

J. Continue to apply additional pieces of flashing tape across the sill, overlapping the previous piece by at least 1" until the sill is covered with flashing tape and up each jamb 6".



1 Opening Preparation (continued):

NOTICE Press all tape down firmly.

NOTICE The moisture barrier/sill flashing must be compliant with local building codes and compatible with build substrate.

NOTICE The following flashing method is applicable only if applied before building wrap.

The flashing method required for installing a pocket door is different than any other product because of how the door is set back from the exterior wall.

- **Cut 2 pieces** the height of the opening plus the thickness of the head flashing used.
- **Flash the strike side jamb** by wrapping it into the jambs framing so it sits behind the door's frame once installed
- **Using a utility knife**, notch the top corner and continue up the face of the wall
- **Flash the pocket side jamb** by wrapping the corner of the pockets wall, notch the top corner and continue up the face of the wall.
- **Cut the head flashing the width** of the opening plus twice the thickness of the jambs flashing.
- **Flash the header the same way** as the strike side so it will be tucked behind the door frame once installed, notch each end where they meet the jamb.



2 Frame Assembly:

IMPORTANT NOTICE If your unit has a splice or is a corner unit, please refer to the Spliced Unit section on Pg. 20 or Corner Unit section on Pg. 27

- A. **Unwrap packaged frame and identify frame parts necessary** (head, jamb, and a sill). The sill type can be determined by referencing the cross-sections shown below (1-1/2" Standard and 3/4" Flush).

Single pocket doors will have one jamb, dual pocket units won't have any jamb pieces.

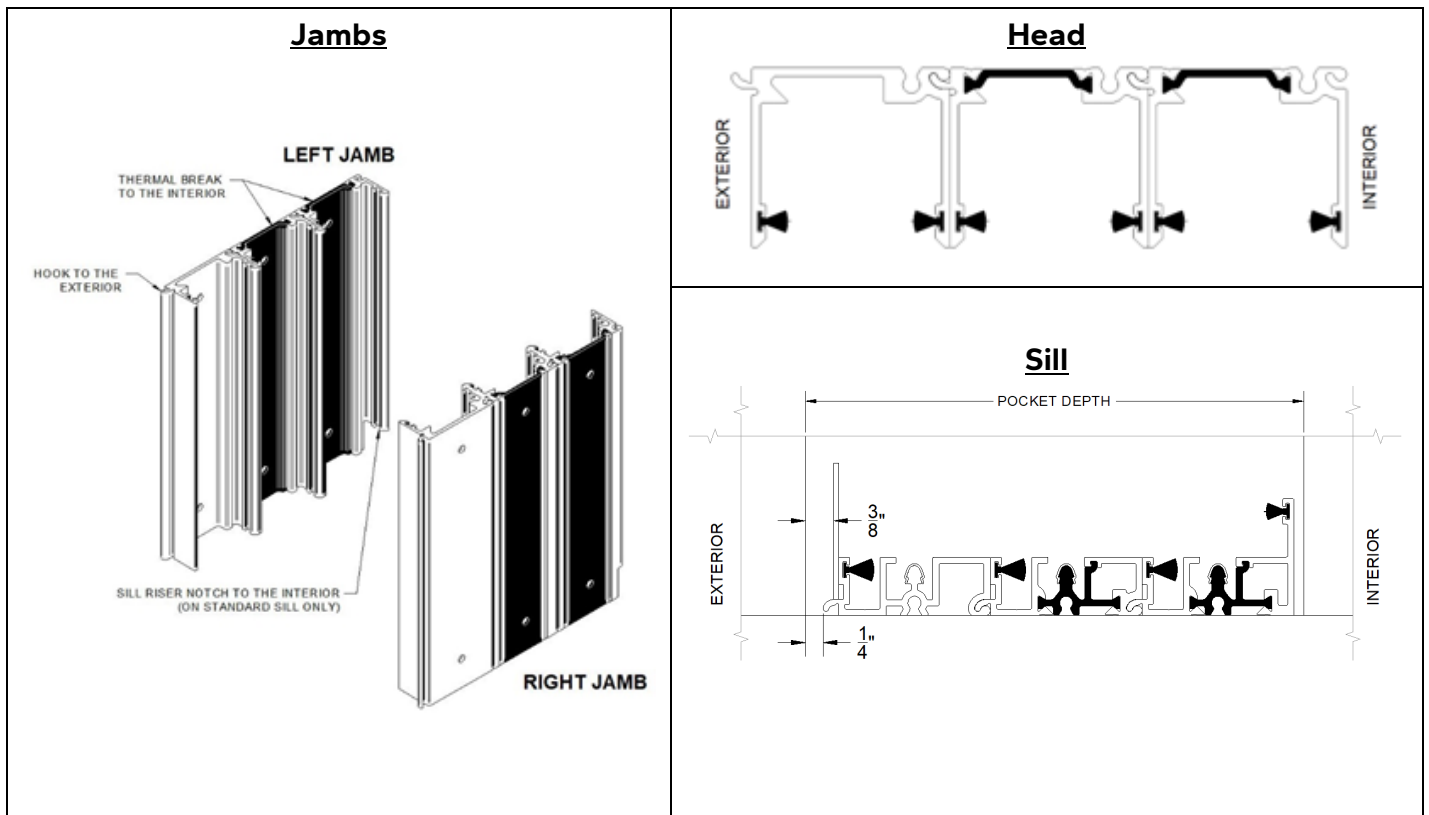
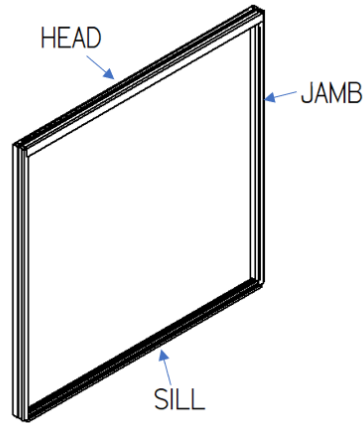

2 Frame Assembly (continued):

NOTICE The holes in the head, jamb, and sill will be pre-drilled.

NOTICE Use care if using an impact driver during the Frame Assembly Process. Impact drivers can cause screw head breakage.

SILL INSTALLATION:

- A. Place $\frac{1}{4}$ " shim where it will end up being between the exterior pocket wall and the frame

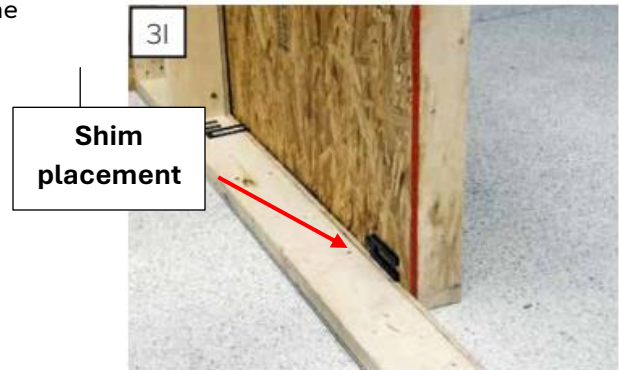

- B. Place and center the door sill into the opening, align the exterior sill riser plate with the pocket opening



- C. Once the sill is centered, verify the distance between the exterior pocket and the sill riser is $\frac{1}{4}$ " from the exterior framing and frame hook. Adjust shimming as needed.

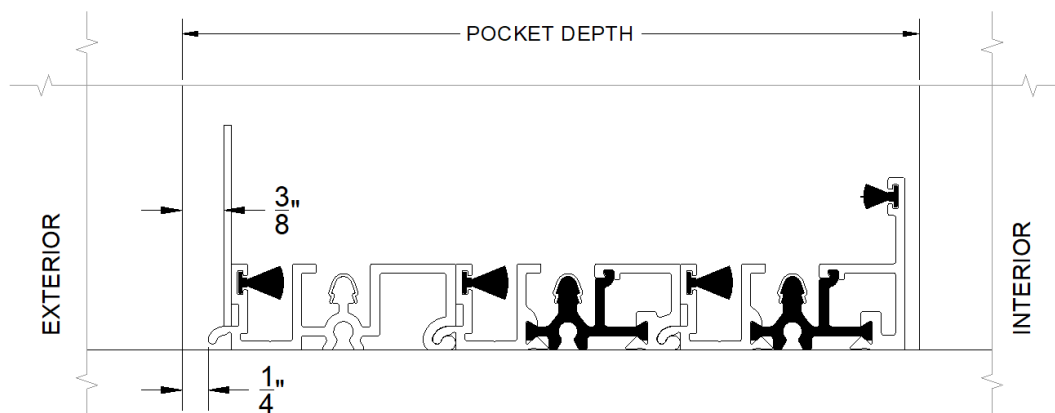

2 Frame Assembly (continued):

D. Using a marker, trace the entire length of the interior edge of the sill onto the rough opening.

Next, trace the vertical lines (jamb sides) at each end of the sill.

Then trace the entire pocket length on the exterior edge of the sill.

Lastly, mark the pre-drilled anchor hole locations – these are found on the interior and exterior tracks (and the middle track if it's a five-track frame), and about 4" from each end and spaced evenly along the length of the sill.

Helpful Tip: Please refer to the below sill marking placement chart for additional information:

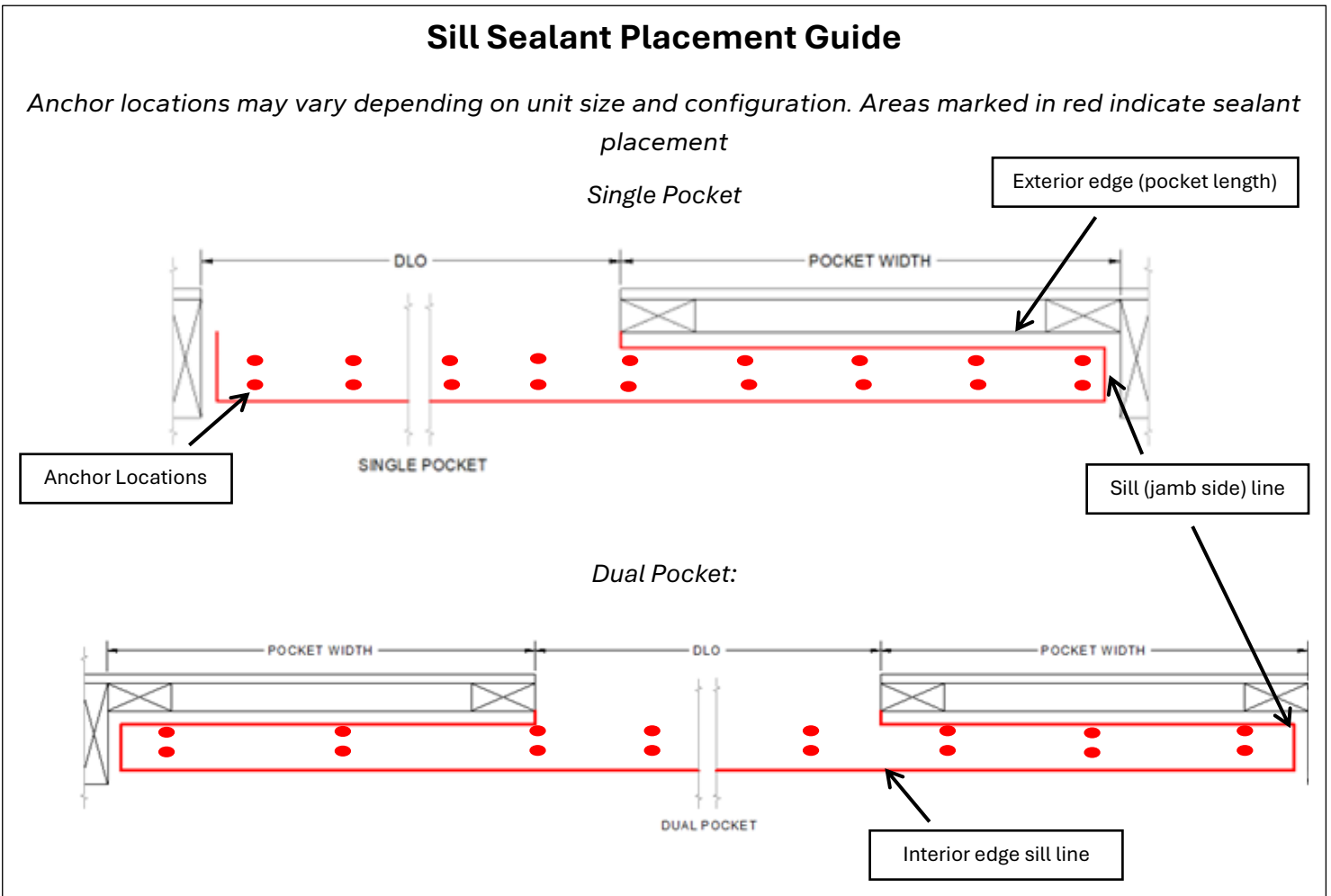

2 Frame Assembly (continued):

Sill Anchor Locations

(Center screw location on five track frames only)

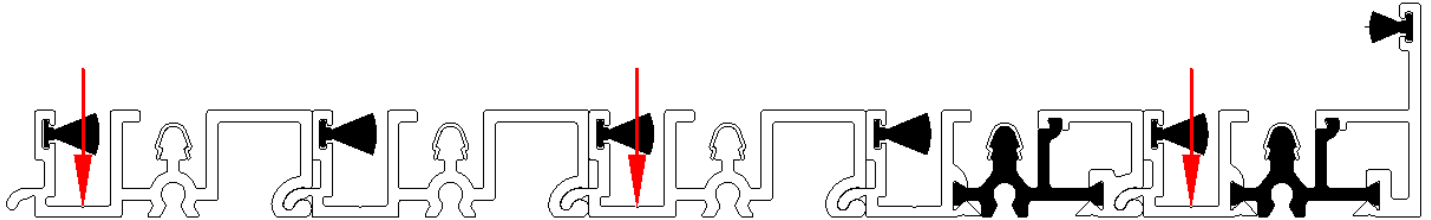

- A. **Once the sill locations have been marked on the rough opening**, remove the sill and set aside. Using a drill with #21-bit, pre-drill the sill anchor locations that were marked onto the rough opening.

NOTICE If the rough opening is concrete, use a masonry bit, pre-drill the anchor locations and install the provided anchor plugs at each location.

- B. **Once all anchor locations have been pre-drilled, apply a continuous 3/8" bead of sealant as follows:**

- Starting on one side of the rough opening, follow the sill marking line drawn on previous steps.
- Extend the sealant 6" vertically up both jambs of the rough opening at each end of the sill.
- Seal across the sill end marks and continue the bead down the length of the pocket(s), stopping at the pocket framing.



- C. **Lastly, apply a dot of sealant** at each pre-drilled anchor location.

NOTICE: Ensure the sealant forms a continuous, unbroken seal across the entire sill area. Refer to the Sill Marking Chart – Rough Opening on the previous page for visual guidance specific to your configuration.

2 Frame Assembly (continued):

- D. **After the sealant has been placed on the rough opening**, realign the sill in the rough opening, ensuring the sill is centered and lines up with the pre-drilled holes.
- E. **Once the sill is centered**, repeat step 2C and verify the distance between the exterior pocket and the sill riser is 1/4" from the exterior framing and frame hook. Adjust shimming as needed.

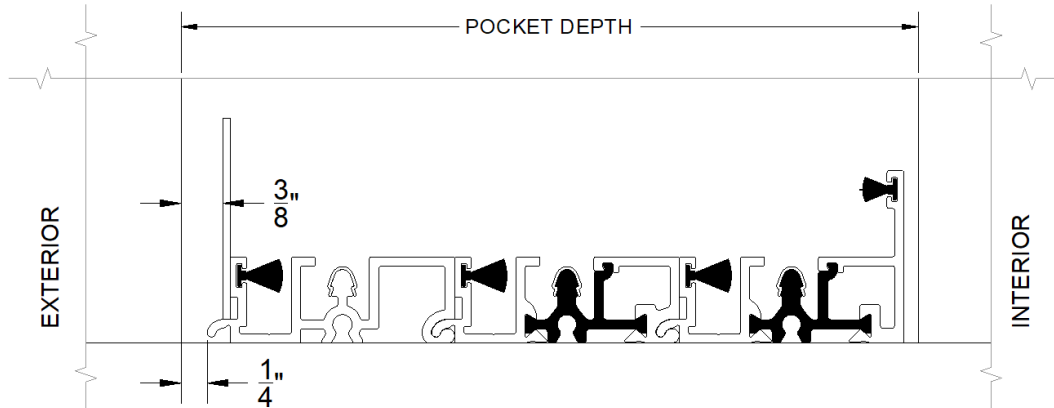

- F. **Shim as needed** between the end plate and the rough opening to prevent movement of the sill.
- Once the sill has been placed**, using the provided #10 x 1.5" anchor screws secure each end of the sill to the rough opening. Before securing the remainder of the sill, walk across the sill to ensure proper contact with the sealant.
- G. **Secure the remainder of the sill with the provided #10 x 1.5" anchor screws at each pre-drilled location.** Ensure the sill is within 1/8" tolerance of being level across the entire length of the sill and within 1/16" every foot be proceeding. Verify the sill is also plumb and level before proceeding.

NOTICE: If the sill is shimmed, make sure the shims are spaced closely enough to minimize flexing and that the sill remains within 1/16" of level for every foot.

2 Frame Assembly (continued):

JAMB & HEAD INSTALLATION

Single Pocket Installation (For Dual Pocket installation jump to Pg. 19)

A. **Locate the jamb**, refer to the diagram on Pg. 11 for reference.

B. **Starting on one side of the sill**, apply a 3/8" bead of sealant from interior corner of the end plate extending across the depth of the sill, to the exterior corner of the end plate. Ensuring sealant comes in contact with the pre-drilled installation holes in the end plate.

C. **Once the sealant has been applied to the end plate**, set the jamb onto the sill edge. Align the bottom of the jamb with the end plate, then firmly press the jamb against the plate to ensure full contact with the sealant.



Before proceeding, verify the interior and exterior edges of the jamb are flush with the sill and plumb to the opening.

D. **Once the jamb and sill are properly aligned**, secure the jamb to the sill by driving the provided #8 x 3/8" PH screws through the end plate. Clean any excess sealant.

E. **After the jamb has been secured through the end plate**, install the lower row of jamb anchor screws to hold the jamb in place for the remainder of the frame installation process. Larger units may require an additional row of anchors to hold the jamb in place.

At this stage of the installation, the jamb anchors do not need to be fully secured. The primary purpose of the lower row of anchor screws is to temporarily hold the jamb in position while the head is being installed. These screws will be removed later in the process and reinstalled with the appropriate amount of shims to ensure proper alignment and securement.

HELPFUL TIP: To aid with head installation it may be beneficial to stack shims or packaging foam towards the middle/top of the jamb. This will hold the jamb away from the stud and provide clearance to place the head piece for the jamb and head connection.

2 Frame Assembly (continued):

F. To ensure the head is level and properly secured, especially on larger units, using a gauge/guide board during head installation is highly recommended:

a. **Determine the frame opening height:**

Measure the unit frame height to establish your reference or refer back to the original quote.

b. **Prepare the Guide Board:**

Cut a board (ex. 2 x 4) approximately 2-1/2" shorter than the determined frame opening height. Place the board vertically on the sill. The guide board should be snug enough to hold the head frame in place, but able to temporarily be repositioned to assist with height checks during anchoring.

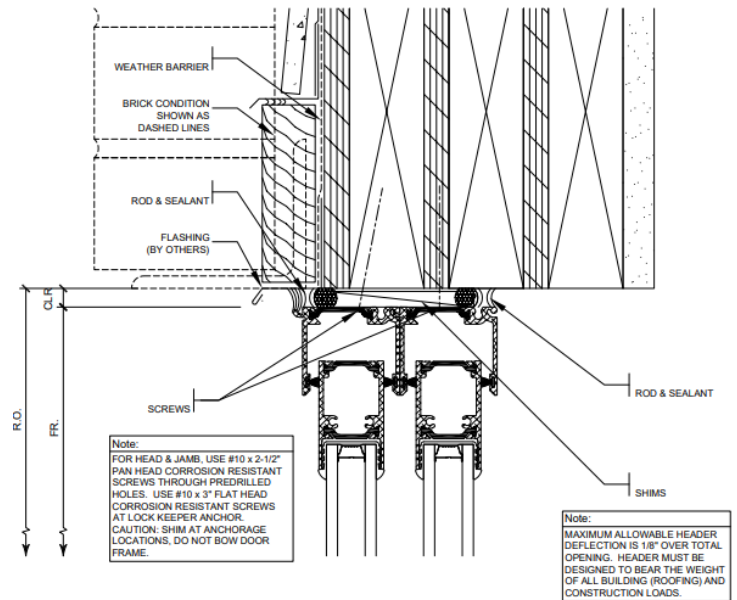

G. **Place the head of the frame in the rough opening**, ensuring the head end plates come in contact with the rough opening.

H. **Similar to the sill end plate sealant placement**, apply a 3/8" bead of sealant from interior corner of the end plate extending across the depth of the head, coming in contact with the head tracks, to the exterior corner of the end plate.

Once the sealant has been placed, remove any packaging foam and/or additional shims used to provide clearance for head installation, if applicable.

I. **Line up the jamb with the head** and firmly press the jamb against the plate to ensure full contact with the sealant. Clean any excess sealant. Add shims to the corners, behind the end plate as needed.

Once the jamb and head are properly aligned, secure the jamb to the head by driving screws through the end plate using the provided screws.



2 Frame Assembly (continued):

- J. **Once the head has been secured to the jambs**, remove the anchor screws used to hold the jamb in place during Step E. The bottom anchor screws will be re-installed with shims in the following steps.
- K. **On the jamb, starting at the sill**, insert and fasten an installation screw in each pre-drilled hole location with shim(s) between the frame and rough opening. Work up the jamb, checking with a level at every anchor location. Verify the jamb plumb and is within 1/8" of level the entire length of the jamb before proceeding.
- L. **Anchor and Verify Head Height Consistency:** Start anchoring at the center hole location of the head frame. Insert shims as needed and fasten the installation screw at the pre-drilled hole. Use the guide board to check head height consistency at this location.

Then, move the guide board horizontally along the sill from jamb side toward the pocket side. At each screw location:

- Insert shims as needed
- Use the guide board to verify the head height is consistent.
- Fasten install screw.

NOTICE: While checking, avoid dragging the board across the sill and head to prevent product damage.

- M. **Final Check:** After all screws are installed, confirm the head is level using a laser level before proceeding with the rest of the installation. Ensure the head is level and plumb with the sill. Confirm that the interior and exterior edges of the head align precisely with the sill at all points.

2 Frame Assembly (continued):

Dual Pocket Installation – Head Installation

NOTICE: Dual Pocket units do not have any jamb components. The following steps specifically outline the procedure for installing the head directly into the rough opening, as jamb installation is not applicable for this unit type.

Head Installation with Guide Boards

- A. **To ensure the head frame is level and properly secured, guide boards are highly recommended.**
- a. **Determine the unit frame height:** Measure the unit frame height to establish your reference or refer back to the original quote.
 - b. **Prepare Guide Boards:** Cut two boards (ex. 2 x 4) approximately 2-1/2" shorter than the determined frame opening height.
 - c. **Position the Head Frame:** Measure the depth from the frame sill to the rough opening. Place the head frame piece into the rough opening, aligning it with the measured depth.
 - d. **Place Guide Boards:** Position one guide board vertically on each side of the rough opening, to support and stabilize the head frame. If possible, have a helper hold the head frame in place while positioning the guide boards.

These boards should be snug enough to hold the head frame in place, but able to temporarily be repositioned to assist with height checks during anchoring.

- e. **Anchor and Check Head Height Consistency:** Start anchoring at the center hole location of the head frame. Insert shims as needed and fasten the installation screw at the pre-drilled hole. Use one of the two vertical guide boards to check head height consistency at this location.

Then, move the same guide board horizontally across the opening to each subsequent screw location as you continue anchoring outward from the center toward both ends. At each location:

- Insert shims as needed
- Use the guide board to verify the head height is consistent.
- Fasten install screw.

NOTICE: While checking, avoid dragging the board across the sill and head to prevent product damage.

- f. **Final Check:** After all screws have been installed, use a laser level to confirm the head is level and ensure the frame opening height is consistent across the entire width.

NOTICE: Refer to Pg. 36 for Panel Installation

3 Spliced Unit Frame Installation:

Units exceeding a certain height and/or width along with Corner doors will require additional installation requirements. This section goes into detail about the additional steps needed to complete the installation for large spliced units. If installing a Corner unit, jump to Pg. 27.

NOTICE: When installing spliced sill and head pieces, ensure there is less than 1/16" of separation where the splice locations meet.

A. Line up the two spliced sill pieces in the rough opening.

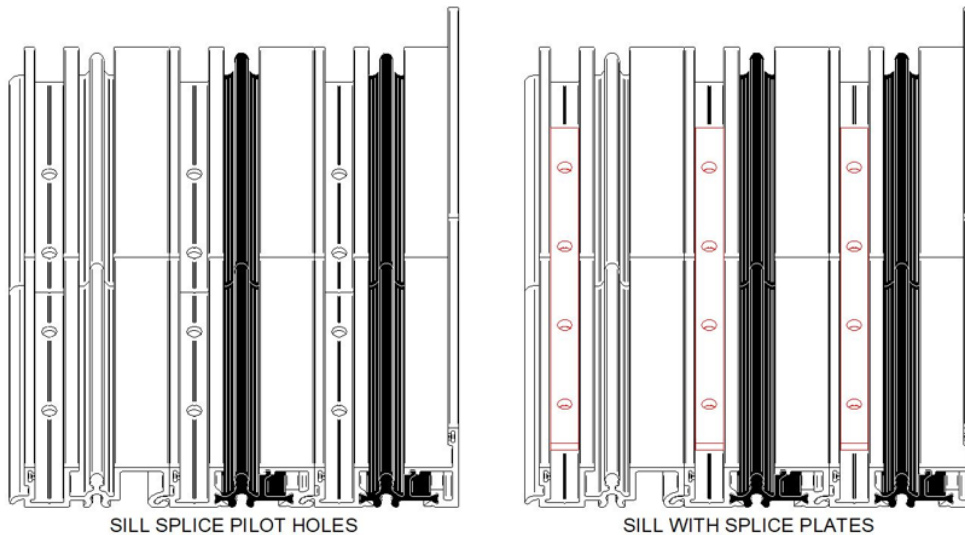

B. Place 1/4" shim where it will end up being between the exterior pocket wall and the frame

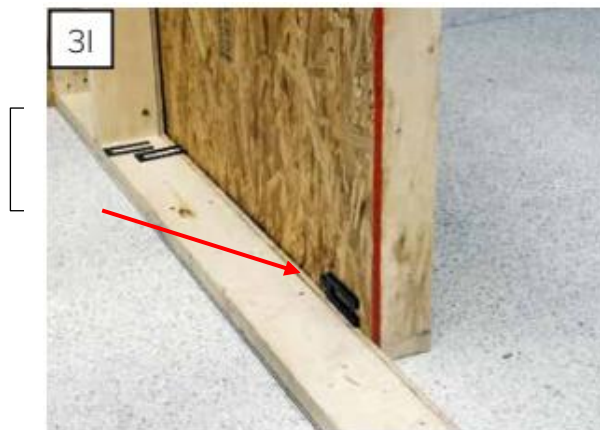

3 Spliced Unit Frame Installation:

- C. **Place and center the door sill into the opening**, align the exterior sill riser plate with the pocket opening



- D. **Once the sill is centered**, verify the distance between the exterior pocket and the sill riser is 1/4" from the exterior framing and frame hook. Adjust shimming as needed.

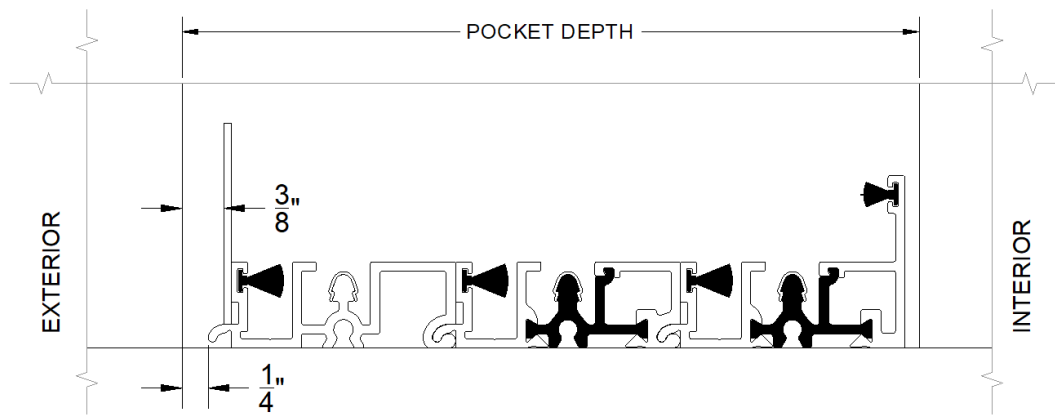

- E. **Using a marker, trace the entire length of the interior edge of the sill** onto the rough opening.

Next, trace the vertical lines (jamb sides) at each end of the sill.

Then trace the entire pocket length on the exterior edge of the sill.

Lastly, mark the pre-drilled anchor hole locations – these are found on the interior and exterior tracks (and the middle track if it's a five-track frame), and about 4" from each end and spaced evenly along the length of the sill. Make sure to mark all splice pre-drilled locations as well. Refer to the sill marking chart below for additional information

3 Spliced Unit Frame Installation:

- E. **Once the sill locations have been marked on the rough opening**, remove the sill pieces and set aside. Using a drill with #21-bit, pre-drill the sill anchor locations that were marked onto the rough opening, including at the spliced location.

NOTICE If the rough opening is concrete, use a masonry bit, pre-drill the anchor locations and install the provided anchor plugs at each location.

- F. **Once all anchor locations have been pre-drilled, apply a continuous 3/8" bead of sealant as follows:**

- Starting on one side of the rough opening, follow the sill marking line drawn on previous steps.
- Extend the sealant 6" vertically up both jambs of the rough opening at each end of the sill.
- Seal across the sill end marks and continue the bead down the length of the pocket(s), stopping at the pocket framing.

- G. **Lastly, apply a dot of sealant** at each pre-drilled anchor location.

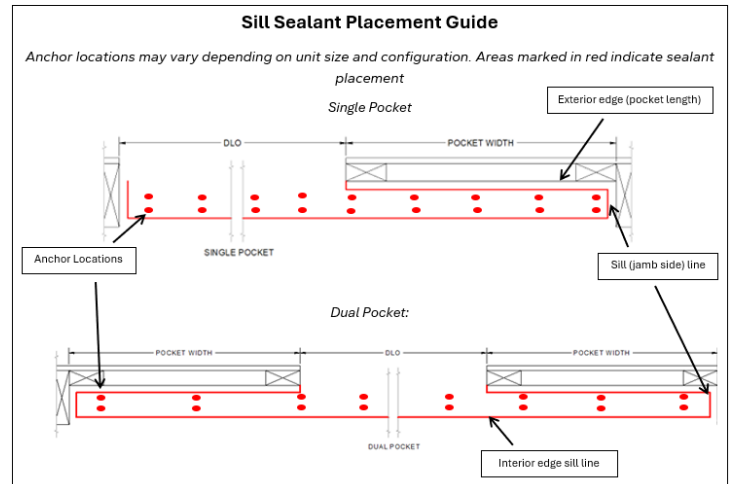

NOTICE: Ensure the sealant forms a continuous, unbroken seal across the entire sill area

- H. **Once the sealant has been applied**, realign the sill pieces in the rough opening and ensure the sill is centered and lines up at the splice locations. Apply a thin bead of sealant on the sill faces at the splice location.
- I. **Carefully check that both sill pieces are level with each other**, ensuring they are even and aligned on the same horizontal plane. This step is crucial for proper installation and function of the unit.

3 Spliced Unit Frame Installation:

- J. **Once the sill is centered**, repeat step 3C and verify the distance between the exterior pocket and the sill riser is 1/4" from the exterior framing and frame hook. Adjust shimming as needed.
- K. **Shim as needed** between the end plate and the rough opening to prevent movement of the sill.
- L. **Once the sill has been placed**, using the provided #10 x 1.5" anchor screws secure each end of the sill to the rough opening. Before securing the remainder of the sill, walk across the sill to ensure proper contact with the sealant. Apply a thin bead of sealant on the sill at the splice location, then place the splice plate where the two sill pieces come together to complete the connection.
- M. **Using the provided #10 x 1.5" anchor screws, begin anchoring the sill at the splice location**, through the pre-drilled holes in the splice plate, sill pieces and to the rough opening. Ensure the sill is within 1/8" tolerance of being level across the entire length of the sill and within 1/16" every foot before proceeding. Verify the sill is also plumb and square before proceeding.

Clean any excess sealant at the splice location.

- N. **Finish securing the sill** through the remainder of the pre-drilled hole locations.

NOTICE: If the sill is shimmed, make sure the shims are spaced closely enough to minimize flexing and that the sill remains within 1/16" of level for every foot.

NOTICE: To verify the sill is level, it is recommended to use a laser level.

Single Pocket Spliced Jamb and Head Installation (Dual Pocket jump to Pg. 26)

- A. **Starting on one side of the sill**, apply a 3/8" bead of sealant from interior corner of the end plate extending across the depth of the sill, to the exterior corner of the end plate. Ensuring sealant comes in contact with the pre-drilled installation holes in the end plate.
- B. **Once the sealant has been applied to the end plate**, set the jamb onto the sill edge. Align the bottom of the jamb with the end plate, then firmly press the jamb against the plate to ensure full contact with the sealant.

Before proceeding, verify the interior and exterior edges of the jamb are flush with the sill and plumb to the opening.

- C. **Once the jamb and sill are properly aligned**, secure the jamb to the sill by driving the provided #8 x 3/8" PH screws through the end plate. Clean any excess sealant.

4 Spliced Unit Frame Installation:

- D. **After the jamb has been secured through the end plate**, install the lower row of jamb anchor screws to hold the jamb in place for the remainder of the frame installation process. Larger units may require an additional row of anchors to hold the jamb in place.

At this stage of the installation, the jamb anchors do not need to be fully secured. The primary purpose of the lower row of anchor screws is to temporarily hold the jamb in position while the head is being installed. These screws will be removed later in the process and reinstalled with the appropriate amount of shims to ensure proper alignment and securement.

HELPFUL TIP: To aid with head installation it may be beneficial to stack shims or packaging foam towards the middle/top of the jamb. This will hold the jamb away from the stud and provide clearance to place the head piece for the jamb and head connection.

Once the jamb piece has been installed to the sill through the end plate, it is highly recommended to use a gauge or guide board during head installation, especially on large spliced units, to ensure the head is level and properly secured:

- E. **Guide Board Preparation:** Measure the unit frame height to establish your reference or refer back to the original quote. Cut two boards (ex: 2 x 4) approximately 2-1/2" shorter than the determined frame opening height.
- F. **First Head Piece Installation:** Locate the head piece that will be installed to the jamb piece; this piece will have an end plate. Place the head piece into the rough opening, ensuring the head end plate contacts the rough opening. Apply a 3/8" bead of sealant from the interior corner of the end plate, across the depth of the head (including head tracks), to the exterior corner.

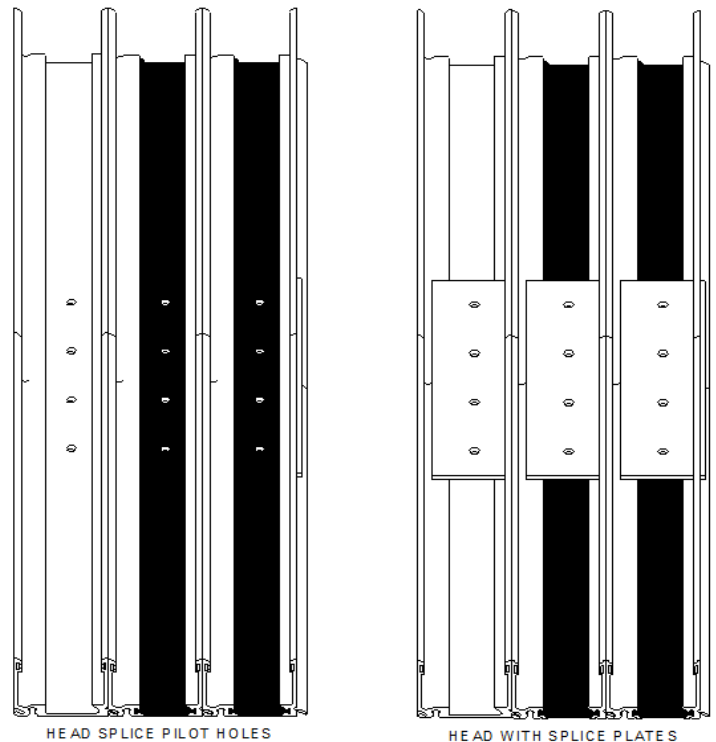

Remove any packaging foam or shims used for clearance during the jamb installation, if applicable.

4 Spliced Unit Frame Installation:

- G. **Jamb-to-Head connection:** Align the jamb with the head piece and press firmly to ensure contact with sealant. Clean excess sealant and shim behind the end plate as needed.

Secure the jamb to the head by driving screw through the end plate using the provided installation screws.

- H. **Guide board placement:** Place one of the previously cut guide boards at the splice location to the support and stabilize the installed head piece. This board should be snug enough to hold the head frame in place, but able to be temporarily repositioned to assist with height checks during anchoring.

- I. **Jamb Anchoring:** Once the head is secured to the jamb and first guide board is set, remove the temporary anchor screws, that were used to hold the jambs in place during the Jamb Installation section. Starting at the sill, insert and fasten an installation screw in each pre-drilled hole with shims between the frame and rough opening as needed.

Work up the jamb, checking with a level at each anchor location, ensuring the jamb is within 1/8" of level the entire length before proceeding.

- J. **Second Head Piece Installation:** With the jamb secured and first guide board still in place, insert the second head piece into the opening. Ensure the splice aligns with the first head piece and position the second guide board near the splice location. Once the guide board is in place, insert a few temporary anchor screws through the pocket side to hold the second head piece (these will be removed and reinstalled with shims later).

- K. **Splice Plate Preparation:** Once both head pieces are secured, leave guide boards in place to hold alignment during splice plate installation. Apply a thin bead of sealant along the face of the head at the splice location. Ensure the head is plumb before proceeding.

- L. **Splice Plate Anchoring:** Shim between the splice location and the rough opening. Using the provided #10 x 1.5" anchor screws, anchor the head at the splice location through the pre-drilled holes in the splice plate and head pieces into the rough opening. Shape, tool, and clean excess sealant.

NOTICE: Ensure the head and sill splice locations are perfectly aligned.

- M. **Final Head Anchoring:** Starting near the splice section, use one of the guide boards as a reference. Shim, insert, and fasten installation screws at each pre-drilled hole locations. Continue across the head, checking height with the guide board to ensure level installation. Remove and reinstall temporary anchor screws as needed.

Once all head screws are installed, it is highly recommended to verify the head is level with a laser level.

4 Spliced Unit Frame Installation:

Dual Pocket Spliced Head Installation

NOTICE: Dual Pocket units do not have any jamb components. The following steps specially outline the procedure for installing the head directly into the rough opening, as jamb installation is not applicable for this configuration.

- A. **Guide Board Preparation:** Determine the unit frame height by measuring the opening or refer back to the original quote. Cut a minimum of two guide boards (ex 2 x 4) 2-1/2" shorter than the determined frame opening height. This will be used to hold the head pieces at the splice location as well as a guide to ensure the head is level.
- B. **First Head Piece Installation:** Measure the depth from the frame sill to the rough opening. Place one of the head pieces into the rough opening, aligning it with the measured depth.
- C. **Guide Board Placement and Initial Anchoring:** Have a helper hold the end of the head piece closest to the rough opening. Place one of the guide boards at the splice location to the support and stabilize the head frame. This board should be snug enough to hold the head frame in place, but able to be temporarily repositioned to assist with height checks during anchoring.
- D. **Temporary/Initial Anchoring:** Insert a few temporary anchor screws through the pocket side to hold the head piece in place (these will be removed and reinstalled with shims later). Repeat this process for the second head piece.
- E. **Splice Plate Preparation:** Once both head pieces are secured through the end plates, leave the guide boards in place to maintain alignment during splice plate installation. Apply a thin bead of sealant along the face of the head at the splice location. Ensure the head is plumb before proceeding.
- F. **Splice Plate Anchoring:** Shim between the splice location and the rough opening. Using the provided #10 x 1.5" anchor screws, anchor the head at the splice location through the pre-drilled holes in the splice plate and head pieces into the rough opening. Shape, tool, and clean excess sealant.

NOTICE: Ensure the head and sill splice locations are perfectly aligned.

- G. **Final Head Anchoring:** Starting near the splice section, use one of the guide boards as a reference. Shim, insert, and fasten installation screws at each pre-drilled hole locations. Continue across the head, checking height with the guide board to ensure level installation. Remove and reinstall temporary anchor screws as needed.

Once all head screws are installed, it is highly recommended to verify the head is level with a laser level.

- H. Proceed to Pg. 36 for panel installation.

5 Corner Unit Frame Installation:

Similar to the larger units, corner units will always come with spliced frames that will require additional installation requirements. This section goes into detail about the additional steps needed to complete the installation for corner units.

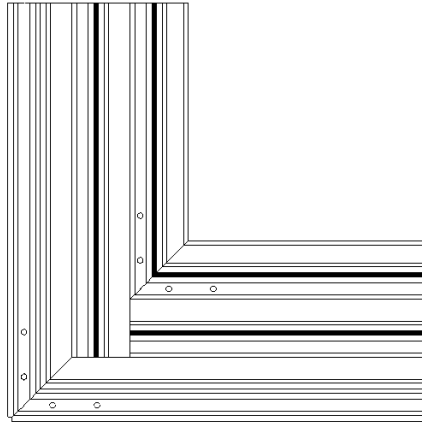

SILL 90-DEGREE SPLICE PILOT HOLES

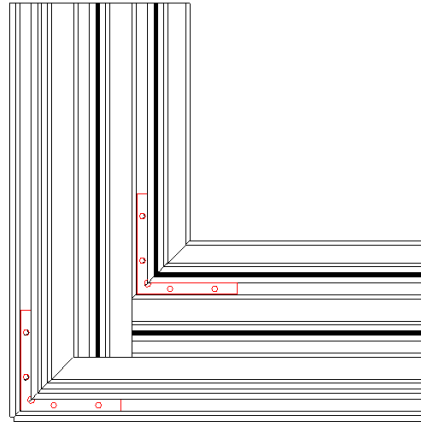

SILL WITH 90-DEGREE SPLICE PLATES

NOTICE: When installing spliced sill and head pieces, ensure there is less than 1/16" of separation where the splice locations meet.

NOTICE: Corner doors will always have two splice plates: the interior and exterior tracks.

- A. Line up the two spliced sill pieces in the rough opening.
- B. Place 1/4" shim where it will end up being between the exterior pocket wall and the frame
- C. Place and center the door sill into the opening, align the exterior sill riser plate with the pocket opening



5 Corner Unit Frame Installation:

- D. **Once the sill is centered**, verify the distance between the exterior pocket and the sill riser is 1/4" from the exterior framing and frame hook. Adjust shimming as needed.

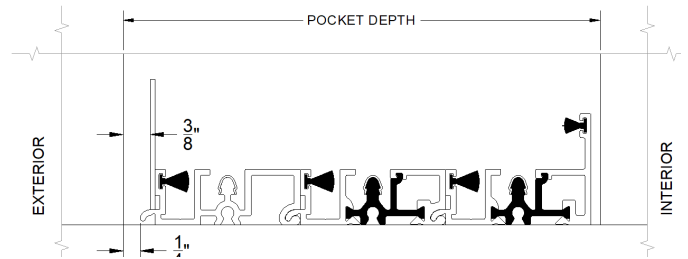

- E. **Using a marker, trace the entire length of the interior edge of the sill** onto the rough opening.

Next, trace the vertical lines (jamb sides) at each end of the sill.

Then trace the entire pocket length on the exterior edge of the sill.

Lastly, mark the pre-drilled anchor hole locations – these are found on the interior and exterior tracks (and the middle track if it's a five-track frame), and about 4" from each end and spaced evenly along the length of the sill. Make sure to mark all splice pre-drilled locations as well

Corner Door Sill Sealant Placement Guide

Anchor locations may vary depending on unit size and configuration. Areas marked in red indicate sealant placement.

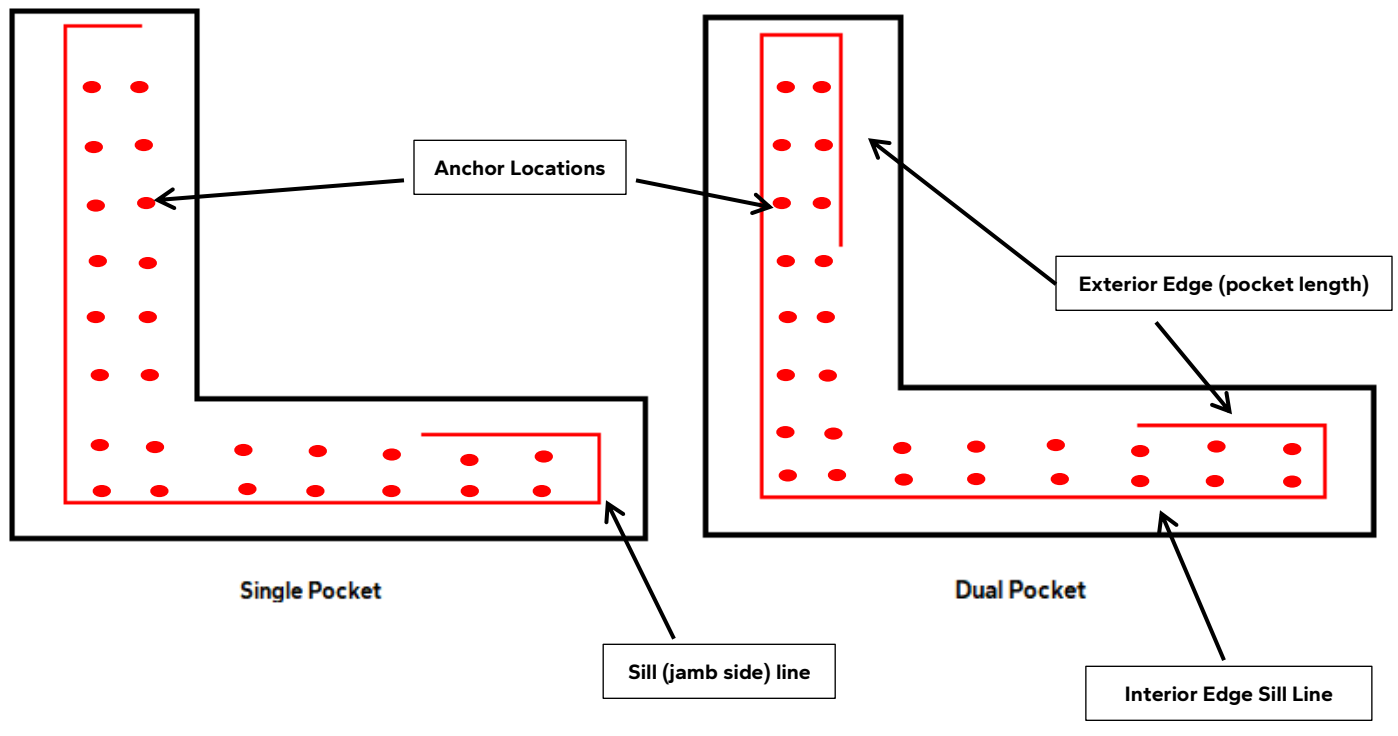

5 Corner Unit Frame Installation:

F. **Once the sill locations have been marked on the rough opening**, remove the sill pieces and set aside. Using a drill with #21-bit, pre-drill the sill anchor locations that were marked onto the rough opening, including at the spliced location.

NOTICE If the rough opening is concrete, use a masonry bit, pre-drill the anchor locations and install the provided anchor plugs at each location.

G. **Once all anchor locations have been pre-drilled, apply a continuous 3/8" bead of sealant as follows:**

- Starting on one side of the rough opening, follow the sill marking line drawn on previous steps.
- Extend the sealant 6" vertically up both jambs of the rough opening at each end of the sill.
- Seal across the sill end marks and continue the bead down the length of the pocket(s), stopping at the pocket framing.



Ensure the sealant forms a continuous, unbroken seal across the entire sill area. Refer to the Sill Marking Chart – Rough Opening on the previous page for visual guidance specific to your configuration.

H. **Lastly, apply a dot of sealant** at each pre-drilled anchor location.

I. **Once the sealant has been applied**, realign the sill pieces in the rough opening and ensure the sill is centered and lines up at the splice locations. Apply a thin bead of sealant on the sill faces at the splice location.

J. **Carefully check that both sill pieces are level with each other**, ensuring they are even and aligned on the same horizontal plane. This step is crucial for proper installation and function of the unit.

K. **Once the sill is centered**, repeat step J and verify the distance between the exterior pocket and the sill riser is 3/8" and 1/4" from the exterior framing and frame hook. Adjust shimming as needed.

L. **Shim as needed** between the end plate and the rough opening to prevent movement of the sill.

5 Corner Unit Frame Installation:

- M. **Once the sill has been placed**, using the provided #10 x 1.5" anchor screws secure each end of the sill to the rough opening. Before securing the remainder of the sill, walk across the sill to ensure proper contact with the sealant. Apply a thin bead of sealant on the sill at the splice location, then place the splice plate where the two sill pieces come together to complete the connection.

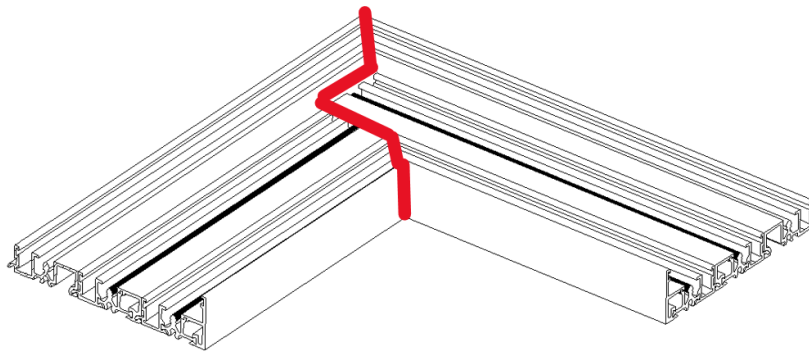

NOTICE: For Corner doors, it is important to ensure that the angle between the two sill sides is exactly 90 degrees - verify with an angle square.

- N. **Specifically, for corner units, to ensure the two sill pieces are perfectly aligned** and on the same plane, place a level diagonally across the corner, spanning both sills.

Carefully check that both sill pieces are level with each other, ensuring they are even and aligned on the same horizontal plane. This step is crucial for proper installation and function of the unit.

- O. **Using the provided #10 x 1.5" anchor screws, begin anchoring the sill at the splice location**, through the pre-drilled holes in the splice plate, sill pieces and to the rough opening. Ensure the sill is within 1/8" tolerance of being level across the entire length of the sill and within 1/16" every foot before proceeding. Verify the sill is also plumb and square before proceeding.

Clean any excess sealant at the splice location.

NOTICE: If the sill is shimmed, make sure the shims are spaced closely enough to minimize flexing and that the sill remains within 1/16" of level for every foot.

- O. **Finish securing the sill** through the remainder of the pre-drilled hole locations.

NOTICE: To verify the sill is level, it is recommended to use a laser level.

5 Corner Unit Frame Installation:

Single Pocket Corner Door Jamb & Head Installation (Dual Pocket jump to Pg. 34)

- A. **Locate the jamb**, refer to the diagram on Pg. 11 for reference.
- B. **Starting on one side of the sill**, apply a 3/8" bead of sealant from interior corner of the end plate extending across the depth of the sill, to the exterior corner of the end plate. Ensuring sealant comes in contact with the pre-drilled installation holes in the end plate.
- C. **Once the sealant has been applied to the end plate**, set the jamb onto the sill edge. Align the bottom of the jamb with the end plate, then firmly press the jamb against the plate to ensure full contact with the sealant.

Before proceeding, verify the interior and exterior edges of the jamb are flush with the sill and plumb to the opening.

- D. **Once the jamb and sill are properly aligned**, secure the jamb to the sill by driving the provided #8 x 3/8" PH screws through the end plate. Clean any excess sealant.
- E. **After the jamb has been secured through the end plate**, install the lower row of jamb anchor screws to hold the jamb in place for the remainder of the frame installation process. Larger units may require an additional row of anchors to hold the jamb in place.

The jamb anchors don't need to be fully secured at this point. The lower row of anchor screws main intent at this point in the installation process is to aid with holding the jamb in place while installing the head. Later in the installation process, we will pull these screws out and re-install with the appropriate amount of shims.

HELPFUL TIP: To aid with head installation it may be beneficial to stack shims or packaging foam towards the middle/top of the jamb. This will hold the jamb away from the stud and provide clearance to place the head piece for the jamb and head connection.

Once the jamb piece has been installed to the sill through the end plate, it is highly recommended to use a gauge or guide board during head installation, especially on large spliced units, to ensure the head is level and properly secured:

- F. **Guide Board Preparation:** Measure the unit frame height to establish your reference or refer back to the original quote. Cut two boards (ex: 2 x 4) approximately 2-1/2" shorter than the determined frame opening height.

5 Corner Unit Frame Installation:

- G. **First Head Piece Installation:** Locate the head piece that will be installed to the jamb piece; this piece will have an end plate. Place the head piece into the rough opening, ensuring the head end plate contacts the rough opening. Apply a 3/8" bead of sealant from the interior corner of the end plate, across the depth of the head (including head tracks), to the exterior corner.

Remove any packaging foam or shims used for clearance during the jamb installation, if applicable.

- H. **Jamb-to-Head connection:** Align the jamb with the head piece and press firmly to ensure contact with sealant. Clean excess sealant and shim behind the end plate as needed.

Secure the jamb to the head by driving screw through the end plate using the provided installation screws.

- I. **Guide board placement:** Place one of the previously cut guide boards at the splice location to the support and stabilize the installed head piece. This board should be snug enough to hold the head frame in place, but able to be temporarily repositioned to assist with height checks during anchoring.

- J. **Jamb Anchoring:** Once the head is secured to the jamb and first guide board is set, remove the temporary anchor screws, that were used to hold the jambs in place during the Jamb Installation section. Starting at the sill, insert and fasten an installation screw in each pre-drilled hole with shims between the frame and rough opening as needed.

Work up the jamb, checking with a level at each anchor location, ensuring the jamb is within 1/8" of level the entire length before proceeding.

- K. **Second Head Piece Installation:** With the jamb secured and first guide board still in place, insert the second head piece into the opening. Ensure the splice aligns with the first head piece and position the second guide board near the splice location. Once the guide board is in place, insert a few temporary anchor screws through the pocket side to hold the second head piece (these will be removed and reinstalled with shims later).

- L. **Splice Plate Preparation:** Once both head pieces are secured, leave guide boards in place to hold alignment during splice plate installation. Apply a thin bead of sealant to the interior corner of the head. Shape, tool, and clean excess sealant. See below for sealant location in red.

5 Corner Unit Frame Installation:

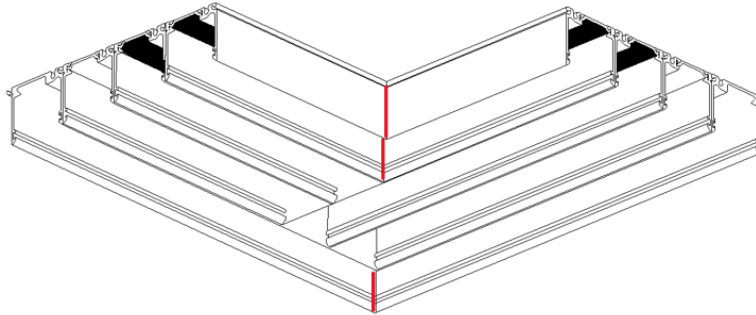

Ensure that the angle between the two head pieces is exactly 90 degrees, use an angle square prior to securing the head into the opening. Failure to do so may impact the door's operation and performance.

NOTICE Ensure the interior and exterior corner points of the head are perfectly aligned with the corresponding sill corners. Use a laser level to verify precise alignment.

- M. **Splice Plate Anchoring:** Shim between the splice location and the rough opening. Using the provided #10 x 1.5" anchor screws, anchor the head at the splice location through the pre-drilled holes in the splice plate and head pieces into the rough opening. Shape, tool, and clean excess sealant.
- N. **Final Head Anchoring:** Starting near the splice section, use one of the guide boards as a reference. Shim, insert, and fasten installation screws at each pre-drilled hole locations. Continue across the head, checking height with the guide board to ensure level installation. Remove and reinstall temporary anchor screws as needed.

Once all head screws are installed, it is highly recommended to verify the head is level with a laser level.

IMPORRANT NOTICE: For corner units, ensure that the head and sill on both sides of the corner are completely in plane with each other. Additionally, it is very important to ensure the frame is plumb, level, and square. It is recommended to use a laser level.

5 Corner Unit Frame Installation:

Dual Pocket Corner Head Installation

NOTICE: Dual Pocket units do not have any jamb components. The following steps specially outline the procedure for installing the head directly into the rough opening, as jamb installation is not applicable for this unit type.

- A. **Guide Board Preparation:** Determine the unit frame height by measuring the opening or refer back to the original quote. Cut a minimum of two guide boards (ex 2 x 4) 2-1/2" shorter than the determined frame opening height. This will be used to hold the head pieces at the splice location as well as a guide to ensure the head is level.
- B. **First Head Piece Installation:** Measure the depth from the frame sill to the rough opening. Place one of the head pieces into the rough opening, aligning it with the measured depth.
- C. **Guide Board Placement and Initial Anchoring:** Have a helper hold the end of the head piece closest to the rough opening. Place one of the guide boards at the splice location to the support and stabilize the head frame. This board should be snug enough to hold the head frame in place, but able to be temporarily repositioned to assist with height checks during anchoring.
- D. **Temporary/Initial Anchoring:** Insert a few temporary anchor screws through the pocket side to hold the head piece in place (these will be removed and reinstalled with shims later). Repeat this process for the second head piece.
- E. **Splice Plate Preparation:** Once both head pieces are secured through the end plates, leave the guide boards in place to maintain alignment during splice plate installation. Apply a thin bead of sealant to the interior corner of the head. Shape, tool, and clean excess sealant. See below for sealant location in red.

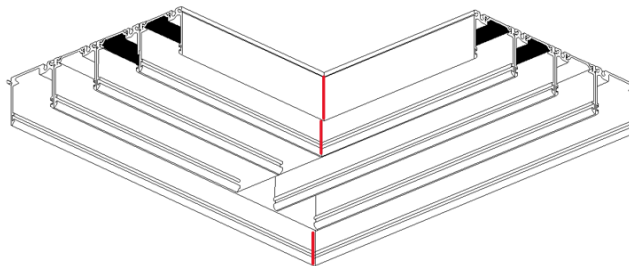

Ensure that the angle between the two head pieces is exactly 90 degrees, use an angle square prior to securing the head into the opening.

- F. **Splice Plate Anchoring:** Shim between the splice location and the rough opening. Using the provided #10 x 1.5" anchor screws, anchor the head at the splice location through the pre-drilled holes in the splice plate and head pieces into the rough opening. Shape, tool, and clean excess sealant.

5 Corner Unit Frame Installation:

NOTICE: Ensure the head and sill splice locations are perfectly aligned.

- G. **Final Head Anchoring:** Starting near the splice section, use one of the guide boards as a reference. Shim, insert, and fasten installation screws at each pre-drilled hole locations. Continue across the head, checking height with the guide board to ensure level installation. Remove and reinstall temporary anchor screws as needed.

Once all head screws are installed, it is highly recommended to verify the head is level with a laser level.

IMPORRANT NOTICE: For corner units, ensure that the head and sill on both sides of the corner are completely in plane with each other. Additionally, it is very important to ensure the frame is plumb, level, and square. It is recommended to use a laser level.

6 Panel Installation:

NOTICE: Before the panels are installed make sure all tracks are snapped securely in place. Use a block of wood and hammer and work down the entire length of the door's tracks. This will ensure the tracks are snapped into place which may have shifted during shipping.

Vent-Panel Installation:

- A. **Identify the interior-most panel** (the panel onto which handle hardware is located) and from the exterior, insert the panel. Start by inserting the top of the panel into the interior-most head track and top the bottom of the panel into vertical alignment, ensuring the rollers are aligned with the track.

Bi-parting units will have two interior-most panels. One panel will include a lock, while the other will include the lock keeper.

- B. **Remove the roller adjustment hole plugs.** Using a Phillips screwdriver, raise the roller on each side of the panel, so the panel is ~1/4" above the track.

HELPFUL TIP: Lift one corner up to take the weight off the roller.

- C. **Slide the vent panel over to the lock side jamb** and inspect the gap between the jamb and the stile. Ensure the gap is consistent along the entire length of the jamb. Repeat this procedure by sliding the panel to the fixed side jamb to ensure uniformity.
- D. **Install the next intermediate panel** into the next track following the process as the first vent panel.
- E. **Repeat 4C-4D** on this panel and subsequent vent panels.

6 Panel Installation (continued):

- F. **Verify proper interlock engagement** between vent and intermediate panels. Move panels to a closed condition to allow the interlock to engage, then compare engagement at the top and bottom of the panels. If interlocks appear to be out of alignment, adjust panels as needed.

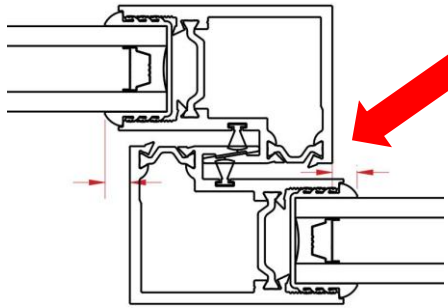

**Consistent
Interlock
Engagement**



- G. **Hold the locking vent panel and the 2nd vent panel together** and slide them as one. Check to see if the panels are sliding evenly together without shifting opposite of each other.

For bi-parting units, treat each side of the bi-part as one unit, checking the interlock engagement and panel operation of each side independently.

- H. **Follow steps 4E-4I** for subsequent vent panels.

6 Panel Installation (continued):

Panel Interlocks/Closer:

- A. **Locate the exterior pocket interlock(s).** For dual pockets there will be a left and right.

- B. **Line up the notch on the pocket interlock(s) with the sill.** Ensure the left and right pocket orientation is correct.

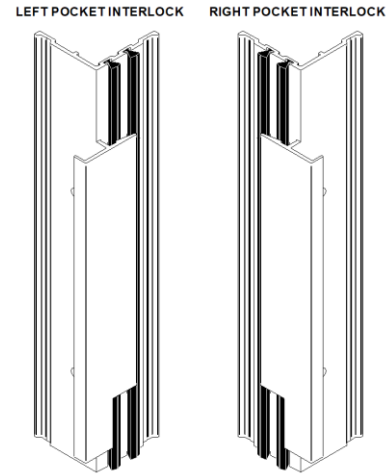

- C. **Set the pocket interlock in place, attach with anchors through the top and bottom pre-piloted holes.** Close panels to check interlock hook engagement. If required, loosen screws and shim behind interlock as needed. Do not shim more than 1/8". If you need more adjustment than that, readjust the frame instead. Once proper engagement is achieved, install remaining anchors

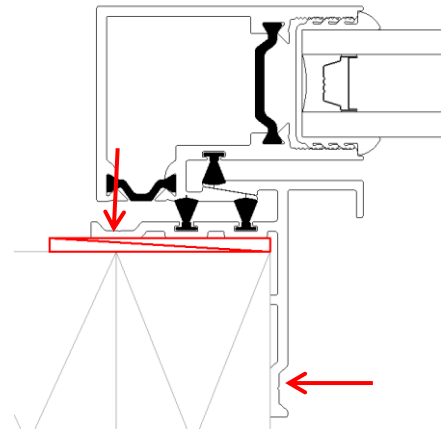

- D. **Apply sealant to the bottom of the pocket interlock, sealing between the pocket interlock, rough opening, and the door sill.** Tool and Clean excess sealant.

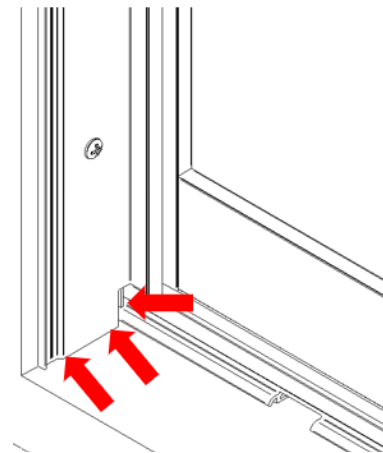

6 Panel Installation (continued):

- E. **Attach the pocket closer (filler) to the panel(s) closest to the pocket.** This piece will have a sticker on it from the factory, "Pocket Filler Do Not Discard".

Position the pocket closer against the exterior panel edge and up to the interlock notch as shown. Pilot drill $\frac{5}{32}$ " hole 1" from each end and 1" from the exterior panel edge. Attach using a #10 x $\frac{1}{2}$ " screw. Locate the additional fasteners 12" and 18" apart.



- F. **Locate the Interior pocket interlock(s).** For dual pockets there will be a left and right.

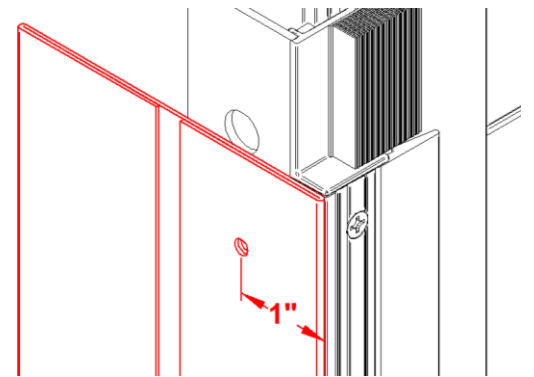

- G. **Set interior pocket interlock in place,** attach with anchors through the top and bottom pre-piloted holes. Close panels to ensure no overlap with lead panel. Once proper placement is achieved, install remaining anchors

INTERIOR LEFT INTERLOCK INTERIOR RIGHT INTERLOCK

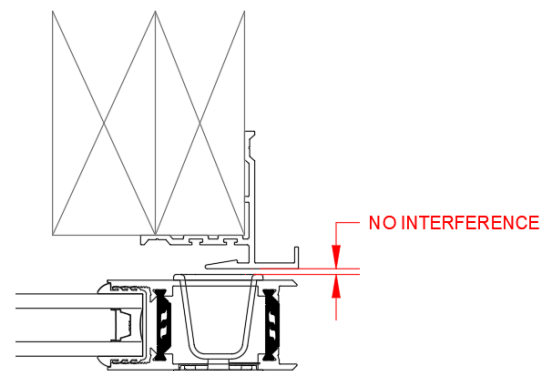
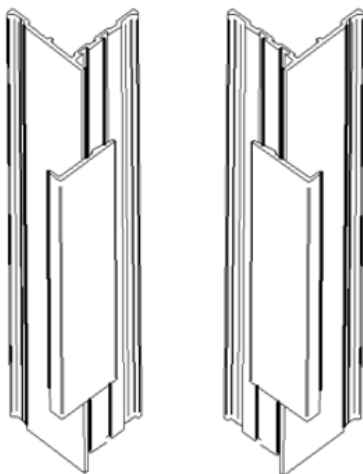

6 Panel Installation (continued):

Sill Bristle Pad & Sill Channel Foam Plugs:

- A. **Locate the sill bristle pads**, using the adhesive on the bottom of the bristle pad, install on the sill where the panels meet the lock side jamb and the fixed jamb.
- B. **Once you have verified proper placement of the sill bristle pad**, locate the sill channel foam plugs.
- C. **With the panels in the fully closed position**, mark each interlock location at the sill on the interior and exterior side.
- D. **Move the panels to the open position and insert a sill channel foam plug** into the sill channel at each location. The sill plug will extend approximately $\frac{1}{4}$ " past the interlock in both directions.

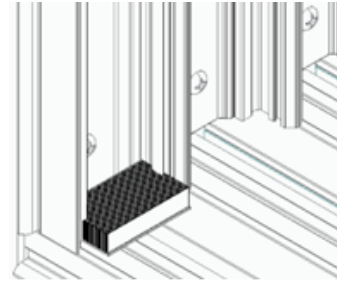

Sill Bristle Pad

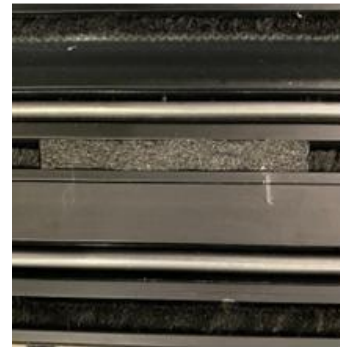

Sill Foam Plug

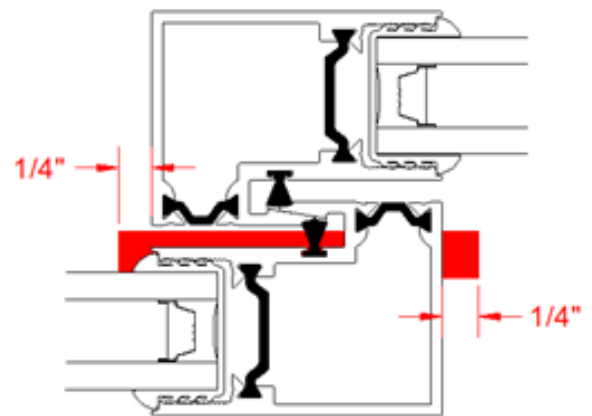
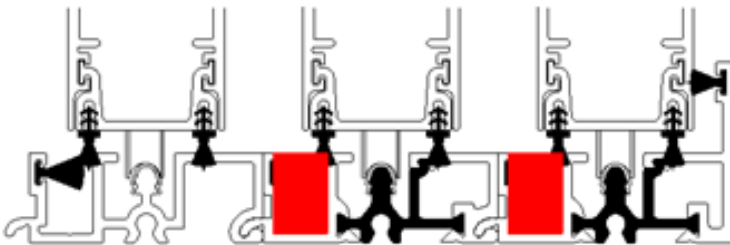

NOTICE: Ensure all panel interlocks engage properly, and the weatherstrip on the bottom of the panel maintains contact with the sill. Make any final panel adjustment before securing the fixed panel.

- E. **Re-install the panel roller adjustment plugs** before proceeding.

7 Keeper / Foam Installation:

Keeper Installation:

If the door has a one-way stacking configuration, adjust and secure the lock keeper now.

The lock keeper will come pre-installed on the lock side jamb with short screws. Slide the panels into the closed position and operate the lock a few times to confirm it engages the keeper.

- A. **If the lock does not engage**, pull out the small, short screws, adjust the height of the keeper. Verify the lock engages. Through the pre-drilled holes, secure the keeper with the long keeper installation screws.
- B. **If the lock engages the keeper open the door**, pull out the small, short screws. Through the pre-drilled holes, secure the keeper with long keeper installation screws.

Head Channel Foam Plugs:

- A. **Once the keeper has been secured**, identify the head foam plugs.
- B. **From the exterior of the head of the frame**, where the first and second panel meet, insert the foam plug in the channel in the head. Firmly press against the head track and panel to ensure the foam is seated properly.
- C. **Repeat process for all intermediate panels.** Head foam plugs are not required on the fixed panel.

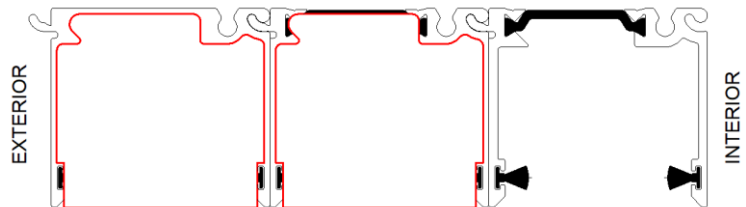

8 Panel Collector Installation:

Panel collectors are included with every unit and serve as an optional component that can be attached to the panels. The number of panel collectors provided depends on the panel count and configuration of the unit. For one-way pocket doors, the total number of panel collectors included will be two less than the total panel count. For bi-parting conditions the total number of panel collectors will be four less than the total panel count (two on each side). Units equipped with Aluminum Heavy Duty Interlockers eliminate the need for panel collectors, therefore, these components won't be supplied. The collectors will always be placed on the interior side of the intermediate panels and will never be installed on the exterior side or on the venting and fixed panel(s). For example, a 5-panel single-stacking pocket door will include 3 panel collectors. See placement below (panel collectors shown in red):

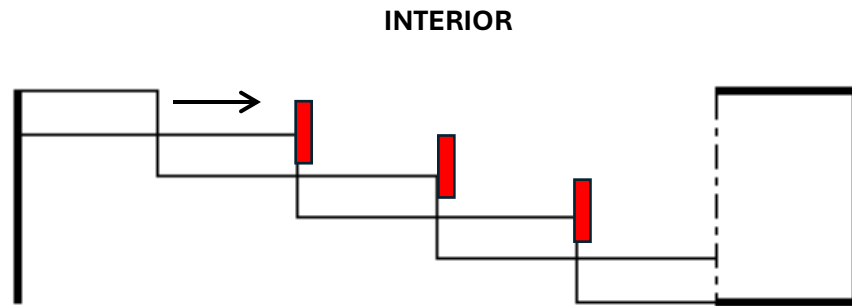

EXTERIOR

- A. **Place the provided plastic jig** on the interior side of the panel.
- B. **Move the jig upward until it's fully seated against the panel cap**, make sure there is no gap.
- C. **Using a #29 drill bit**, drill four pilot holes through the panel using the jig as a guide.
- D. **Remove the jig from the panel.**
- E. **Align the panel collector** with the pilot holes.
- F. **Secure the collector to the panel** using the four provided screws.

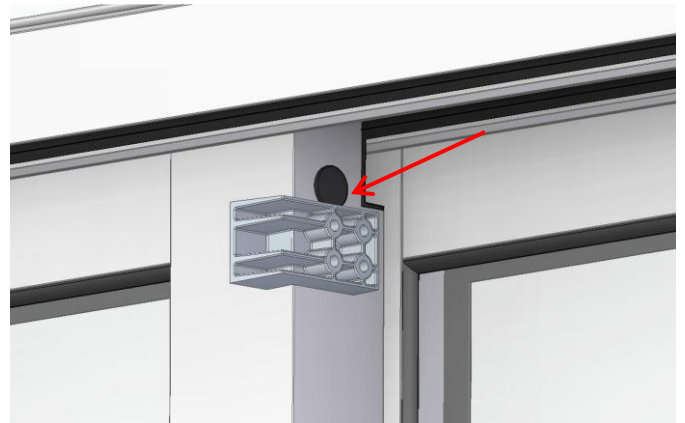



INTERIOR AND EXTERIOR SEALANT

Interior Sealant Instructions

CAUTION: *Continuous backer rod (as necessary) and a high quality, low-odor interior sealant is recommended for commercial or high performance installations to create the continuous interior seal. Follow the directions on the cartridge. For standard performance, use low pressure polyurethane insulating foams. Follow the directions on the can. Do not use high pressure or latex foams. Fiberglass batt or similar insulation is not recommended as it can absorb water and does not act as an air seal.*

- A. **Insert the nozzle** or straw between the rough opening and door frame from the interior. Use pliers (if necessary) to compress the end of a straw tube to allow it to fit in tight openings.
- B. **Place a 1" deep bead of foam** approximately 1" from the interior of the frame to allow for expansion. **DO NOT** fill the entire depth of the rough opening cavity.

NOTE: *Apply foam between the frame and rough opening, NOT between jamb extensions and the rough opening.*

- C. **Re-check door operation** and remove remaining shipping spacers after foam installation. Excess foam may be removed with a serrated knife after it cures.
- D. **To ensure a continuous interior seal**, apply sealant over or around any shims or clips interrupting the foam seal.
- E. **Place a continuous bead of sealant** across the inner sill at the intersection of the door sill and subfloor. Continue the sealant 6" up each jamb.



Exterior Sealant Instructions

CAUTION: *Use a high quality, multi-purpose exterior. Follow the directions on the cartridge.*

When applying siding, brick veneer, flashing, or other exterior finish materials, leave adequate space between the door frame and the material for application of sealant.

- A. **Insert backer rod 3/8" deep** in the space around the door. Backer rod adds shape and controls the depth of the sealant line.
- B. **Apply a continuous bead of sealant** to the entire perimeter of the door.
- C. **Shape, tool and clean excess sealant.** When finished, the sealant should be the shape of an hourglass

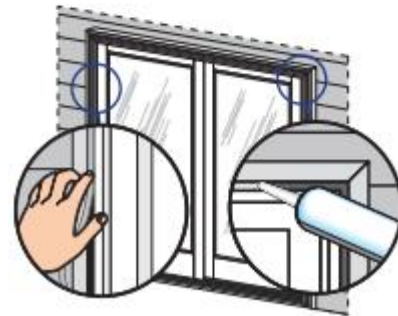



OPTIONAL SILL PAN INSTRUCTIONS

NOTICE: The method of pan construction, flashing, and sealant application may vary depending on the design of the opening sill and exterior landing surface conditions. It is important to consider exposure to weather, the exterior landing surfaces proximity to the door sill, and to confirm impervious exterior surfaces properly slope away from the door. Additionally, Sill pans are **NOT** included and will have to be provided by the installer if desired.

NOTICE: Anchoring through the sill and the rough opening is required. For additional sill sealant placement and installation details, go to the sill installation section on Pg. 10.

- A. Cut the sill pan to the width of the rough opening plus 2".

NOTE: The 2" added onto the rough opening width is for a 1" bend on each end.

- B. Make 1" cut in each fold at both ends of the sill pan.

NOTE: These cuts will allow the edges of the sill pan to be bent.

- C. Cut 1" off each end of the interior sill pan lip.

- D. Bend each end of the center panel up.

- E. Install the sill pan by sliding into place until the exterior sill pan lip is flush with the exterior of the rough opening.

- F. Apply sill flashing tap. Cut a piece of flashing tape 2" longer than the opening width. Apply at the bottom of the opening, covering the exterior sill pan lip as shown.

NOTE: If applicable, apply spray adhesive to building felt prior to applying the flashing tape.

- G. Cut a piece of flashing tape to width of the opening. Install tape to the sill pan and overlap the flashing tape from step 1F by 1". If needed add a second or third piece of flashing tape until the sill pan is covered to the interior sill pan lip.

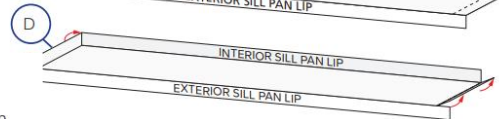
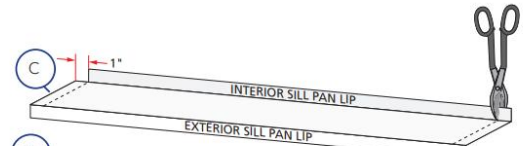
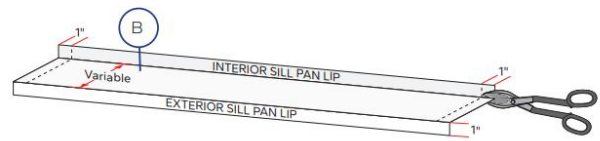

flush with

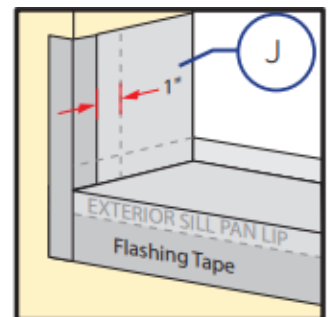
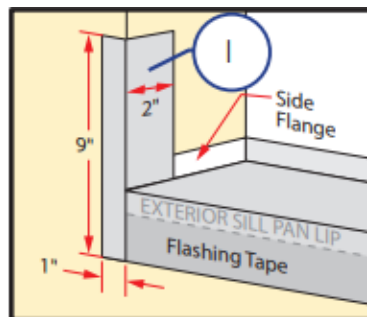
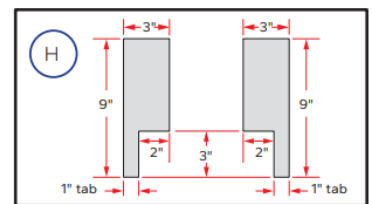
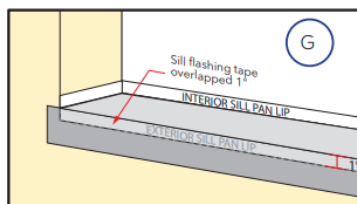
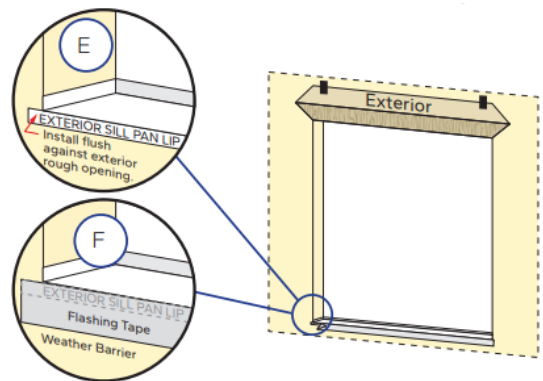

NOTE: The purpose of this tape is to seal the sill screws when installing the door.

H. Cut two 9" pieces of flashing tape with a 1" x 3" tab at the bottom, on the opposite corners as shown.

I. Apply the tabbed 9" pieces of flashing tape. The tape is applied so 2" will cover the inside of the rough opening and lap over the side flange of the sill pan. The 1" x 3" tab laps over the bottom flashing tape as shown.

J. Cut two 6" pieces of flashing tape and apply to each side of the rough opening, overlapping the first piece by 1" and lapping the bottom over the side flange of the sill pan as shown.

K. Cut two pieces of flashing tape 1-1/2" x 6" and apply to the bottom corners of the opening by beginning in the corner of the sill pan, with 3/4" of the tape applied to the sill pan and 3/4" of the tape applied to the side flange. The remainder of the tape is to be at a 45 degree angle onto the exterior.

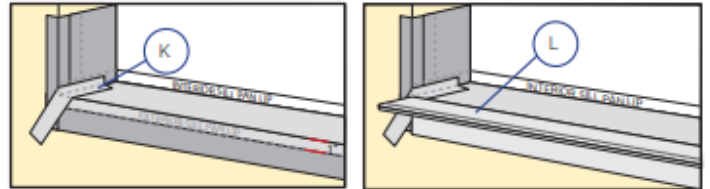

L. Attach the aluminum sill support or wood blocking to the exterior of the box plate to support the edge of the door sill. Place the sill support flush with the subfloor

Concrete Slab (without sill pan) Instructions

NOTE: Thoroughly clean the slab where sealants will be installed. Instead of installing flashing tape across the bottom of the rough opening, complete the following:

A. Install flashing tape at the bottom 6" of the rough opening jambs.

B. Cut two 9" pieces of flashing tape as shown in step 1H above.

C. Install them overlapping the flashing tape installed in step A by 1".

D. Place a 3/8" bead of sealant where the bottom edge of the flashing tape meets the concrete slab.

E. When folding building wrap in at the jambs, cut at a 30 degree angle as illustrated.

Follow the applicable installation method pages to complete the installation except seal the door sill directly to the slab.

