











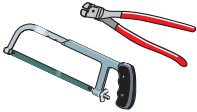





WINDOW WITH FIN COMBINATION ASSEMBLY INSTRUCTION USING 1/2" MULLION REINFORCEMENT

Note: This process is approved for combinations assembled by Pella Sales Branch professionals only.

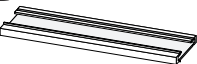
TOOLS REQUIRED:

- Tape measure 
- Hammer or air staple gun 
- Corner notching tool or hacksaw 
- Rubber mallet 
- Drill 

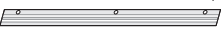
YOU WILL NEED TO SUPPLY:

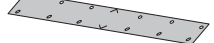
- High quality exterior grade polyurethane 
- 1" x 3/4" staples 
- 1-1/2" head sealant tape 
- 1/2" mullion reinforcement 
- 1/2" mullion covers 
- Mullion end splice 
- Mullion anchor brackets 
- Nailing fins 
- Fin corners 
- Head drip cap 
- Shipping plates 

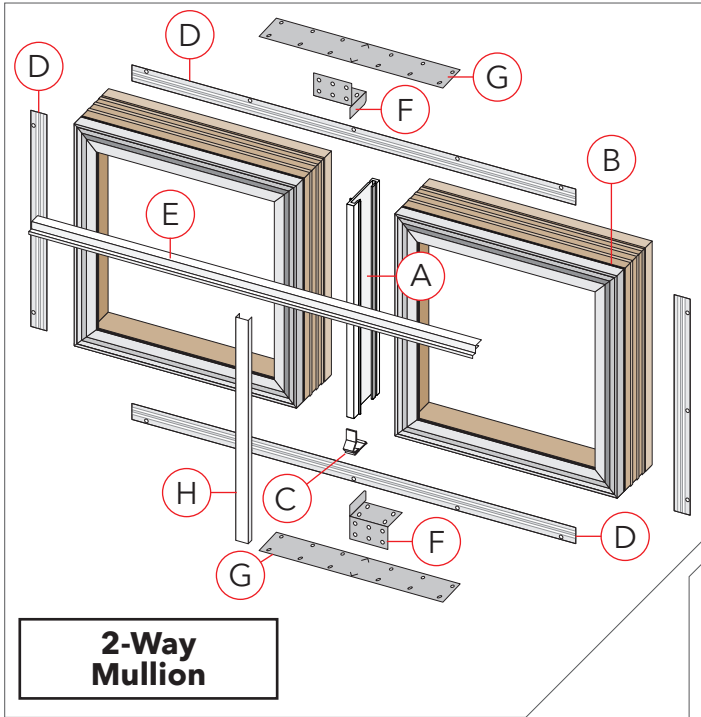

REMEMBER TO USE APPROPRIATE PERSONAL PROTECTIVE EQUIPMENT.

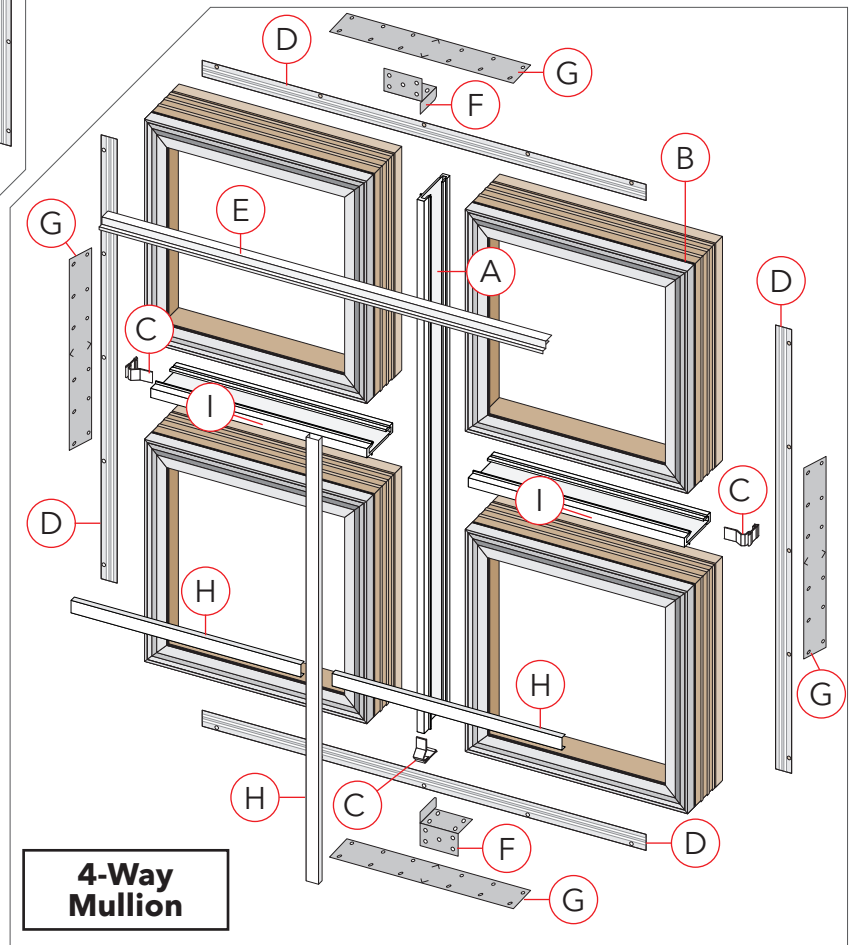

LEGEND:

- A. Mullion reinforcement
- B. Fin groove
- C. Mullion end splice
- D. Nailing fin
- E. Head drip cap
- F. Mullion anchor bracket
- G. Shipping plate
- H. Mullion cover
- I. Intermediate mullion reinforcement



Always read the Vinyl Window and Door Limited Warranty before purchasing or installing Vinyl Windows and Doors manufactured by Pella Corporation. By installing this product, you are acknowledging that this Limited Warranty is part of the terms of the sale. Failure to comply with all Pella installation and maintenance instructions may void your Pella product warranty. See written Limited Warranty for details, including exceptions and limitations at pella.com/warranty, or contact Pella Customer Service at 877-473-5527.

Note: For standard intermediate mullions (without 1/2" reinforcement) refer to *Standard Mullion Instructions*. For reinforced intermediate mullions, proceed to **Step 1 - Mulling Intermediate Combinations**.

Note: If you are assembling a 2-way reinforced mullion (two units mullied together, either side by side or one above the other) proceed to **Step 2 - Continuous Mullion Assembly**.

1 MULLING INTERMEDIATE COMBINATIONS

- A. **Cut a piece of mullion reinforcement** 1/2" shorter than the window.
- B. **Place a 3/8" continuous bead of sealant** down the fin groove and interior frame step of the window.

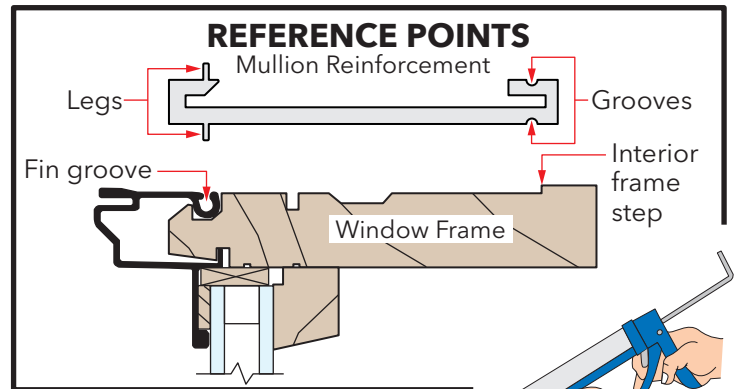

- C. **Position the mullion reinforcement as shown in the REFERENCE POINTS**, center on the window and press the leg into the fin groove. **Note:** A space of 1/4" from the edge of the window to the end of the mullion reinforcement is required to allow for fin placement.

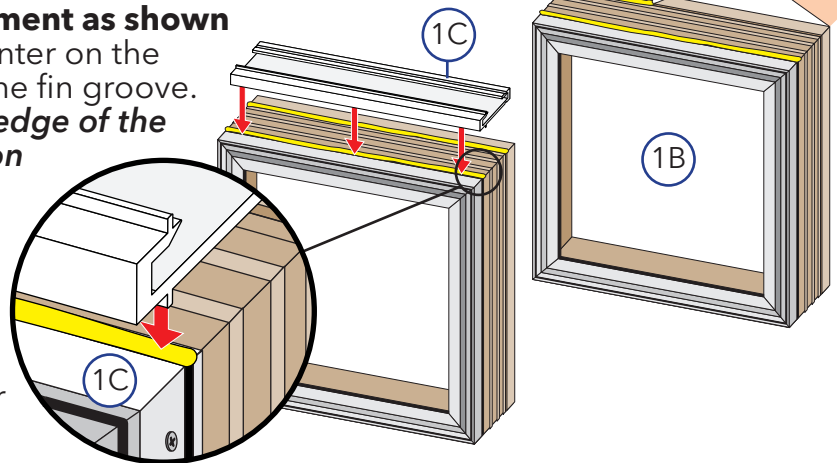

- D. **Place a continuous bead of sealant** on the second window, down the fin groove and interior frame step.

- E. **Place the second window onto the mullion reinforcement.** Line up the leg on the mullion reinforcement with the fin groove of the second window and press into place.

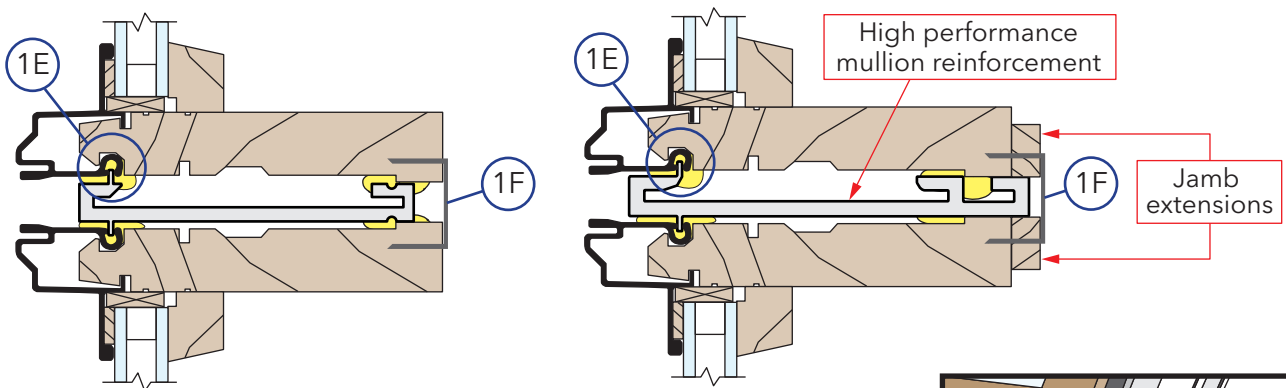

- F. **Attach the windows together on the interior using 1" x 3/4" staples.**

- G. **Using a corner notching tool or hacksaw, notch corners** wherever a mullion cover, head drip fin or frame expander will run through a joint.

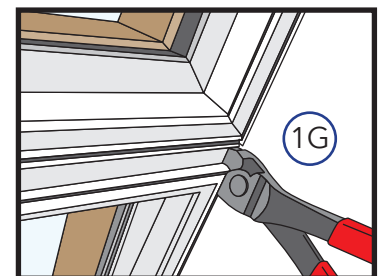

H. **Cut a piece of mullion cover 5/8" shorter than the window**, center on combinations and use a rubber mallet to snap the mullion cover in place.

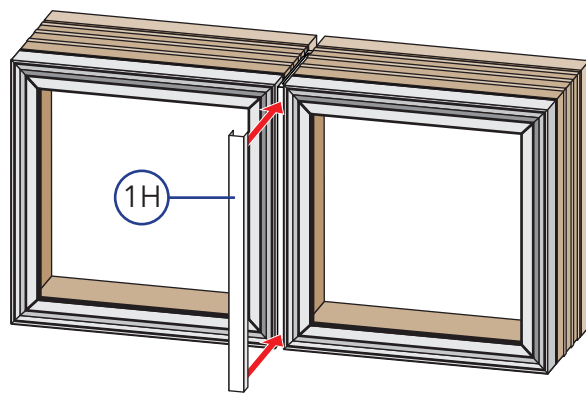

2 CONTINUOUS MULLION ASSEMBLY

This step is for continuous mullion application, where sub-combinations or single windows are mullied together using continuous mullions.

A. **Prepare sub-combinations** according to the instructions in Step 1 - MULLING INTERMEDIATE COMBINATIONS.

B. **Place a 3/8" continuous bead of sealant** down the fin grooves and interior frame steps of the window.

C. **Cut and install a piece of mullion reinforcement 1/2" shorter than the window or sub-combinations.**

Orientate the mullion reinforcement as shown in the REFERENCE POINTS, center on the sub-combinations and press the leg into the fin groove.

Note: A space of 1/4" from the edge of the sub-combination to the end of the mullion reinforcement is required to allow for fin placement.

D. **Place a 3/8" continuous bead of sealant** on the second window or set of sub-combinations, down the fin grooves and interior frame steps.

E. **Place the second window or set of sub-combinations onto the mullion reinforcement.** Line up the leg on the mullion reinforcement with the fin groove of the second window or set of sub-combinations and press into place.

F. **Attach the windows together on the interior using 1" x 3/4" staples.**

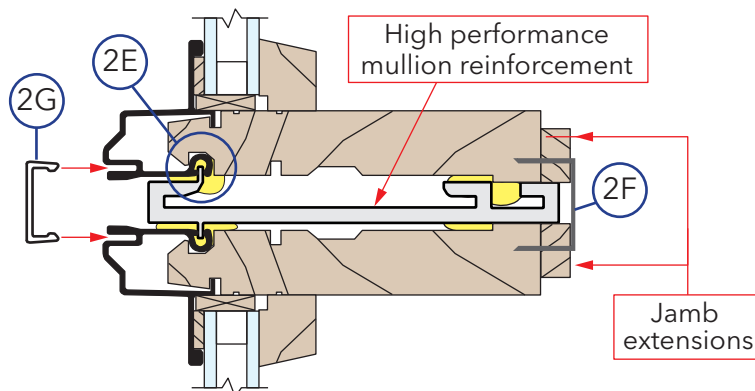
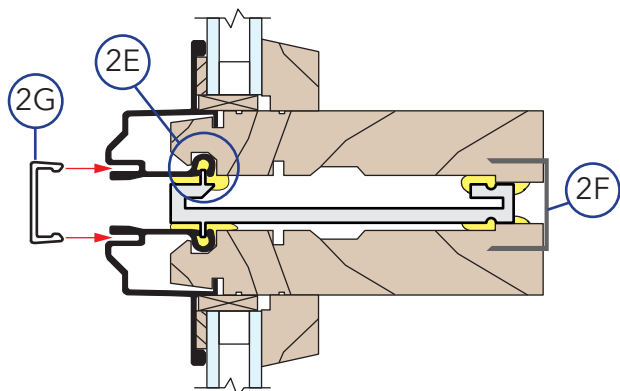
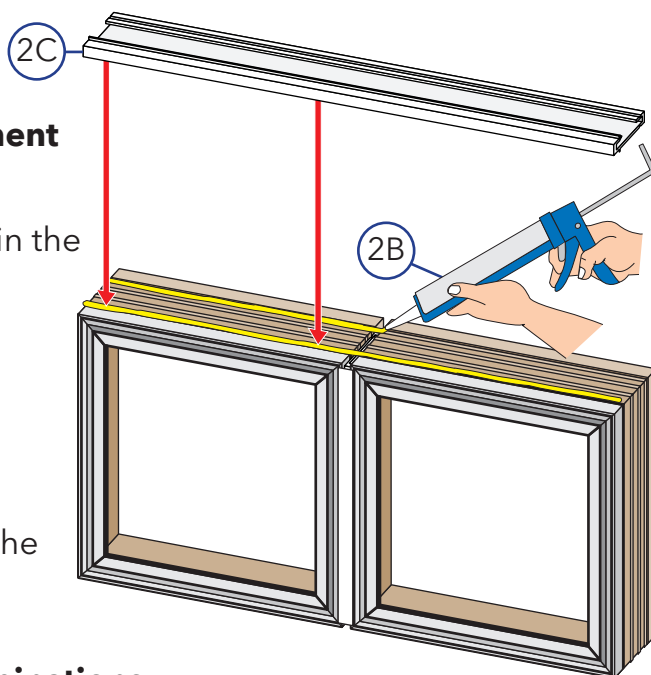

G. **Cut a piece of mullion cover 5/8" shorter than the combinations**, center on combinations and use a rubber mallet to snap the mullion cover in place.

3 COMPLETING THE COMBINATION ASSEMBLY

- A. **Cut a 1/2" piece of mullion end splice** for each horizontal and the bottom of each vertical mullion joint.
- B. **Fill the end of the mullion joints with sealant and attach the mullion end splices**, lined up with the adjacent windows.
- C. **Install continuous nailing fins** around the combination.
- D. **Attach the fin corners.**
- E. **Fill all head end joints with sealant.**
- F. **Apply 1-1/2" head sealant tape**, lapping the tape onto the fin at least 1/2".
- G. **Cut the head drip cap** to the width of the combination and press the leg of the cap into the accessory groove of the combination.
- H. **Tape over the joint** between the head fin and head drip cap with 1-1/2" head sealant tape.

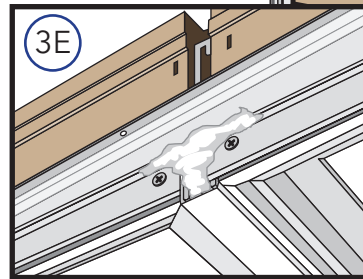
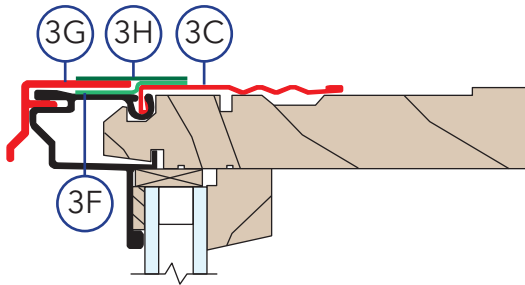
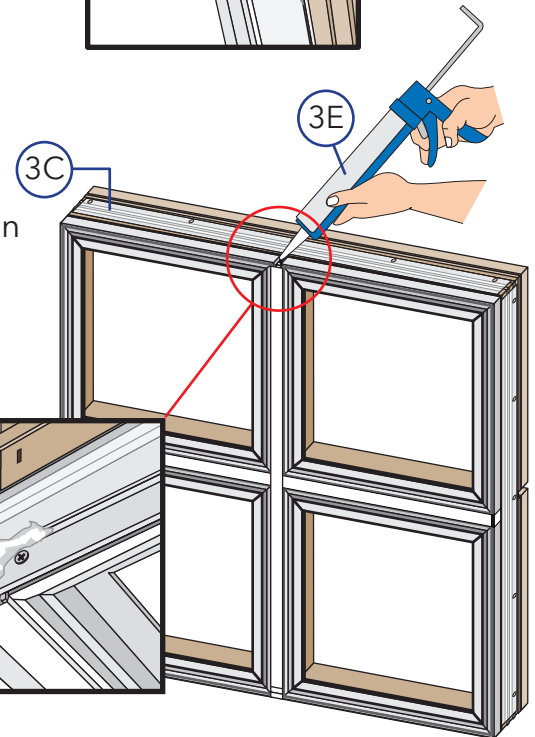
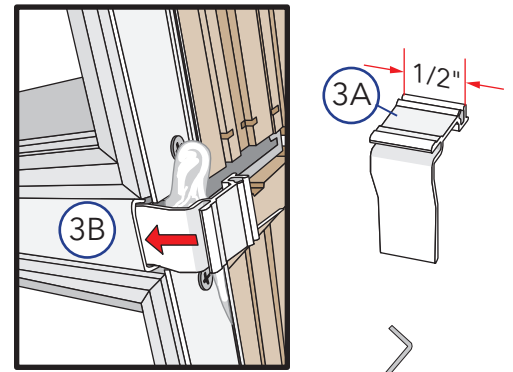

- I. **Fold the nailing fins up** and insert the head and sill mullion anchor brackets.
Note: Do not attach the mullion anchor bracket with screws at this time.
- J. **Attach the shipping plate to the mullion combination** by aligning the arrows on the plate with the mullion joints and driving ten #6 x 5/8" flat head screws (provided) to secure.
Note: When installing the shipping plate at the head and sill, two of the holes on the mullion anchor bracket will align with holes in the shipping plate. Secure the mullion anchor bracket in place using the two exposed holes.
- K. **Package the combination assembly** for shipping and handling to the job site.
Note: Wood blocking behind the fin is recommended to support the fin and prevent damage.

