



**General Information**

Introduction ..... F-COMB-2

**Combination Assembly Recommendations and Limitations**

Design Considerations and Examples..... F-COMB-3
Single-Unit Opening Recommendations ..... F-COMB-6
Typical Sealant Recommendations..... F-COMB-6
Two-Way Joint Recommendations
Horizontal Window Combinations..... F-COMB-7
Vertical Window Combinations ..... F-COMB-8
Three-Way Joint Recommendations ..... F-COMB-9
Four-Way Joint Recommendations ..... F-COMB-10
Door to Door and Window to Door Recommendations ..... F-COMB-11
Vertical Window Mullion Component Parts and End Anchors ..... F-COMB-12
Horizontal Window Mullion Component Parts and End Anchors..... F-COMB-13
Vertical Door Mullion Component Parts and End Anchors..... F-COMB-14
Horizontal Door Mullion Component Parts and End Anchors..... F-COMB-15
Combination End Anchor Capacities..... F-COMB-16
Typical Combinations - Sample Calculations..... F-COMB-17
Mullion Load Charts
Two-Way Mullion of any Combination of Rectangle Windows ..... F-COMB-20
Three-Way Mullion of any Combination of Rectangle Windows ..... F-COMB-22
Four-Way Mullion of any combination of Rectangle Windows ..... F-COMB-24
Two-Way Mullion of Rectangle Window to Special Shape ..... F-COMB-26
Three-Way Mullion of 2 Rectangle Windows to Special Shape ..... F-COMB-28
Two-Way Mullion, Vertical Door to Door..... F-COMB-30
Two-Way Mullion, Horizontal Door to Rectangle Transom..... F-COMB-31
Two-Way Mullion, Horizontal Door to Shape Transom ..... F-COMB-33
Three-Way Mullion, Door to Two Transoms, Horizontal Structure ..... F-COMB-34
Four-Way Mullion, Two Doors to Two Transoms Horizontal Structure ..... F-COMB-36
Four-Way Mullion, Two Doors Mullied to Two Transoms Vertical Structure ..... F-COMB-38

**Supporting documents for this product:**

CAD cross sections (requires appropriate CAD software to read and use):

Door Reinforcing Mullions

[https://media.pella.com/professional/adm/Fiberglass/F2DrComboMul\\_D.dwg](https://media.pella.com/professional/adm/Fiberglass/F2DrComboMul_D.dwg)

[https://media.pella.com/professional/adm/Fiberglass/F2DrComboMul\\_D.dxf](https://media.pella.com/professional/adm/Fiberglass/F2DrComboMul_D.dxf)

Window Reinforcing Mullions

[https://media.pella.com/professional/adm/Fiberglass/F2WdwComboMul\\_D.dwg](https://media.pella.com/professional/adm/Fiberglass/F2WdwComboMul_D.dwg)

[https://media.pella.com/professional/adm/Fiberglass/F2WdwComboMul\\_D.dxf](https://media.pella.com/professional/adm/Fiberglass/F2WdwComboMul_D.dxf)



This section explores the opportunities, requirements and limitations related to joining various combinations of standard Pella® Impervia® windows and doors.

**Important:**

Determining and meeting the structural load requirements and design of the rough opening is the responsibility of the architect or engineer. Window and door frame systems are not designed to support additional elements or components of the building wall system.

Specific accessories and construction details must address the various conditions that are critical for the proper design of a horizontal combination of windows (ribbon windows) and vertical combination (stacked windows) such as:

- Proper flashing
- Control joints to accommodate expansion and contraction
- Intermediate structural support
- Mullion reinforcing end anchorage
- Rough opening wall construction to accept loads transferred from window combination.

Definitions:	
<b>Combination</b>	An assembly formed by two or more separate windows, window composites, or doors whose frames are mullioned together using a combination joining mullion or reinforcing mullion.
<b>Standard Joining Mullion (Tight Mullion)</b>	A mulling method formed by joining two or more individual window or door units together without a mullion stiffener.
<b>Structural Mullion (Aluminum Mullion)</b>	A mulling method formed by joining two or more individual window or door units together with an added continuous aluminum mullion stiffener.
<b>Structural Mullion with Reinforcement (Aluminum Mullion)</b>	A mulling method with an added continuous aluminum mullion stiffener including a continuous steel plate reinforcement insert.
<b>Composite</b>	A window or door consisting of two or more sash in one frame utilizing an integral mullion. See individual product sections for min/max and composite square ft validation.
<b>Integral Mullion</b>	A horizontal or vertical member which is bounded at either end or both ends by a crossing frame member.



The following steps are provided as a guide to help the designer properly integrate Pella products and accessories in combination assemblies. Sample calculations based on these steps are included later in this document.

**1. Determine the overall size and configuration of the combination.**

The following page shows the basic combination assembly types. Windows or doors within the combination can be fixed or venting.

**2. Determine the required wind load (design pressure).**

The design pressure is the wind load pressure that the window assembly is to withstand. The design pressure should be determined by the project engineer or architect but can also be provided by the local code official.

ASCE 7, Minimum Design Loads for Buildings and Other Structures, contains the generally accepted method for determining design pressure for components and cladding based on building size and shape, geographical location, topographical factors, building use and location on the building's surface.

**3. Determine if the individual windows and/or doors within the assembly meet the required design pressure.**

Each Pella window and door is rated to withstand a certain level of wind loading. The design pressure determined in step 2 should also be used to specify window and door performance. The Performance section of this manual provides more detailed information on the relationship between design pressure and the performance class and grade ratings used to specify window/door performance. See each product section in this manual to determine if each window or door can withstand the required design pressure.

**4. Determine if the glazing within each product can withstand the required design pressure.**

ASTM E 1300-16 requires that glazing be of adequate strength to resist excessive deflection under wind load. Select the appropriate glazing type and/or thickness required to meet the design pressure. Your local Pella sales representatives can utilize the Pella quoting system to assist in determining the glazing design pressure of a specific product.

**5. Determine if the combination will be factory assembled or non-factory assembled.**

Use the combination size tables and Factory Assembled Window Combination Configuration Rules found in this section to determine if the combination is available factory assembled. If it is not found in the size tables, it is not available from the factory. Also consider factors such as installation method, handling and accessibility to the opening. Conditions specific to the project may require that a combination be assembled at the job-site or in the opening.

**6. Determine the requirement for spread or reinforcing mullions.**

Placing windows and doors in an assembly creates joints or mullions that may need reinforcing and/or flashing requirements. In order to ensure that a given combination will withstand the design pressure determined in step 2, use the mullion joint load tables starting on page 17. These tables are organized by joint type. Use the graphical representation of each joint type to determine which joint type(s) are contained within the combination. The reinforcing tables consider structural performance only. Performance class and grade ratings apply to single units only. See the Size and Performance Data page within each product section for more information.

Also consider the dead load when placing window mullions over the clear opening space of vent windows or doors.

**7. Determine the appropriate reinforcing mullion.**

The mullion reinforcing tables in this section are intended to aid in the selection of reinforcing members to help the assembly resist the forces placed upon it by wind loads and loads caused by other units within the combination. Page 14 provides instruction on how to use the tables. By entering the tables with the joint's mullion length and the widths of the adjacent units, choose any mullion reinforcing option at or below the coordinate given on the table. If spread mullions are desired for aesthetic reasons, use the tables to determine if the spread mullion is sufficient.

**8. Determine actual rough opening size and window/door data.**

This section contains recommendation pages for each assembly type. Use the recommendations in this section to determine rough opening clearance dimensions as well as if subsill is required. Add any applicable frame, accessory, and mullion dimensions to arrive at the overall opening dimensions.

The combination assembly design example later in this document shows how these steps can be followed to design a combination assembly.



### Impervia Factory Assembled Window Combination Configuration Rules

1. Factory Assembled Combination width and height maximum is 143.5" x 105.5" (block frame no fin) and 138.5" x 101" (block frame with standard and offset fin) with a total of 80 square feet and 500 lbs. maximum.
2. These combinations not allowed.

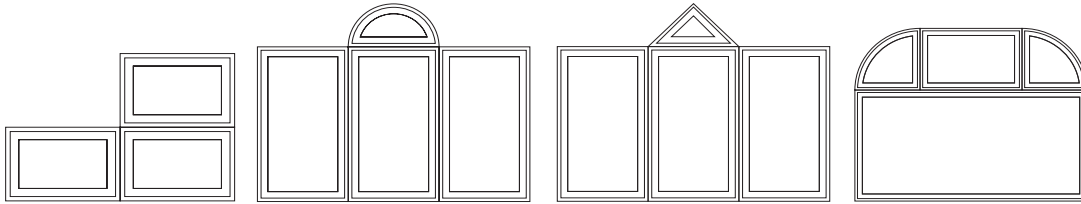

3. All mullions must pass through mullion validation rules.
4. If the combination has more than 2 units, base frame depth cannot vary within a row and column (see diagram below).
5. DH's may not be mulled over other units using an aluminum mullion
6. All slopes (curved or straight) must continue to the end(s) of the combination.
7. Integral fin units can not be mulled.
8. Field spread mulled combinations OR combinations configured for alignment purposes may not be restricted by these rules.

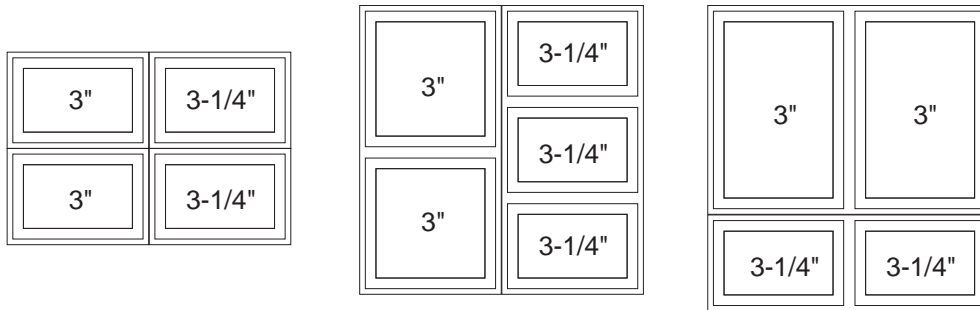

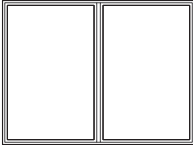
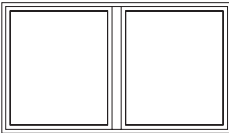
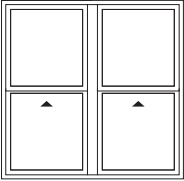
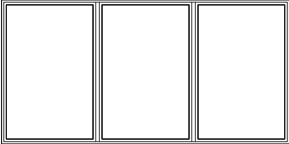
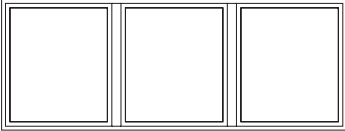
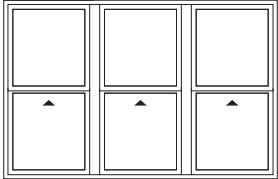
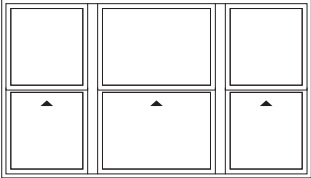
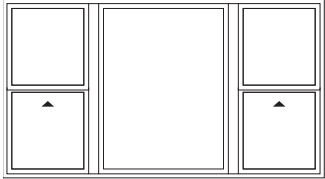
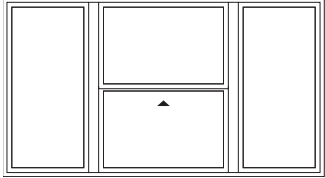

Pella Impervia composites are engineered to meet the performance class and grade shown in the design data tables in each product section. Composites are available in window types and configurations shown below. See the product sections for complete details.

Composite Configurations		
Fixed Frame Direct Set	Fixed Window	Single-Hung
 <p>2-Wide Composite with Integral Mullion</p>	 <p>2-Wide Composite with Integral Mullion</p>	 <p>2-Wide Vent Composite with Integral Mullion</p>
 <p>3-Wide Composite with Integral Mullion</p>	 <p>3-Wide Composite with Integral Mullion</p>	 <p>3-Wide (Equal) Vent Composite with Integral Mullion</p>
		 <p>3-Wide (Unequal) Vent Composite with Integral Mullion</p>
		 <p>Fixed with Vent Flankers Composite with Integral Mullion</p>
		 <p>Vent with Fixed Flankers Composite with Integral Mullion</p>



### Typical Sealant Recommendations

Proper sealant placement is critical to window or door performance. See typical exterior and interior perimeter sealant details below.

#### Interior and Exterior Sealant Placement Detail

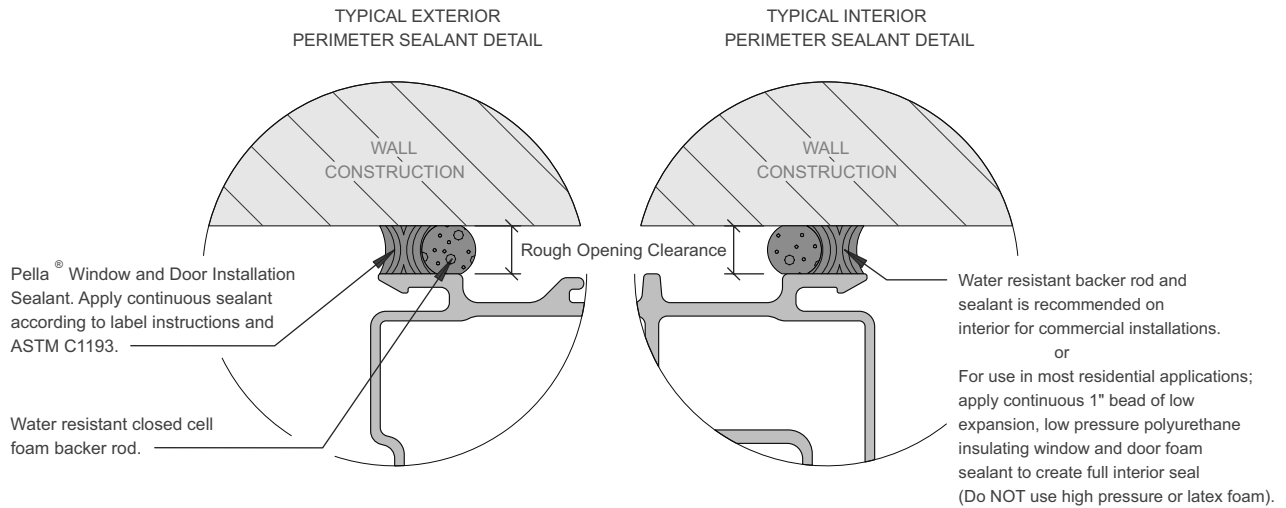

Recommended Rough Opening clearance shown above for a single window is 1/4" (1/2" total).  
For combinations clearance should be 3/8" (3/4" total), for large combinations 1/2" (1" total).

When applying siding, brick veneer, stucco or other exterior finish material, leave adequate space between the unit frame and the exterior finish material for backer rod and sealant.

**Note:** The sealant details shown are standard recommendations from the sealant industry. Contact your sealant supplier for recommendations and instruction for this or any other application.

### Single Unit Opening Recommendations

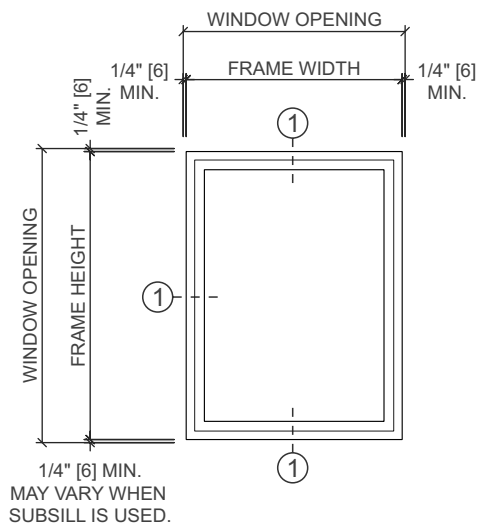

① To determine window openings for typical installations, add twice the rough opening clearance to the frame width and frame height. For large size units, openings with build up of multiple flashing materials, and/or in masonry construction, the need for additional rough opening clearances should be reviewed.

Typical installation details and accessories are shown in the Installation Details section.

Determine if unit performance meets design requirements. Unit performance limitations are in each product section.

See typical exterior and interior perimeter sealant details above. Proper sealant placement is critical to window performance.

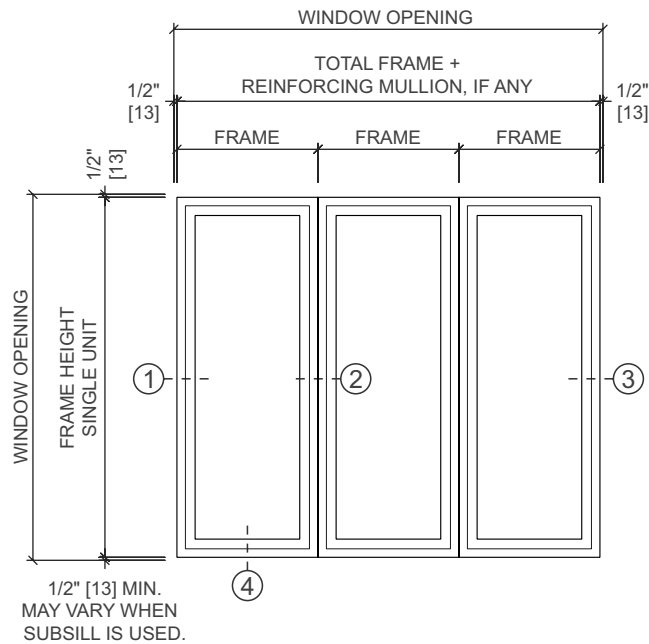

These recommendations apply to a typical horizontal combination of any vent or fixed unit of the same height to a maximum width of 20' without an expansion mullion.

Refer to single-unit opening recommendations in addition to the following:

- ① Minimum 3/8" clearance on smaller combination openings (See rough opening recommendations earlier in this section).
- ② Check if mullion reinforcement is required due to specified wind loading. (See mullion load charts later in this section).
- ③ Minimum 1/2" clearance is recommended at each jamb for openings with three or more windows.
- ④ Subsill systems that weep incidental moisture to the exterior are recommended for water management in openings where the potential for water infiltration is increased and may not be adequately managed by the building weather barrier, flashings and drainage system. Sample conditions include, but are not limited to: increased level of exposure due to multi-story construction, high weather exposure, recaulking would be difficult or unlikely, non-standard installation methods, or when there are multiple units joined within the opening.

Proper sealant placement is critical to window performance.



Vertical Window Combinations - Two-Way Horizontal Joint Recommendations

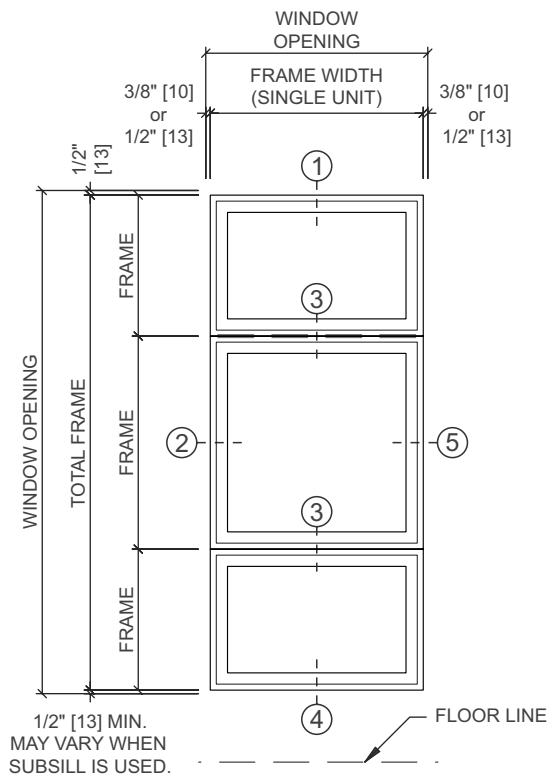

These recommendations apply to typical vertical stacking of vent or fixed units of the same width to a maximum height of 20' without intermediate support and expansion mullion cover.

Refer to single-unit opening recommendations in addition to the following:

- ① Intermediate dead load support is required as needed.
- ② 1/2" rough opening clearance is recommended for construction tolerances in large combinations.
- ③ Check if reinforcing mullion is required due to specified wind loading and dead load (See mullion load charts later in this section).
- ④ Subsill systems that weep incidental moisture to the exterior are recommended for water management in openings where the potential for water infiltration is increased and may not be adequately managed by the building weather barrier, flashings and drainage system. Sample conditions include, but are not limited to: increased level of exposure due to multi-story construction, high weather exposure, re-caulking would be difficult or unlikely, non-standard installation methods, or when there are multiple units joined within the opening.
- ⑤ Pella® Impervia® windows require stacked units to be mullied together using proper combination mullion accessories prior to placing the windows in the rough opening. Practical consideration should be given to limiting the quantity of stacked units within a given height to an amount that can be safely handled by the installer without damage to the units and mullion integrity. The recommended number of units per stack is three or less.

Proper sealant placement is critical to window performance.



## Three-Way Window Joint Recommendations

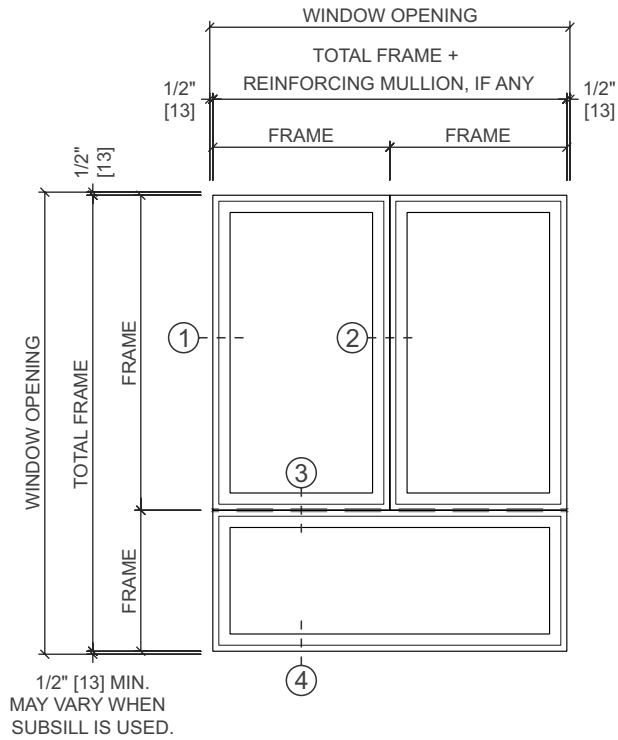

These recommendations apply to a typical grouping of any two vent or fixed units over one fixed unit that forms a three-way mullion intersection.

Refer to single-unit opening recommendations in addition to the following:

- ① 1/2" rough opening clearance is recommended in masonry construction and/or large combinations.
- ② Reinforcing mullion (see chart) or integral mullion (see product section for performance).
- ③ Reinforcing mullion is required due to specified wind loading (See mullion load charts later in this section). Check both 2- and 3-way mullions.
- ④ Subsill systems that weep incidental moisture to the exterior are recommended for water management in openings where the potential for water infiltration is increased and may not be adequately managed by the building weather barrier, flashings and drainage system. Sample conditions include, but are not limited to: increased level of exposure due to multi-story construction, high weather exposure, re-caulking would be difficult or unlikely, non-standard installation methods, or when there are multiple units joined within the opening.

Proper sealant placement is critical to window performance.



## Four-Way Window Joint Recommendations

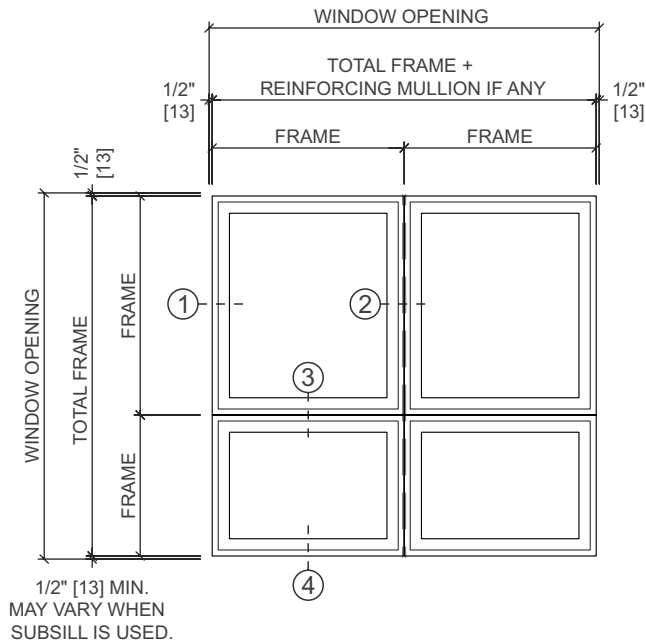

These recommendations apply to a typical grouping of any combination of window units that form a four-way mullion intersection.

Refer to single-unit opening recommendations in addition to the following:

- ① 1/2" rough opening clearance is recommended in masonry construction and/or when multiple units are installed within the same opening.
- ② All four-way mullion intersections require reinforcing mullion in one direction (either vertically or horizontally, see mullion load charts later in this section).
- ③ Check two way combination mullion limitation for specified wind loading or Product section for composite with integral mullion.
- ④ Subsill systems that weep incidental moisture to the exterior are recommended for water management in openings where the potential for water infiltration is increased and may not be adequately managed by the building weather barrier, flashings and drainage system. Sample conditions include, but are not limited to: increased level of exposure due to multi-story construction, high weather exposure, recaulking would be difficult or unlikely, non-standard installation methods, or when there are multiple units joined within the opening.

Proper sealant placement is critical to window performance.



1. 1/2" clearance is recommended at the head of all doors.
2. 1/2" clearance is also recommended in masonry construction or large combinations.
3. Horizontal reinforcing mullion may be required above venting doors to carry weight of upper units and stiffen the mullion against wind loading.
4. Mullion intersections may require reinforcing mullion for two-way joints, reference mullion load charts later in this section.
5. Field framing may be required between Pella Impervia windows and door jambs, reference mullion load charts later in this section.

Proper sealant placement is critical to window and door performance.

### Typical Configurations

#### Typical Window Combinations

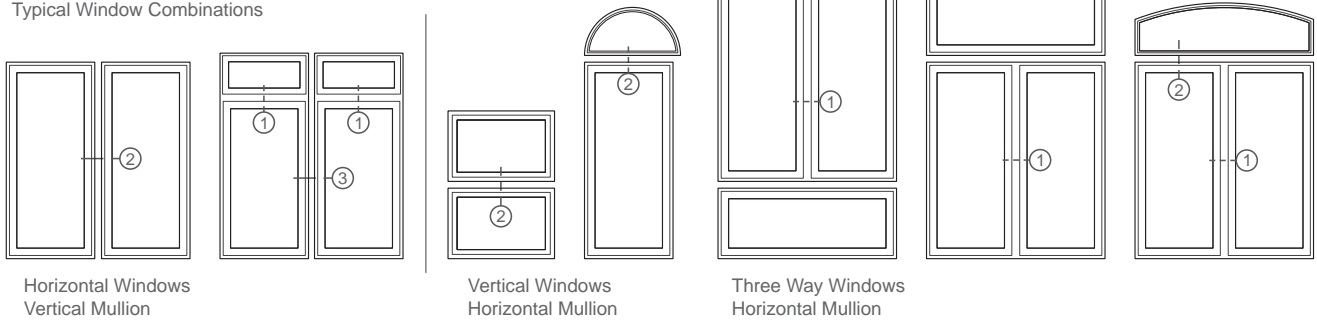

#### Typical Door Combinations

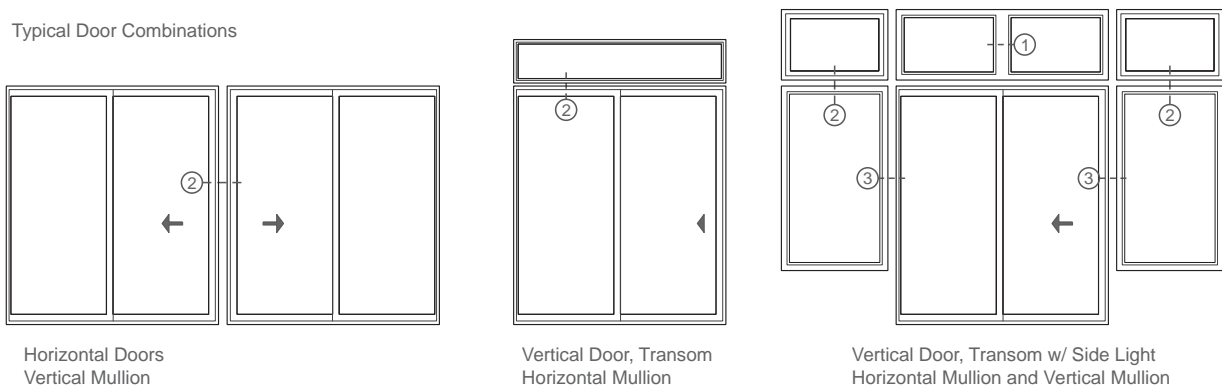

- ① Integral Mullion (Composite)
- ② Combination (Joining) Mullion or Reinforcing Mullion
- ③ Reinforcing Mullion Required



# Impervia® Combinations

## Vertical Window Mullion Component Parts and End Anchors

### (A1) - HEAD DRIP CAP

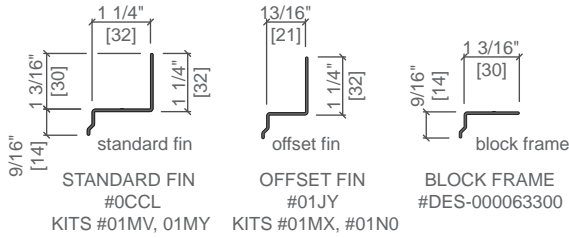

### (R1) - STRUCTURAL MULLION

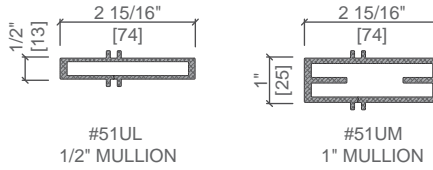

### (R3) - REINFORCEMENT

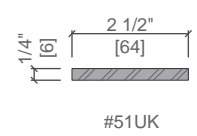

### (A2) - MULLION SPLICES

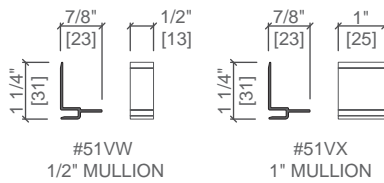

### (R2) - MULLION END ANCHORS

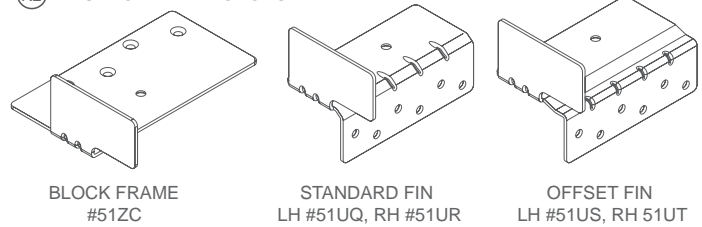

### (A3) - FOAM PLUGS

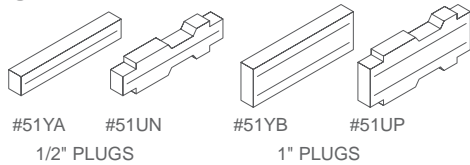

### (C1) - EXTERIOR MULLION COVERS



### (C2) - INTERIOR MULLION COVERS

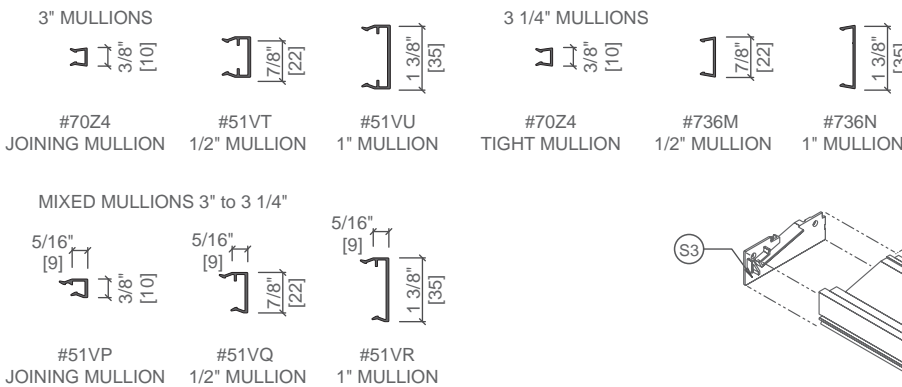

### (S1) - SUBSILL

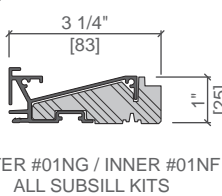

### (S2) - INTERIOR CLIP

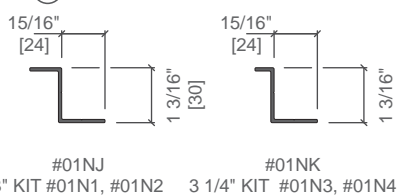

### (S3) - LEFT END CAP

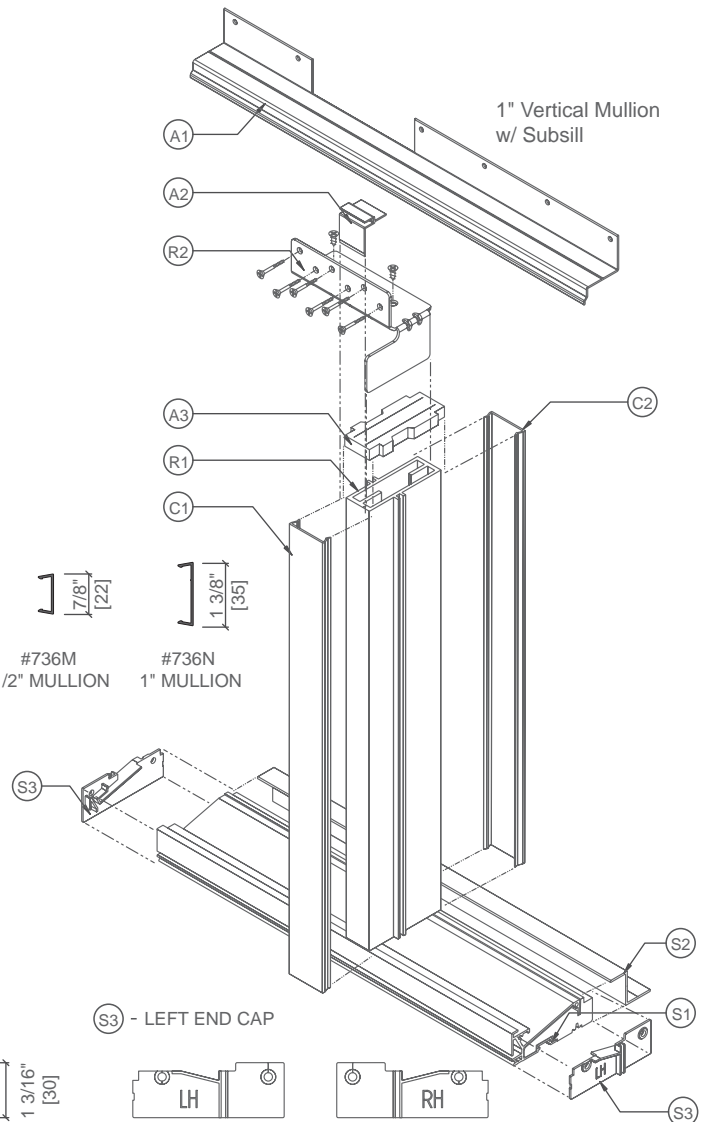
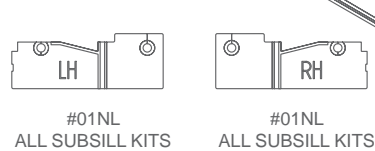



# Impervia® Combinations

## Horizontal Window Mullion Component Parts and End Anchors

### A1 - HEAD DRIP CAP

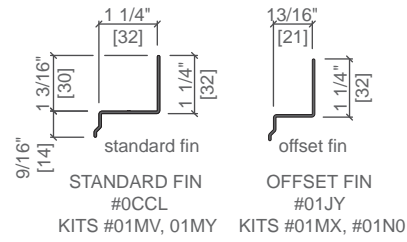

### A2 - MULLION SPLICES

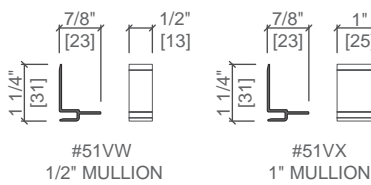

### A3 - FOAM PLUGS

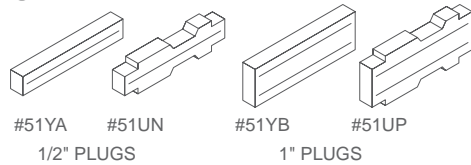

### C1 - EXTERIOR MULLION COVERS



### C2 - INTERIOR MULLION COVERS

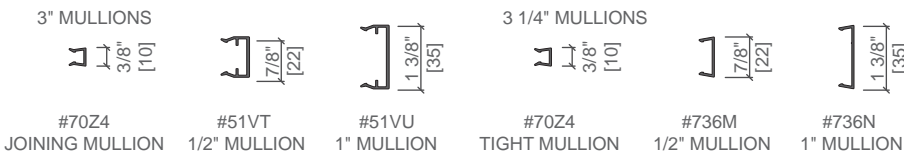

### MIXED MULLIONS 3" to 3 1/4"

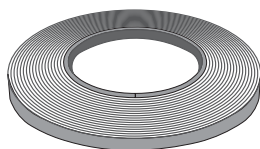
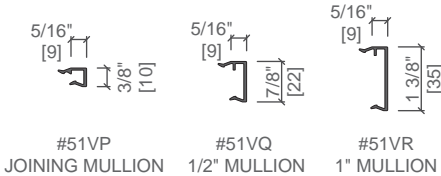

FOAM TAPE  
#0CDZ

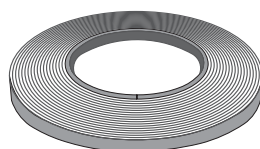

MULLION BUTYL TAPE SEAL - 30' ROLL  
#01JX

### R1 - STRUCTURAL MULLION

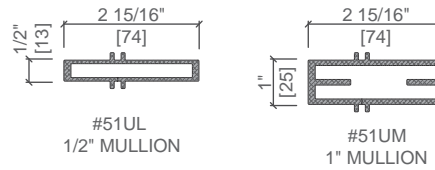

### R2 - MULLION END ANCHORS

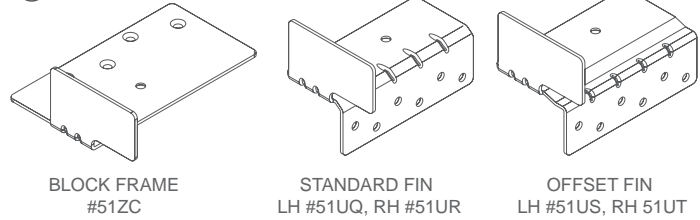

### R3 - REINFORCEMENT

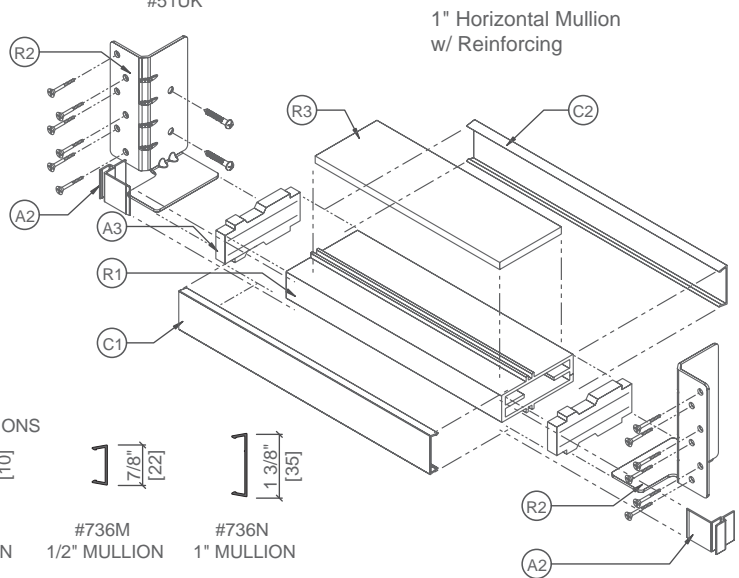
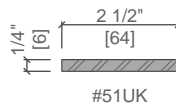

### WINDOW MULLING PLATES

SINGLE-HUNG / DOUBLE-HUNG / SLIDING WINDOW / FIXED WINDOW & FIXED FRAME

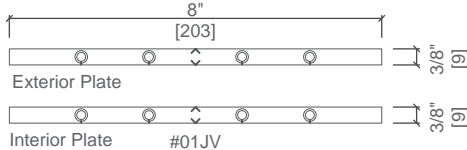

AWNING / CASEMENT

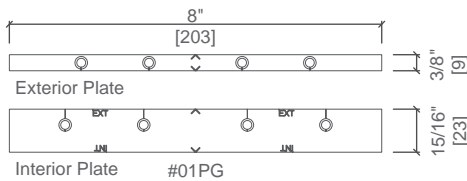



# Impervia® Combinations

## Vertical Door Mullion Component Parts and End Anchors

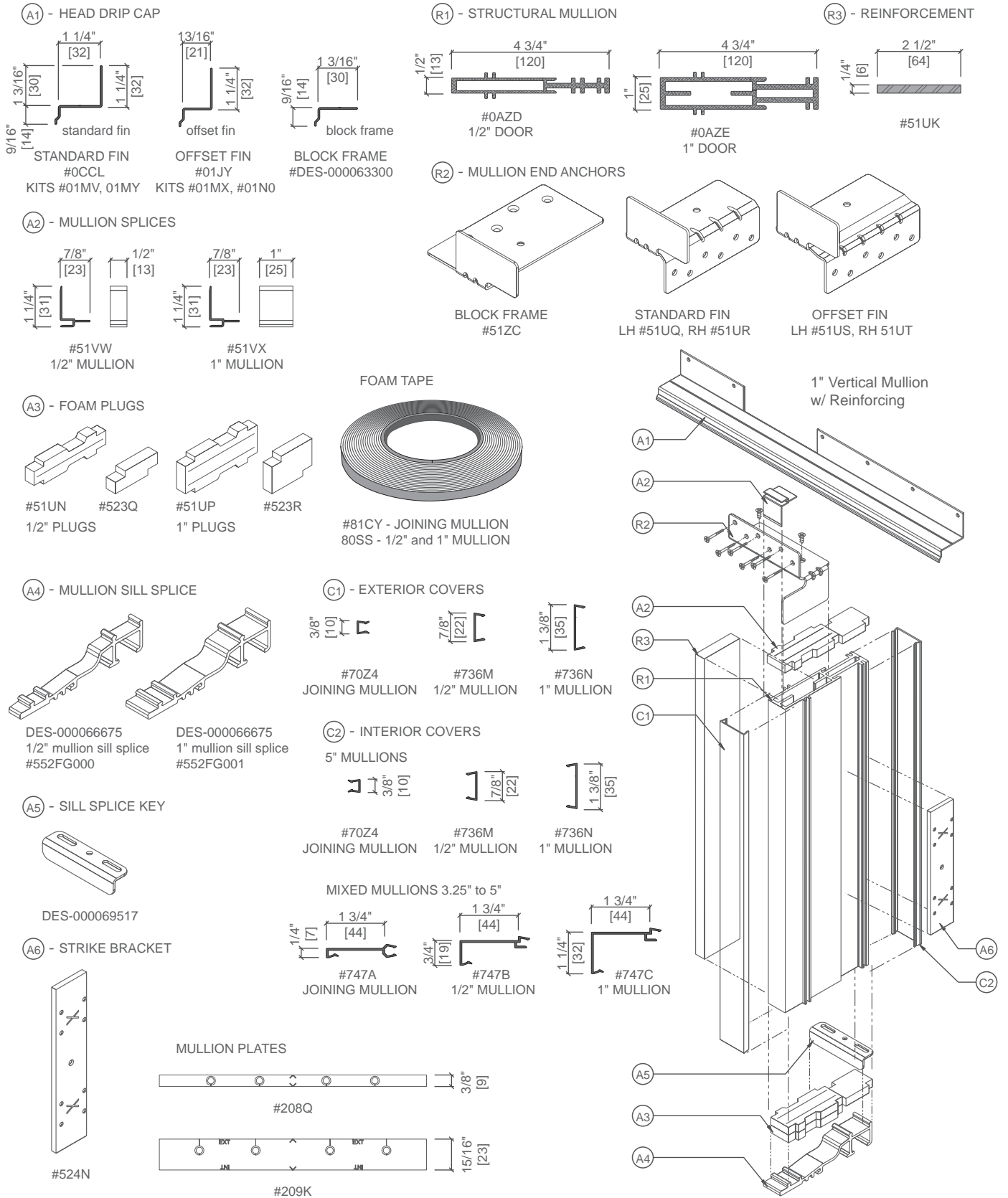



# Impervia® Combinations

## Horizontal Door Mullion Component Parts and End Anchors

### (A1) - HEAD DRIP CAP

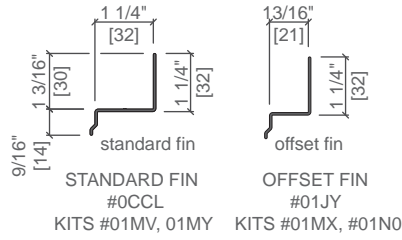

### (A2) - MULLION SPLICES

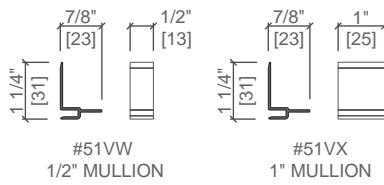

### (A3) - FOAM PLUGS

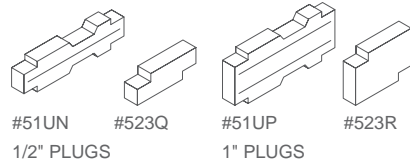

### (C1) - EXTERIOR COVERS



### (C2) - INTERIOR COVERS

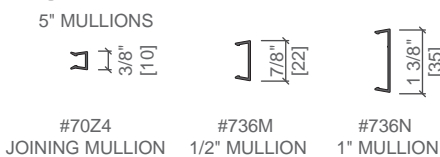

### MIXED MULLIONS 3.25" to 5"

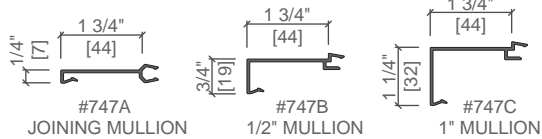

### MULLION PLATES

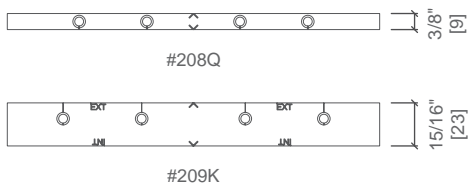

### (R1) - STRUCTURAL MULLION

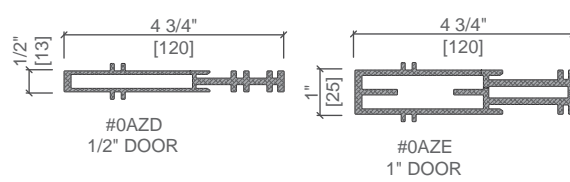

### (R2) - MULLION END ANCHORS

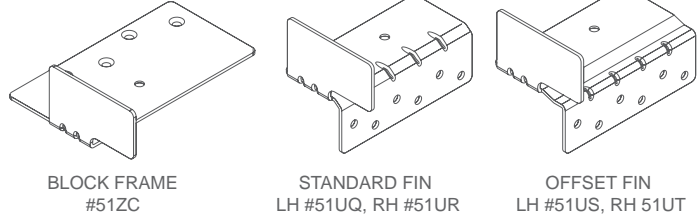

### (R3) - REINFORCEMENT

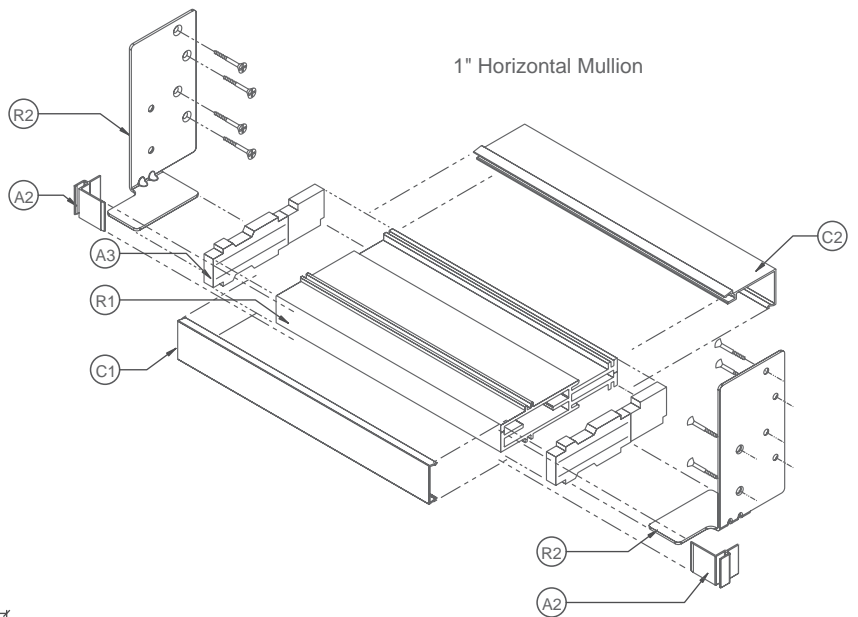
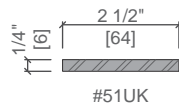

### FOAM TAPE

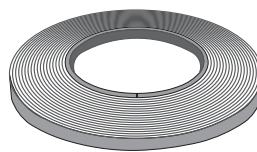

#81CY - JOINING MULLION  
80SS - 1/2" and 1" MULLION



# Impervia® Combinations

## Combination End Anchor Capacities

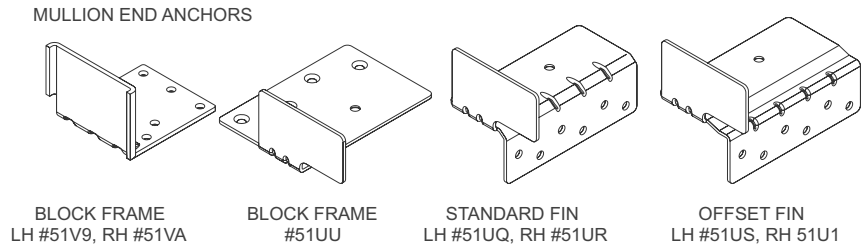

### Window and Door 1/2" & 1" Aluminum Structural Mullion Nail Fin and Offset Nail Fin End Anchors – 51UQ, 51UR, 51US, 51U1

Rough Opening Substrate	Maximum Qty of Fasteners	Type of Fastener	Capacity (lbs)
Wood	6	#8 Stainless Steel Wood Screw, 2" Embedment	1572
Light Gauge Steel (20 Ga.)	6	#10-16 Hex Washer Head Sheet Metal Screw, 3 embedded threads	504
Concrete	NA	Not Recommended	NA

### Window and Door 1/2" & 1" Aluminum Structural Mullion Block Frame End Anchor – 51UU

Rough Opening Substrate	Maximum Qty of Fasteners	Type of Fastener	Capacity (lbs)
Wood	4	#8 Stainless Steel Wood Screw, 2" Embedment	576
Light Gauge Steel (20 Ga.)	4	#10-16 Hex Washer Head Sheet Metal Screw, 3 embedded threads	708
Concrete	4	3/16" Tapcon-Type Screw Anchor, 1.25" embedment	596

### Window 1/2" & 1" Aluminum Structural Mullion Ribbon End Anchor (for assembly in the opening) – 51V9, 51VA

Rough Opening Substrate	Maximum Qty of Fasteners	Type of Fastener	Capacity (lbs)
Wood	7	#10 Stainless Steel Wood Screw, 2" Embedment	1246
Light Gauge Steel (20 Ga.)	7	#10-16 Hex Washer Head Sheet Metal Screw, 3 embedded threads	1239
Concrete	4	3/16" Tapcon-Type Screw Anchor, 1.25" embedment	420

Use the following to determine end anchors for Pella reinforcing options.

#### To Calculate End Load At Mullion Reinforcement:

$$\text{Load per end} = [(A + B) \times L \times P] / 2$$

A = Half the distance in feet from the mullion for which the loading is being figured to the next structural member to the left.

B = Half the distance in feet from the mullion for which the loading is being figured to the next structural member to the right.

P = Design wind load pressure required for the building project in pounds per square foot.

L = Mullion length in feet.



The following sample calculations are based on steps 1-8 on page 3.

1. Determine the overall size of the configuration of the combination or composite.

Product: Pella® Impervia® Fixed Frame Direct Set Window

- ① Integral Mullion
- ② Mullion type to be determined
- ③ Mullion type to be determined

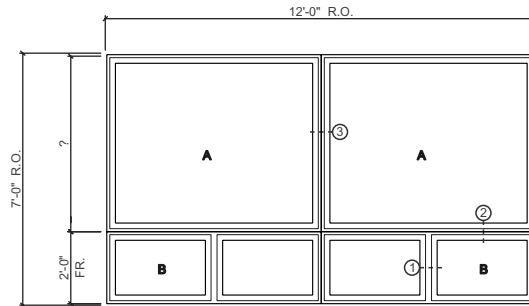

2. Determine the required windload (design pressure).

Project description:

- Location: Pella, IA
- Based on in ASCE 7-16, Minimum Design Loads for Buildings and Other Structures
- Wind speed = 109 mph, Exposure C
- Design Pressure: 25 psf

3. Determine individual window / door size and performance (nominal sizing).

Individual Window Performance: Unit A

- Project design pressure: 25 psf
- Required window / door performance class and grade rating: R25
- Applicable Product – Pella Impervia Fixed Frame Direct Set
- Individual window size and performance:
- Performance Class and Grade = CW-PG50
- Therefore selected windows meet design pressure requirements.

Individual Window Performance: Unit B

- Project design pressure: 25 psf
- Required window / door performance class and grade rating: R25
- Applicable Product - Pella Impervia 2-Wide Impervia Fixed Frame Direct Set Composite Window with Integral Mullion.
- Performance Class and Grade = CW-PG50

- ① - Integral Mullion
- Therefore selected windows meet design pressure requirements.

4. Determine glazing performance:

- Glazing performance is validated by using Pella Quote Management System.
- Requirements for glass thickness will vary depending on the size of the unit
- Selected window glazing must have sufficient load resistance to withstand the project design pressure requirements, per ASTM E1300.

5. Determine if the combination will be factory assembled or non-factory assembled.

For this example, portions of the window assembly are factory assembled and some are non-factory assembled.

6. Determine mullion types and reinforcement requirements:

- Windload (lateral loading) YES if yes, joint type: Joint ② = two-way joint  
Joint ③ = four-way joint
- Dead Load (above doors and awnings) Not Applicable.

Continued on next page



**7. Determine the appropriate mullion reinforcing:**

(See pages 3–6 in this section for notes and instructions)

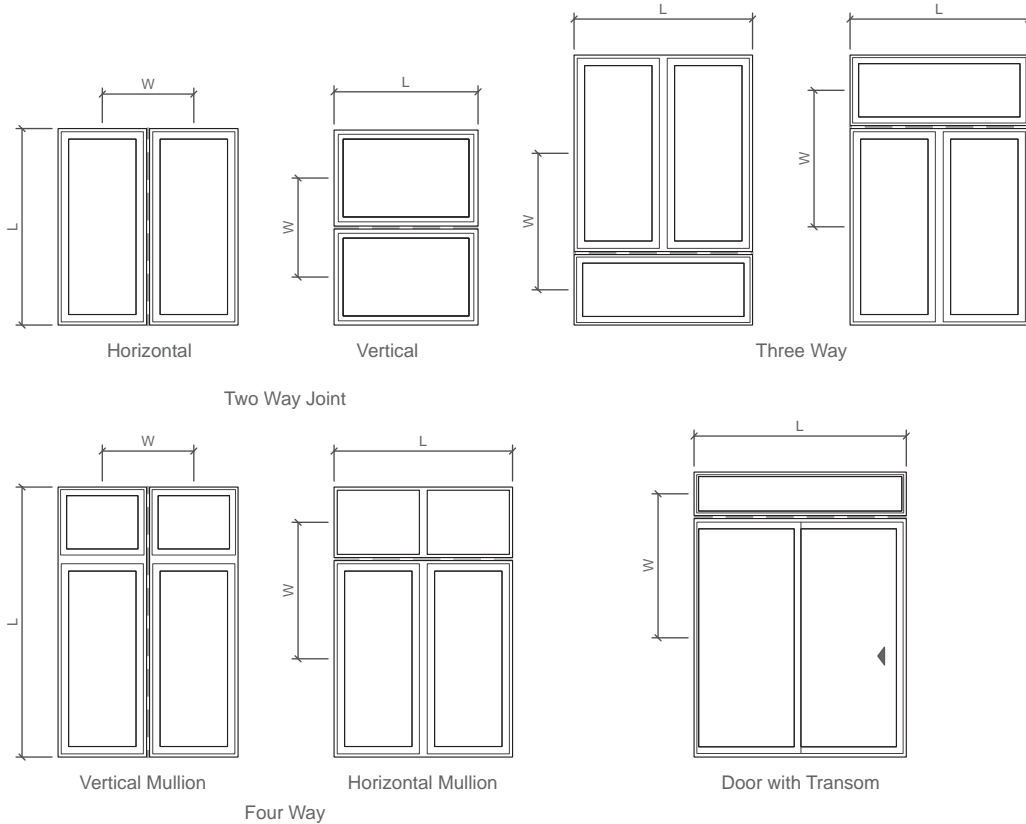

Determine reinforcing mullion for joint ② (horizontal mullion) = two way

A. Determine L = Mullion length (in)

B. Determine W = Windload width (in)

a. 1/2 the distance from the mullion to the member above = 30"

b. 1/2 the distance from the mullion to the member below = 12"

Joint ②

72"

42"

C. Determine minimum reinforcing mullion required

**Step 1** Enter the graph at the point of the mullion length (L).

Use 72"

**Step 2** Move to the loading width (W).

Use 48"

**Step 3** Move right to the column with the design pressure.

Use 25 psf

		MAXIMUM ALLOWABLE DESIGN PRESSURE (PSF)							
3	L (in)	W (in)	20	25	30	35	40	45	50
		72	24	A	A	A	B	B	B
	72	28	A	A	B	B	B	B	B
	72	30	A	B	B	B	B	B	B
	72	36	A	B	B	B	B	C	D
1	72	48	B	B	B	D	D	D	D
	72	54	B	B	C	D	D	D	F
2	72	60	B	B	D	D	D	F	F

See actual mullion load charts in this section for details.

Reinforcing mullion results:

Joint ② : Minimum reinforcing mullion B = 1/2" Structural Mullion. We will use E = 2- 2x4 wood studs for this example.

Continued on next page



# Impervia® Combinations

## Door and Window Typical Combinations - Sample Calculations

Determine reinforcing mullion for joint ③ = four-way joint

Joint ③

- A. Determine L = Mullion length (in)
- B. Determine W = Windload width (in)
  - a. 1/2 the distance from the mullion to the left member = 36"
  - b. 1/2 the distance from the mullion to the right member = 36"

84"  
72"

C. Determine minimum reinforcing mullion required

- Step 1** Enter the graph at the point of the mullion length (L). Use 96"
- Step 2** Move to the loading width (W). Use 72"
- Step 3** Move right to the column with the design pressure. Use 25 psf

Minimum reinforcing mullion:

I = 1" structural Mullion with 2 Reinforcements

We will use K = 2- 2x6 wood studs for this example.

		MAXIMUM ALLOWABLE DESIGN PRESSURE (PSF)						
L (in)	W (in)	20	25	30	35	40	45	50
		96	30	D	D	E	F	G
96	36	D	E	F	G	G	H	I
96	48	F	G	G	I	I	I	J
96	54	F	G	H	I	I	J	K
96	60	G	G	I	I	J	K	K
96	66	G	I	I	J	K	K	L
96	72	G	I	I	J	K	L	L

See actual mullion load charts in this section for details.  
(-) = Not Applicable

8. Determine actual rough opening size and window data:

Rough Opening Width:	EXAMPLE:
Rough Opening	144"
Jamb Clearance (1/4" x 2)	- 1/2"
Number of vertical mullions x (mullion reinforcement width + clearance when required) (3" x 1) + (1/4" x 2)	-3-1/2"
Total Window width	140"
Window width ÷ number of windows	70"

Rough Opening Height:	EXAMPLE:
Rough Opening	84"
Sill and head clearance (1/4" x 2)	- 1/2"
Number of horizontal mullions x (reinforcing mullion width + clearance when required) (3" x 1) + (1/4" x 2)	-3-1/2"
Total unit height (Use 4'8" frame height over 2'0" frame height units)	80"

Final Layout and Detail:

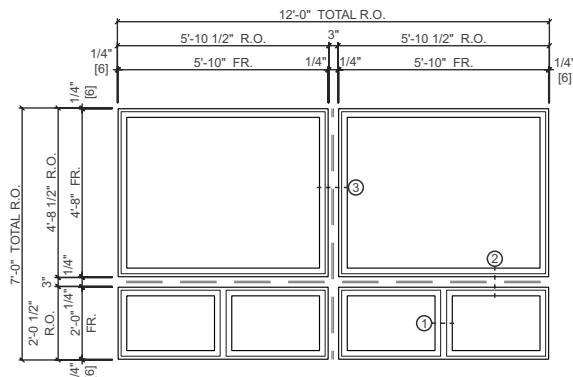

- ① Integral Mullion
- ② 2 - 2" x 4" Nominal Wood Reinforcing Mullion
- ③ 2 - 2" x 6" Nominal Wood Reinforcing Mullion



# Impervia® Combinations

## Two-Way Mullion of any Combination of Rectangle Windows

Maximum Allowable Design Pressure (psf)									
L (in)	W (in)	20	25	30	35	40	45	50	
42	60	A	A	A	A	A	A	A	
42	66	A	A	A	A	A	A	A	
42	72	A	A	A	A	A	A	A	
48	36	A	A	A	A	A	A	A	
48	48	A	A	A	A	A	A	A	
48	54	A	A	A	A	A	A	B	
48	60	A	A	A	A	A	B	B	
48	66	A	A	A	A	B	B	B	
48	72	A	A	A	B	B	B	B	
54	28	A	A	A	A	A	A	A	
54	30	A	A	A	A	A	A	A	
54	36	A	A	A	A	A	A	B	
54	48	A	A	A	A	B	B	B	
54	54	A	A	A	B	B	B	B	
54	60	A	A	B	B	B	B	B	
54	66	A	A	B	B	B	B	B	
54	72	A	B	B	B	B	B	B	
60	18	A	A	A	A	A	A	A	
60	24	A	A	A	A	A	A	A	
60	28	A	A	A	A	A	B	B	
60	30	A	A	A	A	A	B	B	
60	36	A	A	A	B	B	B	B	
60	48	A	A	B	B	B	B	B	
60	54	A	B	B	B	B	B	C	
60	60	A	B	B	B	B	C	D	
60	66	B	B	B	B	B	D	D	
60	72	B	B	B	B	D	D	D	
72	18	A	A	A	A	A	B	B	
72	24	A	A	A	B	B	B	B	
72	28	A	A	B	B	B	B	B	
72	30	A	B	B	B	B	B	B	
72	36	A	B	B	B	B	C	D	
72	48	B	B	B	D	D	D	D	
72	54	B	B	C	D	D	D	F	
72	60	B	B	D	D	D	F	F	
72	66	B	D	D	D	F	F	G	
72	72	B	D	D	E	F	G	G	
78	18	A	A	A	B	B	B	B	
78	24	A	B	B	B	B	B	B	
78	28	A	B	B	B	B	C	D	
78	30	B	B	B	B	B	D	D	
78	36	B	B	B	C	D	D	D	
78	48	B	B	D	D	D	F	F	
78	54	B	D	D	D	F	F	G	
78	60	B	D	D	F	F	G	G	
78	66	D	D	E	F	G	G	H	
78	72	D	D	F	G	G	H	I	
84	18	A	A	B	B	B	B	B	
84	24	B	B	B	B	B	D	D	
84	28	B	B	B	C	D	D	D	
84	30	B	B	B	D	D	D	D	
84	36	B	B	D	D	D	F	F	
84	48	B	D	D	F	F	G	G	
84	54	D	D	F	F	G	G	I	
84	60	D	D	F	G	G	I	I	
84	66	D	F	G	G	H	I	I	
84	72	D	F	G	G	I	I	J	

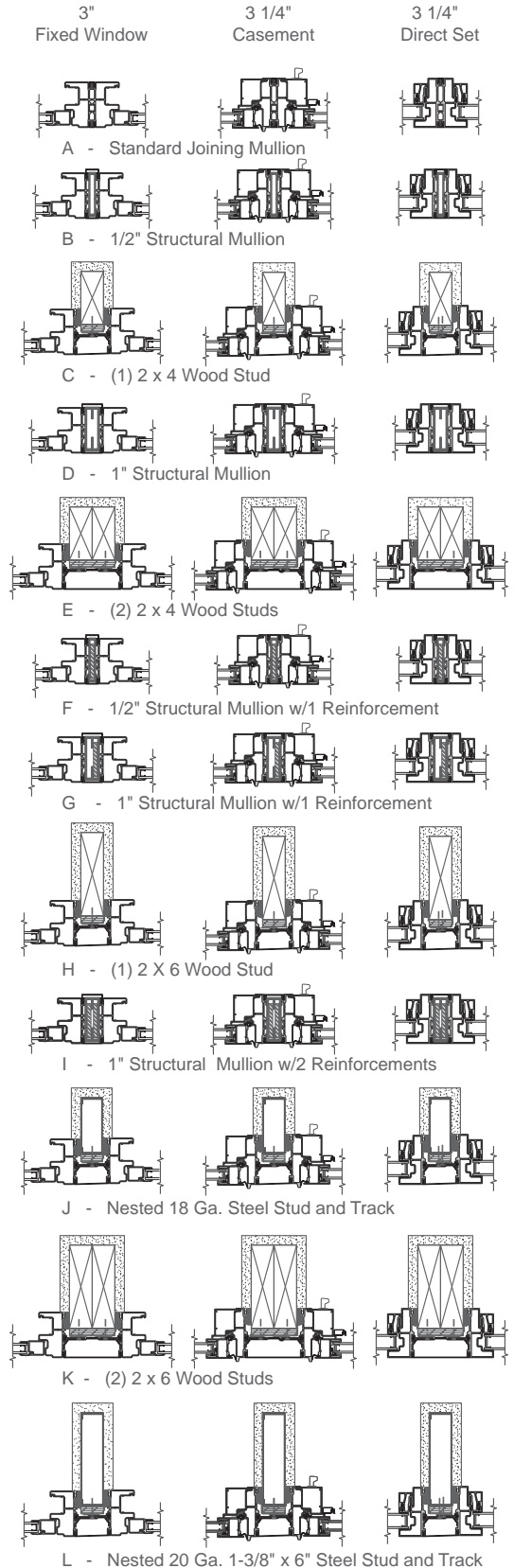
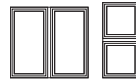

Continued on next page

- All reinforcing mullions must be properly secured at ends. Wall framing around window opening must be adequate to withstand wind loads transferred from window composite and reinforcing mullions.
- Do not use these accessories or mullions for structural vertical loading. Reinforcing mullions are for wind loading only.
- If mullion length or load factor exceed chart values, please contact your local Pella sales representative.
- Design charts are not valid for locations where impact forces from wind-borne debris must be considered.
- Chart shows mullion reinforcement requirements using engineered mullion strength values to meet  $L/175 \leq .75"$  deflection, per instructions on page 3.



# Impervia® Combinations

## Two-Way Mullion of any combination of Rectangle Windows

Maximum Allowable Design Pressure (psf)								
L (in)	W (in)	20	25	30	35	40	45	50
90	18	A	B	B	B	B	C	D
90	24	B	B	B	D	D	D	D
90	28	B	B	D	D	D	D	F
90	30	B	B	D	D	D	F	F
90	36	B	D	D	D	F	G	G
90	48	D	D	F	G	G	H	I
90	54	D	F	G	G	H	I	I
90	60	D	F	G	H	I	I	J
90	66	F	G	G	I	I	J	J
90	72	F	G	H	I	I	J	K
96	18	B	B	B	B	D	D	D
96	24	B	B	D	D	D	F	F
96	28	B	D	D	D	F	F	G
96	30	B	D	D	E	F	G	G
96	36	D	D	F	F	G	G	I
96	48	D	F	G	G	I	I	J
96	54	F	G	G	I	I	J	J
96	60	F	G	I	I	J	J	K
96	66	G	G	I	I	J	K	L
96	72	G	I	I	J	K	K	L
108	18	B	B	D	D	D	F	F
108	24	C	D	D	F	G	G	G
108	28	D	D	F	G	G	I	I
108	30	D	E	F	G	G	I	I
108	36	D	F	G	I	I	I	J
108	48	G	G	I	J	J	K	L
108	54	G	I	I	J	K	L	L
108	60	G	I	J	K	L	L	L
108	66	I	I	K	L	L	L	L
108	72	I	J	K	L	L	L	L

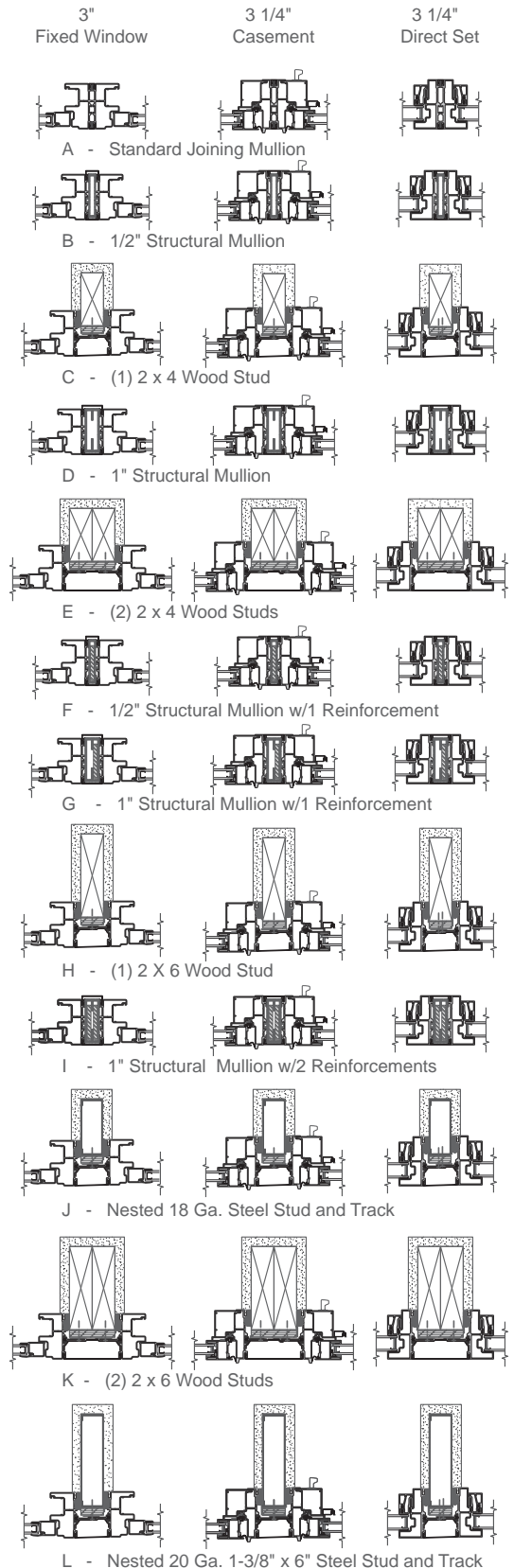
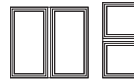

- All reinforcing mullions must be properly secured at ends. Wall framing around window opening must be adequate to withstand wind loads transferred from window composite and reinforcing mullions.
- Do not use these accessories or mullions for structural vertical loading. Reinforcing mullions are for wind loading only.
- If mullion length or load factor exceed chart values, please contact your local Pella sales representative.
- Design charts are not valid for locations where impact forces from wind-borne debris must be considered.
- Chart shows mullion reinforcement requirements using engineered mullion strength values to meet  $L/175 \leq .75"$  deflection, per instructions on page 3.



# Impervia® Combinations

## Three-Way Mullion of any combination of Rectangle Windows

Maximum Allowable Design Pressure (psf)									
L (in)	W (in)	20	25	30	35	40	45	50	
42	60	A	A	A	B	B	B	B	
42	66	A	A	B	B	B	B	B	
42	72	A	A	B	B	B	B	B	
48	36	A	A	A	B	B	B	B	
48	48	A	A	B	B	B	B	B	
48	54	A	B	B	B	B	B	B	
48	60	A	B	B	B	B	B	B	
48	66	B	B	B	B	B	B	B	
48	72	B	B	B	B	B	B	B	
54	28	A	A	A	B	B	B	B	
54	30	A	A	B	B	B	B	B	
54	36	A	B	B	B	B	B	B	
54	48	B	B	B	B	B	B	B	
54	54	B	B	B	B	B	B	B	
54	60	B	B	B	B	B	B	C	
54	66	B	B	B	B	B	C	D	
54	72	B	B	B	B	C	D	D	
60	18	A	A	A	B	B	B	B	
60	24	A	A	B	B	B	B	B	
60	28	A	B	B	B	B	B	B	
60	30	A	B	B	B	B	B	B	
60	36	B	B	B	B	B	B	B	
60	48	B	B	B	B	B	C	D	
60	54	B	B	B	B	C	D	D	
60	60	B	B	B	C	D	D	D	
60	66	B	B	B	D	D	D	D	
60	72	B	B	C	D	D	D	D	
72	18	A	B	B	B	B	B	B	
72	24	B	B	B	B	B	B	C	
72	28	B	B	B	B	B	C	D	
72	30	B	B	B	B	C	D	D	
72	36	B	B	B	C	D	D	D	
72	48	B	C	D	D	D	E	F	
72	54	B	D	D	D	E	F	F	
72	60	C	D	D	D	F	F	G	
72	66	D	D	D	F	F	G	G	
72	72	D	D	E	F	G	G	G	
78	18	B	B	B	B	B	B	B	
78	24	B	B	B	B	C	D	D	
78	28	B	B	B	C	D	D	D	
78	30	B	B	B	D	D	D	D	
78	36	B	B	D	D	D	D	F	
78	48	C	D	D	E	F	F	G	
78	54	D	D	D	F	F	G	G	
78	60	D	D	F	F	G	G	H	
78	66	D	D	F	G	G	H	I	
78	72	D	F	F	G	G	I	I	

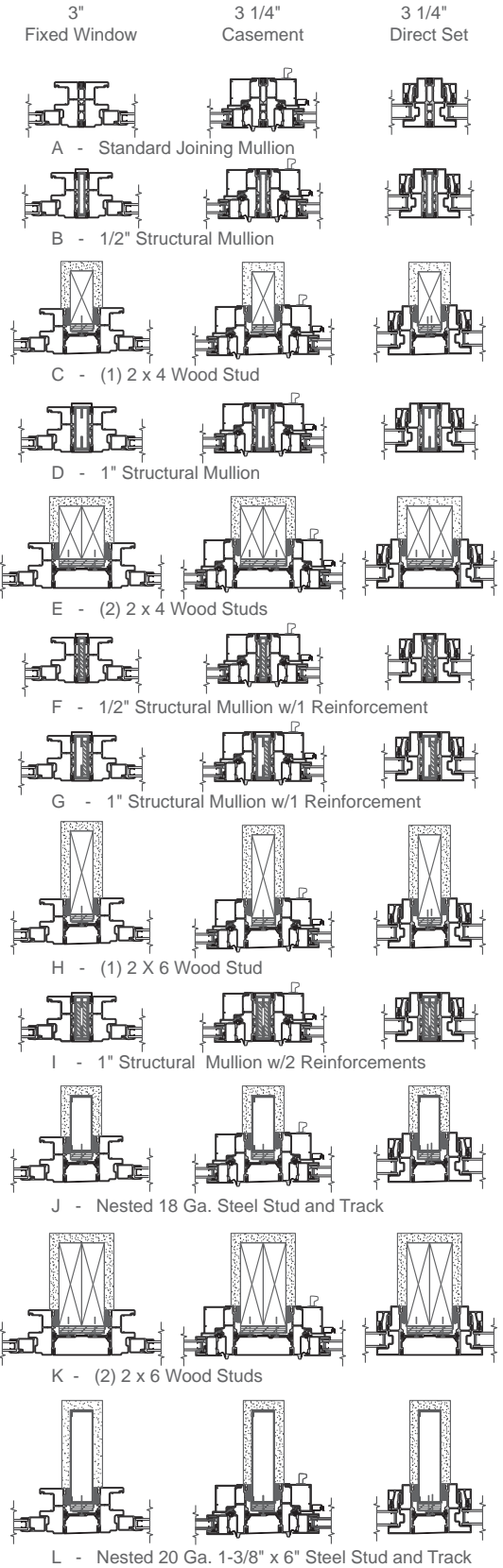

Continued on next page

- All reinforcing mullions must be properly secured at ends. Wall framing around window opening must be adequate to withstand wind loads transferred from window composite and reinforcing mullions.
- Do not use these accessories or mullions for structural vertical loading. Reinforcing mullions are for wind loading only.
- If mullion length or load factor exceed chart values, please contact your local Pella sales representative.
- Design charts are not valid for locations where impact forces from wind-borne debris must be considered.
- Chart shows mullion reinforcement requirements using engineered mullion strength values to meet  $L/175 \leq .75"$  deflection, per instructions on page 3.



# Impervia® Combinations

## Three-Way Mullion of any combination Rectangle Windows

Maximum Allowable Design Pressure (psf)									
L (in)	W (in)	20	25	30	35	40	45	50	
84	18	B	B	B	B	B	D	D	
84	24	B	B	B	D	D	D	D	
84	28	B	B	D	D	D	D	F	
84	30	B	C	D	D	D	E	F	
84	36	B	D	D	D	F	F	G	
84	48	D	D	F	F	G	G	H	
84	54	D	E	F	G	G	H	I	
84	60	D	F	G	G	H	I	I	
84	66	D	F	G	G	I	I	I	
84	72	F	G	G	I	I	I	J	
90	18	B	B	B	C	D	D	D	
90	24	B	C	D	D	D	E	F	
90	28	B	D	D	D	F	F	F	
90	30	C	D	D	D	F	F	G	
90	36	D	D	E	F	G	G	G	
90	48	D	F	G	G	H	I	I	
90	54	E	F	G	G	I	I	I	
90	60	F	G	G	I	I	I	J	
90	66	F	G	H	I	I	J	K	
90	72	G	G	I	I	J	K	K	
96	18	B	B	D	D	D	D	E	
96	24	B	D	D	D	F	F	G	
96	28	D	D	D	F	F	G	G	
96	30	D	D	E	F	G	G	G	
96	36	D	E	F	G	G	H	I	
96	48	F	G	G	I	I	I	J	
96	54	F	G	H	I	I	J	K	
96	60	G	G	I	I	J	K	K	
96	66	G	I	I	J	K	K	L	
96	72	G	I	I	J	K	L	L	
108	18	C	D	D	E	F	F	G	
108	24	D	D	F	G	G	G	I	
108	28	D	F	G	G	H	I	I	
108	30	D	F	G	G	I	I	I	
108	36	F	G	G	I	I	J	J	
108	48	G	I	I	J	K	K	L	
108	54	G	I	J	K	K	L	L	
108	60	I	I	J	K	L	L	L	
108	66	I	J	K	L	L	L	L	
108	72	I	J	K	L	L	L	L	

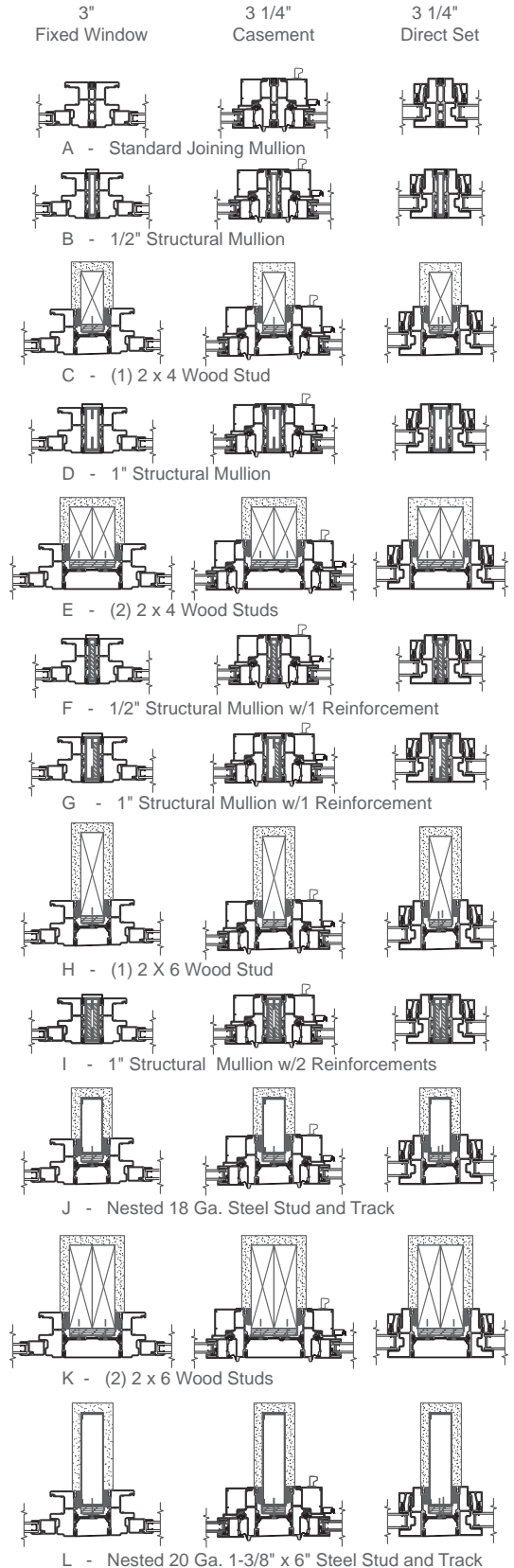

- All reinforcing mullions must be properly secured at ends. Wall framing around window opening must be adequate to withstand wind loads transferred from window composite and reinforcing mullions.
- Do not use these accessories or mullions for structural vertical loading. Reinforcing mullions are for wind loading only.
- If mullion length or load factor exceed chart values, please contact your local Pella sales representative.
- Design charts are not valid for locations where impact forces from wind-borne debris must be considered.
- Chart shows mullion reinforcement requirements using engineered mullion strength values to meet  $L/175 \leq .75"$  deflection, per instructions on page 3.



# Impervia® Combinations

## Four-Way Mullion any combination or Rectangle Windows

Maximum Allowable Design Pressure (psf)									
L (in)	W (in)	20	25	30	35	40	45	50	
42	60	B	B	B	B	B	B	B	
42	66	B	B	B	B	B	B	D	
42	72	B	B	B	B	B	D	D	
48	36	B	B	B	B	B	B	B	
48	48	B	B	B	B	B	B	B	
48	54	B	B	B	B	B	D	D	
48	60	B	B	B	B	B	D	D	
48	66	B	B	B	B	D	D	D	
48	72	B	B	B	D	D	D	D	
54	28	B	B	B	B	B	B	B	
54	30	B	B	B	B	B	B	B	
54	36	B	B	B	B	B	B	B	
54	48	B	B	B	B	D	D	D	
54	54	B	B	B	B	D	D	D	
54	60	B	B	B	D	D	D	D	
54	66	B	B	D	D	D	D	D	
54	72	B	B	D	D	D	D	D	
60	18	B	B	B	B	B	B	B	
60	24	B	B	B	B	B	B	B	
60	28	B	B	B	B	B	B	C	
60	30	B	B	B	B	B	B	C	
60	36	B	B	B	B	C	D	D	
60	48	B	B	C	D	D	D	D	
60	54	B	B	D	D	D	D	F	
60	60	B	C	D	D	D	D	D	
60	66	B	D	D	D	D	D	F	
60	72	C	D	D	D	D	F	F	
72	18	B	B	B	B	B	C	C	
72	24	B	B	B	C	D	D	D	
72	28	B	B	C	D	D	D	D	
72	30	B	B	C	D	D	D	D	
72	36	B	C	D	D	D	D	E	
72	48	D	D	D	D	F	F	F	
72	54	D	D	D	F	F	G	G	
72	60	D	D	E	F	F	G	G	
72	66	D	D	F	F	G	G	G	
72	72	D	E	F	G	G	G	I	
78	18	B	B	B	B	D	D	D	
78	24	B	B	D	D	D	D	D	
78	28	B	C	D	D	D	D	E	
78	30	B	D	D	D	D	D	F	
78	36	D	D	D	D	F	F	F	
78	48	D	D	F	F	G	G	G	
78	54	D	D	F	F	G	G	H	
78	60	D	F	F	G	G	H	I	
78	66	D	F	G	G	H	I	I	
78	72	F	F	G	G	I	I	I	
84	18	B	B	C	D	D	D	D	
84	24	B	D	D	D	D	D	F	
84	28	C	D	D	D	E	F	F	
84	30	D	D	D	D	F	F	F	
84	36	D	D	D	F	F	G	G	
84	48	D	F	F	G	G	H	I	
84	54	D	F	G	G	H	I	I	
84	60	F	F	G	G	I	I	I	
84	66	F	G	G	I	I	I	J	
84	72	F	G	H	I	I	J	J	

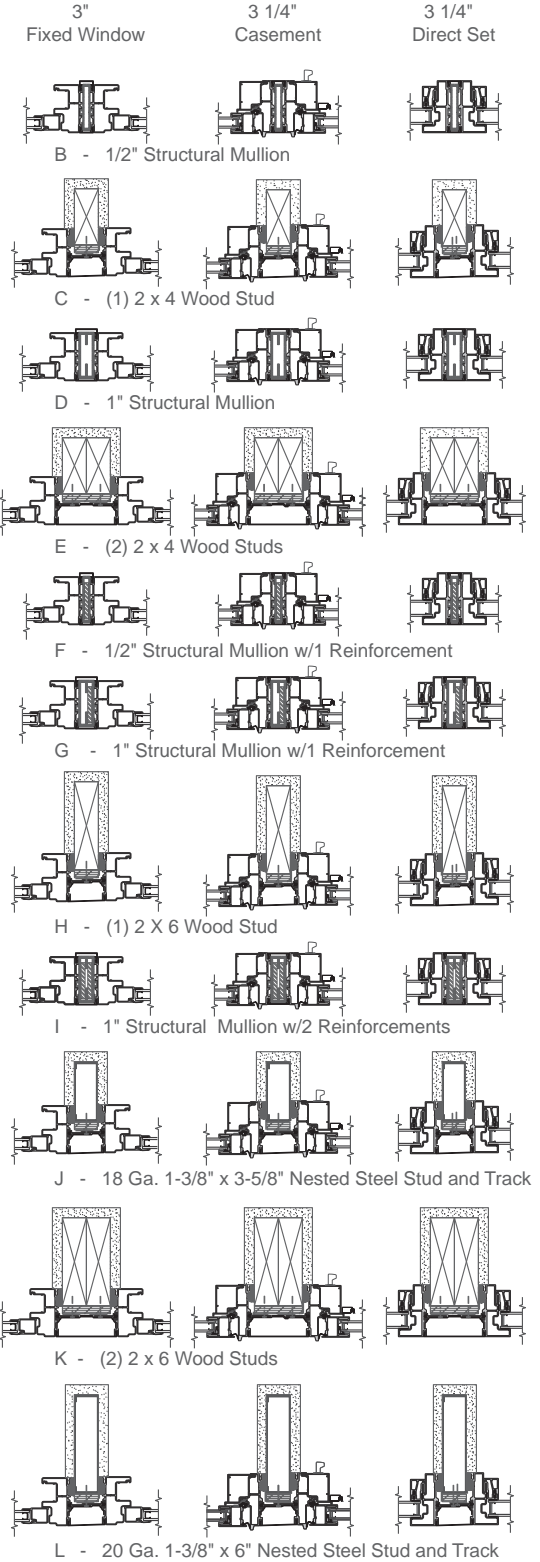

Continued on next page

(-) = Not Applicable

- All reinforcing mullions must be properly secured at ends. Wall framing around window opening must be adequate to withstand wind loads transferred from window composite and reinforcing mullions.
- Do not use these accessories or mullions for structural vertical loading. Reinforcing mullions are for wind loading only.
- If mullion length or load factor exceed chart values, please contact your local Pella sales representative.
- Design charts are not valid for locations where impact forces from wind-borne debris must be considered.
- Chart shows mullion reinforcement requirements using engineered mullion strength values to meet  $L/175 \leq .75"$  deflection, per instructions on page 3.



# Impervia® Combinations

## Four-Way Mullion any combination Rectangle Windows

Maximum Allowable Design Pressure (psf)								
L (in)	W (in)	20	25	30	35	40	45	50
90	18	B	C	D	D	D	D	E
90	24	D	D	D	D	F	F	F
90	28	D	D	D	F	F	G	G
90	30	D	D	E	F	F	G	G
90	36	D	E	F	G	G	G	H
90	48	F	F	G	G	I	I	I
90	54	F	G	G	I	I	I	J
90	60	F	G	H	I	I	J	K
90	66	G	G	I	I	J	J	K
90	72	G	H	I	I	J	K	K
96	18	C	D	D	D	D	F	F
96	24	D	D	D	F	F	G	G
96	28	D	D	F	F	G	G	G
96	30	D	E	F	G	G	G	I
96	36	D	F	G	G	H	I	I
96	48	F	G	H	I	I	J	J
96	54	G	G	I	I	J	J	K
96	60	G	I	I	J	K	K	L
96	66	G	I	I	J	K	K	L
96	72	H	I	J	K	K	L	—
108	18	D	D	F	F	G	G	G
108	24	D	F	G	G	G	I	I
108	28	F	F	G	G	I	I	I
108	30	F	G	G	I	I	I	J
108	36	G	G	I	I	I	J	K
108	48	G	I	I	J	K	L	L
108	54	I	I	J	K	L	L	L
108	60	I	J	K	L	L	L	—
108	66	I	J	K	L	L	—	—
108	72	I	K	L	L	—	—	—

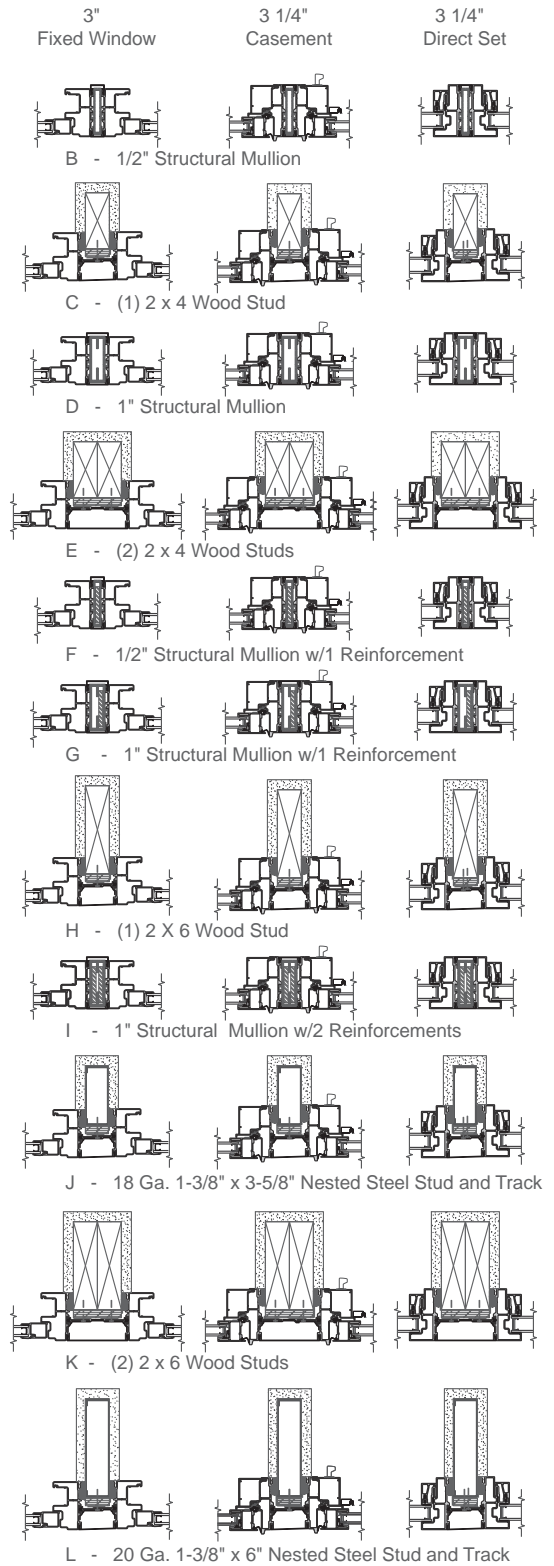

(—) = Not Applicable

- All reinforcing mullions must be properly secured at ends. Wall framing around window opening must be adequate to withstand wind loads transferred from window composite and reinforcing mullions.
- Do not use these accessories or mullions for structural vertical loading. Reinforcing mullions are for wind loading only.
- If mullion length or load factor exceed chart values, please contact your local Pella sales representative.
- Design charts are not valid for locations where impact forces from wind-borne debris must be considered.
- Chart shows mullion reinforcement requirements using engineered mullion strength values to meet  $L/175 \leq .75"$  deflection, per instructions on page 3.



# Impervia® Combinations

## Two-Way Mullion of Rectangle Window to Special Shape

Maximum Allowable Design Pressure (psf)									
L (in)	W (in)	20	25	30	35	40	45	50	
42	60	A	A	A	B	B	B	B	
42	66	A	A	A	B	B	B	B	
42	72	A	A	B	B	B	B	B	
48	36	A	A	A	A	B	B	B	
48	48	A	A	B	B	B	B	B	
48	54	A	B	B	B	B	B	B	
48	60	A	B	B	B	B	B	B	
48	66	A	B	B	B	B	B	B	
48	72	B	B	B	B	B	B	B	
54	28	A	A	A	B	B	B	B	
54	30	A	A	A	B	B	B	B	
54	36	A	A	B	B	B	B	B	
54	48	B	B	B	B	B	B	B	
54	54	B	B	B	B	B	B	B	
54	60	B	B	B	B	B	B	C	
54	66	B	B	B	B	B	C	D	
54	72	B	B	B	B	C	D	D	
60	18	A	A	A	A	B	B	B	
60	24	A	A	B	B	B	B	B	
60	28	A	B	B	B	B	B	B	
60	30	A	B	B	B	B	B	B	
60	36	B	B	B	B	B	B	B	
60	48	B	B	B	B	B	C	D	
60	54	B	B	B	B	C	D	D	
60	60	B	B	B	C	D	D	D	
60	66	B	B	B	D	D	D	D	
60	72	B	B	C	D	D	D	D	
72	18	A	B	B	B	B	B	B	
72	24	B	B	B	B	B	B	B	
72	28	B	B	B	B	B	C	D	
72	30	B	B	B	B	B	D	D	
72	36	B	B	B	C	D	D	D	
72	48	B	B	D	D	D	E	F	
72	54	B	D	D	D	E	F	F	
72	60	B	D	D	D	F	F	G	
72	66	D	D	D	F	F	G	G	
72	72	D	D	E	F	G	G	G	
78	18	B	B	B	B	B	C	D	
78	24	B	B	B	B	C	D	D	
78	28	B	B	B	C	D	D	D	
78	30	B	B	B	D	D	D	D	
78	36	B	B	D	D	D	D	F	
78	48	C	D	D	D	F	F	G	
78	54	D	D	D	F	F	G	G	
78	60	D	D	F	F	G	G	H	
78	66	D	D	F	G	G	H	I	
78	72	D	F	F	G	G	I	I	
84	18	B	B	B	B	B	C	D	
84	24	B	B	B	D	D	D	D	
84	28	B	B	D	D	D	D	F	
84	30	B	B	D	D	D	E	F	
84	36	B	D	D	D	F	F	G	
84	48	D	D	F	F	G	G	H	
84	54	D	E	F	G	G	H	I	
84	60	D	F	G	G	H	I	I	
84	66	D	F	G	G	I	I	I	
84	72	F	G	G	I	I	I	J	

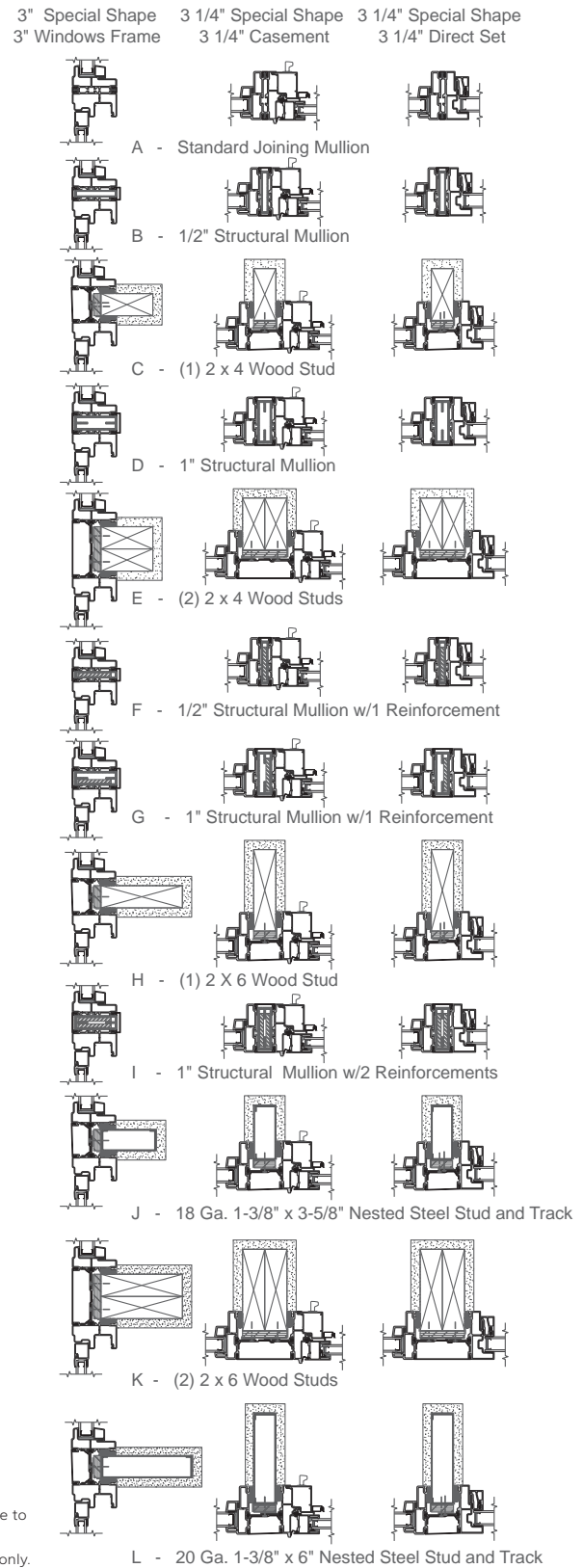
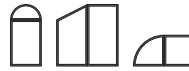

Continued on next page

- All reinforcing mullions must be properly secured at ends. Wall framing around window opening must be adequate to withstand wind loads transferred from window composite and reinforcing mullions.
- Do not use these accessories or mullions for structural vertical loading. Reinforcing mullions are for wind loading only.
- If mullion length or load factor exceed chart values, please contact your local Pella sales representative.
- Design charts are not valid for locations where impact forces from wind-borne debris must be considered.
- Chart shows mullion reinforcement requirements using engineered mullion strength values to meet  $L/175 \leq .75"$  deflection, per instructions on page 3.



# Impervia® Combinations

## Two-Way Mullion Rectangle Window to Special Shape

Maximum Allowable Design Pressure (psf)								
L (in)	W (in)	20	25	30	35	40	45	50
90	18	B	B	B	C	D	D	D
90	24	B	B	D	D	D	D	F
90	28	B	D	D	D	E	F	F
90	30	B	D	D	D	F	F	G
90	36	D	D	D	F	G	G	G
90	48	D	F	G	G	H	I	I
90	54	D	F	G	G	I	I	I
90	60	F	G	G	I	I	I	J
90	66	F	G	H	I	I	J	K
90	72	G	G	I	I	J	K	K
96	18	B	B	C	D	D	D	D
96	24	B	D	D	D	F	F	G
96	28	D	D	D	F	F	G	G
96	30	D	D	D	F	G	G	G
96	36	D	D	F	G	G	H	I
96	48	F	G	G	I	I	I	J
96	54	F	G	H	I	I	J	K
96	60	G	G	I	I	J	K	K
96	66	G	H	I	J	K	K	L
96	72	G	I	I	J	K	L	L
108	18	C	D	D	D	F	F	G
108	24	D	D	F	G	G	G	I
108	28	D	F	G	G	H	I	I
108	30	D	F	G	G	I	I	I
108	36	F	G	G	I	I	J	J
108	48	G	I	I	J	K	K	L
108	54	G	I	J	K	K	L	L
108	60	I	I	J	K	L	L	L
108	66	I	J	K	L	L	L	L
108	72	I	J	K	L	L	L	L

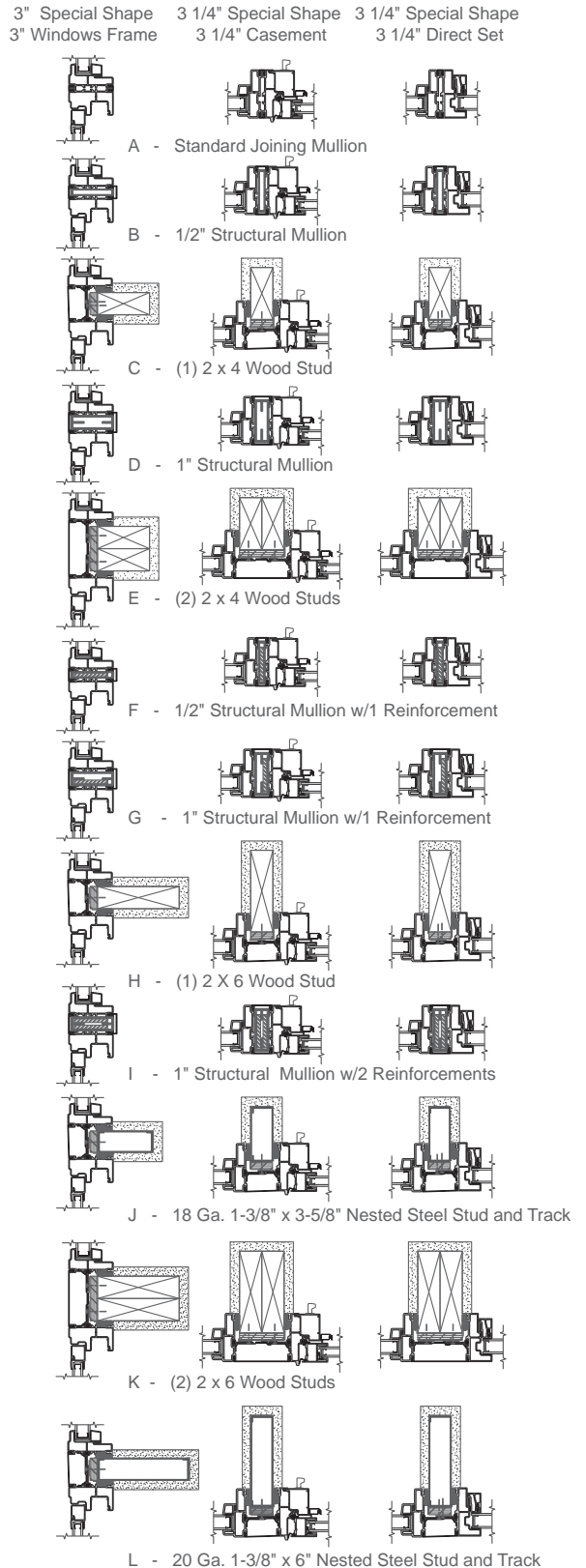
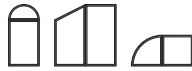

- All reinforcing mullions must be properly secured at ends. Wall framing around window opening must be adequate to withstand wind loads transferred from window composite and reinforcing mullions.
- Do not use these accessories or mullions for structural vertical loading. Reinforcing mullions are for wind loading only.
- If mullion length or load factor exceed chart values, please contact your local Pella sales representative.
- Design charts are not valid for locations where impact forces from wind-borne debris must be considered.
- Chart shows mullion reinforcement requirements using engineered mullion strength values to meet  $L/175 \leq .75"$  deflection, per instructions on page 3.



Three-Way Mullion of 2 Rectangle Windows to a Special Shape Window

Maximum Allowable Design Pressure (psf)								
L (in)	W (in)	20	25	30	35	40	45	50
42	60	B	B	B	B	B	B	B
42	66	B	B	B	B	B	B	B
42	72	B	B	B	B	B	B	B
48	36	B	B	B	B	B	B	B
48	48	B	B	B	B	B	B	B
48	54	B	B	B	B	B	B	B
48	60	B	B	B	B	B	B	C
48	66	B	B	B	B	B	C	D
48	72	B	B	B	B	C	D	D
54	28	B	B	B	B	B	B	B
54	30	B	B	B	B	B	B	B
54	36	B	B	B	B	B	B	B
54	48	B	B	B	B	B	C	D
54	54	B	B	B	B	C	D	D
54	60	B	B	B	C	D	D	D
54	66	B	B	B	D	D	D	D
54	72	B	B	C	D	D	D	D
60	18	B	B	B	B	B	B	B
60	24	B	B	B	B	B	B	B
60	28	B	B	B	B	B	B	B
60	30	B	B	B	B	B	B	C
60	36	B	B	B	B	B	C	D
60	48	B	B	B	D	D	D	D
60	54	B	B	C	D	D	D	D
60	60	B	C	D	D	D	D	D
60	66	B	D	D	D	D	D	F
60	72	B	D	D	D	D	F	F
72	18	B	B	B	B	B	B	C
72	24	B	B	B	B	D	D	D
72	28	B	B	B	D	D	D	D
72	30	B	B	C	D	D	D	D
72	36	B	C	D	D	D	D	E
72	48	D	D	D	D	F	F	F
72	54	D	D	D	F	F	F	G
72	60	D	D	E	F	F	G	G
72	66	D	D	F	F	G	G	G
72	72	D	E	F	G	G	G	I
78	18	B	B	B	B	C	D	D
78	24	B	B	C	D	D	D	D
78	28	B	C	D	D	D	D	E
78	30	B	D	D	D	D	D	F
78	36	C	D	D	D	E	F	F
78	48	D	D	E	F	F	G	G
78	54	D	D	F	F	G	G	H
78	60	D	F	F	G	G	H	I
78	66	D	F	G	G	G	I	I
78	72	E	F	G	G	I	I	I
84	18	B	B	C	D	D	D	D
84	24	B	D	D	D	D	D	F
84	28	C	D	D	D	D	F	F
84	30	D	D	D	D	F	F	F
84	36	D	D	D	F	F	G	G
84	48	D	F	F	G	G	H	I
84	54	D	F	G	G	H	I	I
84	60	F	F	G	G	I	I	I
84	66	F	G	G	I	I	I	J
84	72	F	G	H	I	I	J	J

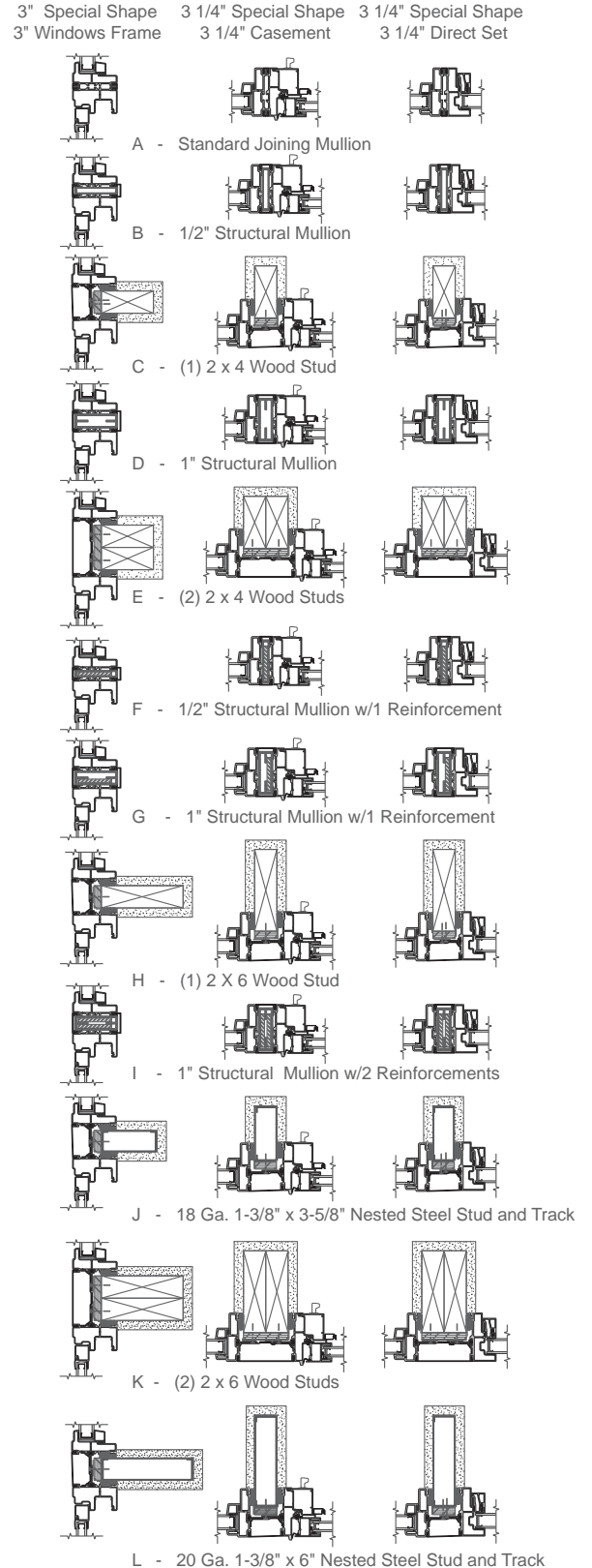

Continued on next page

(-) = Not Applicable

- All reinforcing mullions must be properly secured at ends. Wall framing around window opening must be adequate to withstand wind loads transferred from window composite and reinforcing mullions.
- Do not use these accessories or mullions for structural vertical loading. Reinforcing mullions are for wind loading only.
- If mullion length or load factor exceed chart values, please contact your local Pella sales representative.
- Design charts are not valid for locations where impact forces from wind-borne debris must be considered.
- Chart shows mullion reinforcement requirements using engineered mullion strength values to meet  $L/175 \leq .75"$  deflection, per instructions on page 3.



# Impervia® Combinations

## Three-Way Mullion of 2 Rectangle Windows to a Special Shape Window

Maximum Allowable Design Pressure (psf)								
L (in)	W (in)	20	25	30	35	40	45	50
90	18	B	C	D	D	D	D	D
90	24	C	D	D	D	F	F	F
90	28	D	D	D	F	F	G	G
90	30	D	D	D	F	F	G	G
90	36	D	D	F	G	G	G	H
90	48	F	F	G	G	I	I	I
90	54	F	G	G	I	I	I	J
90	60	F	G	H	I	I	J	J
90	66	G	G	I	I	J	J	K
90	72	G	H	I	I	J	K	K
96	18	C	D	D	D	D	F	F
96	24	D	D	D	F	F	G	G
96	28	D	D	F	F	G	G	G
96	30	D	D	F	G	G	G	H
96	36	D	F	G	G	H	I	I
96	48	F	G	H	I	I	J	J
96	54	G	G	I	I	J	J	K
96	60	G	H	I	I	J	K	L
96	66	G	I	I	J	K	K	L
96	72	H	I	J	K	K	L	L
108	18	D	D	E	F	F	G	G
108	24	D	F	F	G	G	I	I
108	28	F	F	G	G	I	I	I
108	30	F	G	G	H	I	I	J
108	36	F	G	I	I	I	J	K
108	48	G	I	I	J	K	L	L
108	54	I	I	J	K	L	L	L
108	60	I	J	K	L	L	L	L
108	66	I	J	K	L	L	L	L
108	72	I	K	L	L	L	L	L

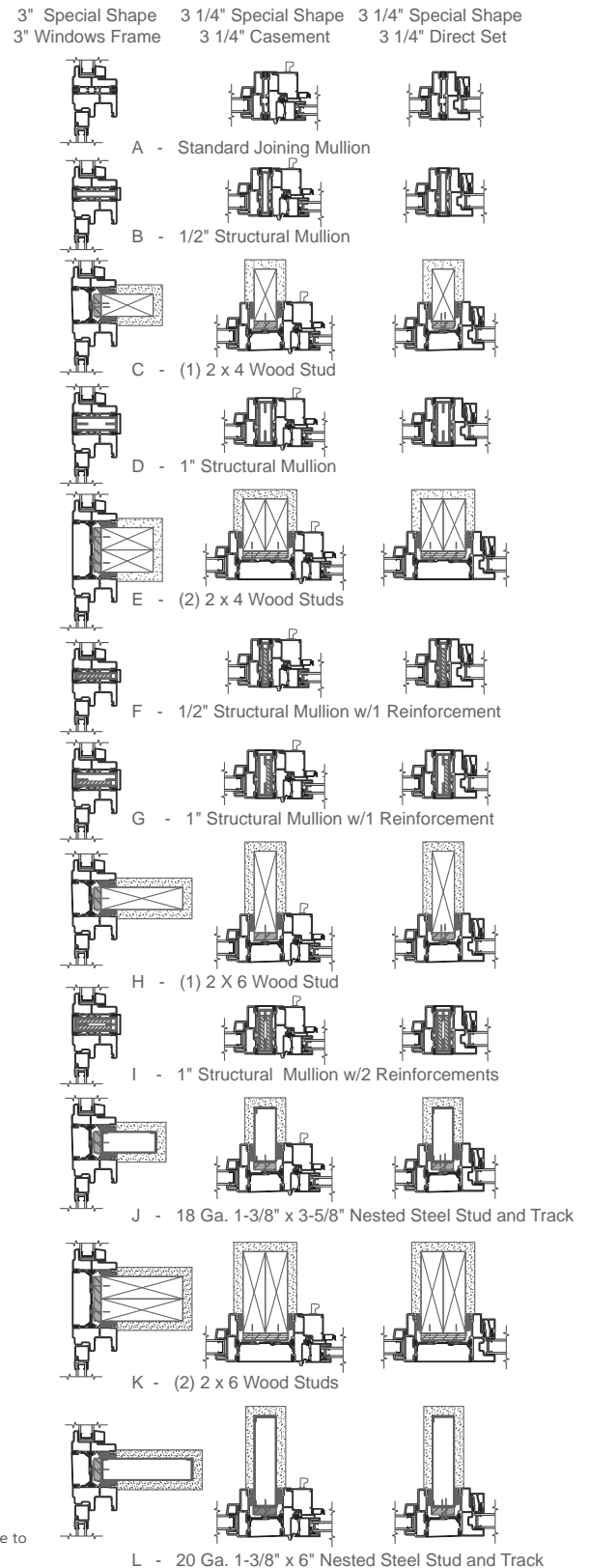

(-) = Not Applicable

- All reinforcing mullions must be properly secured at ends. Wall framing around window opening must be adequate to withstand wind loads transferred from window composite and reinforcing mullions.
- Do not use these accessories or mullions for structural vertical loading. Reinforcing mullions are for wind loading only.
- If mullion length or load factor exceed chart values, please contact your local Pella sales representative.
- Design charts are not valid for locations where impact forces from wind-borne debris must be considered.
- Chart shows mullion reinforcement requirements using engineered mullion strength values to meet  $L/175 \leq .75"$  deflection, per instructions on page 3.



# Impervia® Combinations

## Two-Way Mullion, Vertical Door to Door

Maximum Allowable Design Pressure (psf)								
L (in)	W (in)	20	25	30	35	40	45	50
71.5	71.250	A	A	A	A	A	A	A
71.5	79.875	A	A	A	A	A	A	B
71.5	83.250	A	A	A	A	A	A	B
71.5	95.250	A	A	A	A	A	B	B
79.5	50.625	A	A	A	A	A	A	A
79.5	59.250	A	A	A	A	A	A	B
79.5	71.250	A	A	A	A	A	B	C
79.5	79.875	A	A	A	A	B	C	C
79.5	83.250	A	A	A	B	B	C	C
79.5	95.250	A	A	B	B	C	D	D
81.5	50.625	A	A	A	A	A	A	A
81.5	59.250	A	A	A	A	A	B	B
81.5	71.250	A	A	A	A	B	B	C
81.5	79.875	A	A	A	B	B	C	D
81.5	83.250	A	A	A	B	C	C	D
81.5	95.250	A	A	B	C	C	D	D
95.5	32.625	A	A	A	A	A	A	A
95.5	38.625	A	A	A	A	A	B	B
95.5	44.625	A	A	A	A	B	B	C
95.5	50.625	A	A	A	B	B	C	D
95.5	59.250	A	A	B	C	C	D	D
95.5	71.250	A	B	C	D	D	F	F
95.5	79.875	A	B	C	D	F	F	G
95.5	83.250	B	C	D	D	F	F	H
95.5	95.250	B	C	D	F	F	H	J
107.5	27.000	A	A	A	A	A	B	B
107.5	32.625	A	A	A	A	B	C	C
107.5	38.625	A	A	B	B	C	D	D
107.5	44.625	A	A	B	C	D	D	E
107.5	50.625	A	B	C	D	D	F	F
107.5	59.250	B	C	D	D	F	F	H
107.5	71.250	B	D	D	F	G	I	J
107.5	79.875	C	D	F	G	I	J	K
107.5	83.250	C	D	F	H	J	K	L
107.5	95.250	D	F	G	J	K	L	L
119.5	27.000	A	A	A	B	C	C	D
119.5	32.625	A	A	B	C	D	D	F
119.5	38.625	A	B	C	D	D	F	F
119.5	44.625	B	C	D	D	F	G	H
119.5	50.625	B	D	D	F	G	H	J
119.5	59.250	C	D	F	G	I	K	K
119.5	71.250	D	F	H	J	K	L	L
119.5	79.875	D	G	J	K	L	L	L
119.5	83.250	F	G	J	K	L	L	—
119.5	95.250	F	I	K	L	L	—	—

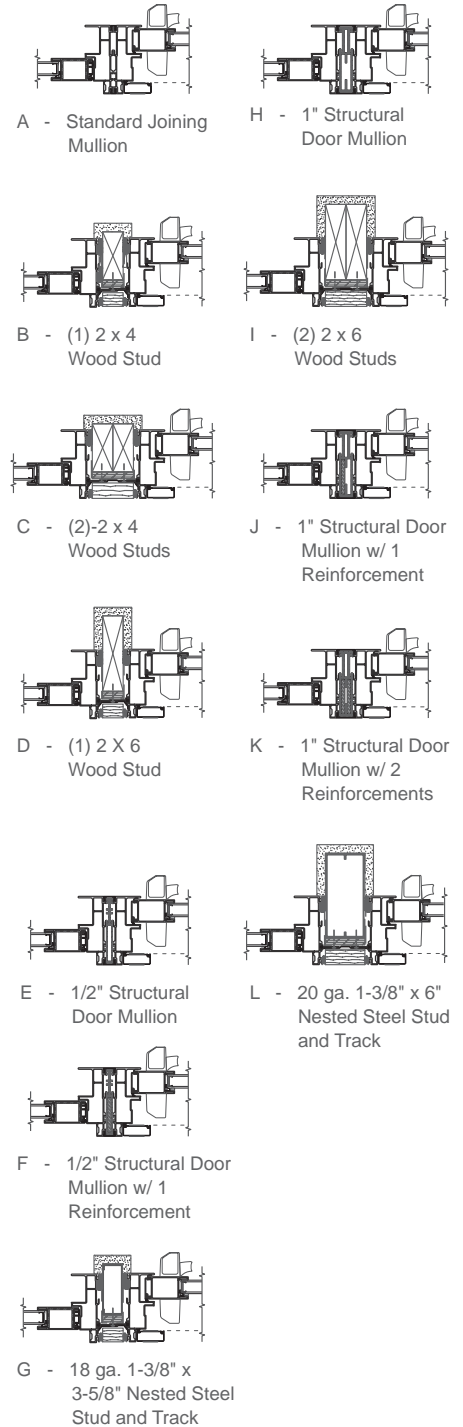
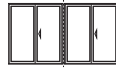

- All reinforcing mullions must be properly secured at ends. Wall framing around window opening must be adequate to withstand wind loads transferred from window composite and reinforcing mullions.
- Do not use these accessories or mullions for structural vertical loading. Reinforcing mullions are for wind loading only.
- If mullion length or load factor exceed chart values, please contact your local Pella sales representative.
- Design charts are not valid for locations where impact forces from wind-borne debris must be considered.
- Chart shows mullion reinforcement requirements using engineered mullion strength values to meet  $L/175 \leq .75"$  deflection, per instructions on page 3.



# Impervia® Combinations

## Two-Way Mullion, Horizontal Door to Rectangle Transom

Maximum Allowable Design Pressure (psf)								
L (in)	W (in)	20	25	30	35	40	45	50
59.25	83.75	A	A	A	A	A	A	A
59.25	89.75	A	A	A	A	A	A	B
59.25	95.75	A	A	A	A	A	A	B
59.25	101.75	A	A	A	A	A	B	B
59.25	107.75	A	A	A	A	A	B	B
71.25	46.75	A	A	A	A	A	A	A
71.25	53.75	A	A	A	A	A	A	B
71.25	59.75	A	A	A	A	A	B	B
71.25	65.75	A	A	A	A	B	B	B
71.25	71.75	A	A	A	A	B	B	C
71.25	77.75	A	A	A	B	B	C	C
71.25	83.75	A	A	A	B	B	C	C
71.25	89.75	A	A	B	B	C	C	D
71.25	95.75	A	A	B	B	C	C	D
71.25	101.75	A	B	B	C	C	D	D
71.25	107.75	A	B	B	C	C	D	D
79.875	46.75	A	A	A	A	B	B	B
79.875	53.75	A	A	A	B	B	B	C
79.875	59.75	A	A	A	B	B	C	C
79.875	65.75	A	A	B	B	C	C	D
79.875	71.75	A	A	B	C	C	D	D
79.875	77.75	A	B	B	C	C	D	D
79.875	83.75	A	B	C	C	D	D	D
79.875	89.75	A	B	C	D	D	D	F
79.875	95.75	B	B	C	D	D	D	F
79.875	101.75	B	C	C	D	D	F	F
79.875	107.75	B	C	D	D	D	F	F
83.25	46.75	A	A	A	B	B	B	C
83.25	53.75	A	A	B	B	B	C	C
83.25	59.75	A	A	B	B	C	C	D
83.25	65.75	A	B	B	C	C	D	D
83.25	71.75	A	B	B	C	D	D	D
83.25	77.75	A	B	C	C	D	D	E
83.25	83.75	B	B	C	D	D	D	F
83.25	89.75	B	C	C	D	D	F	F
83.25	95.75	B	C	D	D	D	F	F
83.25	101.75	B	C	D	D	F	F	G
83.25	107.75	B	C	D	D	F	F	H



3 1/4" Direct Set  
5" Door



A - Standard Joining Mullion

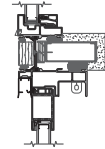

G - 18 ga. 1-3/8" x 3-5/8" Nested Steel Stud and Track

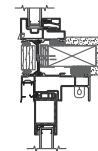

B - (1) 2 x 4 Wood Stud



H - 1" Structural Door Mullion

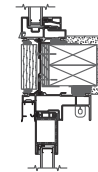

C - (2)-2 x 4 Wood Studs

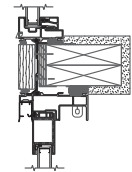

I - (2) 2 x 6 Wood Studs

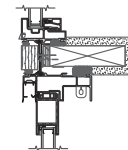

D - (1) 2 X 6 Wood Stud



J - 1" Structural Door Mullion w/ 1 Reinforcement



E - 1/2" Structural Door Mullion



K - 1" Structural Door Mullion w/ 2 Reinforcements



F - 1/2" Structural Door Mullion w/ 1 Reinforcement

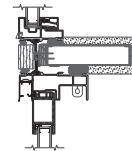

L - 20 ga. 1-3/8" x 6" Nested Steel Stud and Track

Continued on next page

- All reinforcing mullions must be properly secured at ends. Wall framing around window opening must be adequate to withstand wind loads transferred from window composite and reinforcing mullions.
- Do not use these accessories or mullions for structural vertical loading. Reinforcing mullions are for wind loading only.
- If mullion length or load factor exceed chart values, please contact your local Pella sales representative.
- Design charts are not valid for locations where impact forces from wind-borne debris must be considered.
- Chart shows mullion reinforcement requirements using engineered mullion strength values to meet  $L/175 \leq .75"$  deflection, per instructions on page 3.



# Impervia® Combinations

## Two-Way Mullion, Horizontal Door to Rectangle Transom

Maximum Allowable Design Pressure (psf)								
L (in)	W (in)	20	25	30	35	40	45	50
95.5	46.75	A	B	B	C	D	D	D
95.5	53.75	B	B	C	D	D	D	F
95.5	59.75	B	C	C	D	D	F	F
95.5	65.75	B	C	D	D	F	F	G
95.5	71.75	B	C	D	D	F	F	H
95.5	77.75	C	D	D	F	F	G	H
95.5	83.75	C	D	D	F	G	H	J
95.5	89.75	C	D	F	F	H	I	J
95.5	95.75	D	D	F	G	H	J	K
95.5	101.75	D	D	F	H	I	J	K
95.5	107.75	D	F	F	H	J	K	L
107.5	46.75	B	C	D	D	F	F	G
107.5	53.75	C	D	D	F	F	G	H
107.5	59.75	C	D	D	F	G	H	J
107.5	65.75	D	D	F	G	H	J	K
107.5	71.75	D	D	F	H	J	J	K
107.5	77.75	D	F	G	H	J	K	L
107.5	83.75	D	F	H	J	K	L	L
107.5	89.75	D	F	H	J	K	L	L
107.5	95.75	F	G	J	K	L	L	L
107.5	101.75	F	H	J	K	L	L	L
107.5	107.75	F	H	J	L	L	L	—
119.5	46.75	C	D	F	F	H	J	J
119.5	53.75	D	F	F	H	J	K	K
119.5	59.75	D	F	H	J	K	K	L
119.5	65.75	E	F	H	J	K	L	L
119.5	71.75	F	H	J	K	L	L	L
119.5	77.75	F	H	J	L	L	L	—
119.5	83.75	G	J	K	L	L	—	—
119.5	89.75	H	J	K	L	L	—	—
119.5	95.75	H	K	L	L	—	—	—
119.5	101.75	I	K	L	L	—	—	—
119.5	107.75	J	K	L	—	—	—	—



3 1/4" Direct Set  
5" Door

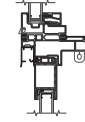

A - Standard Joining Mullion

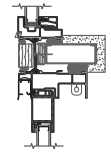

G - 18 ga. 1-3/8" x 3-5/8" Nested Steel Stud and Track

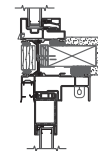

B - (1) 2 x 4 Wood Stud

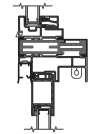

H - 1" Structural Door Mullion

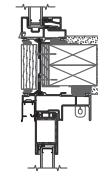

C - (2)-2 x 4 Wood Studs

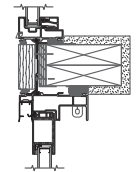

I - (2) 2 x 6 Wood Studs

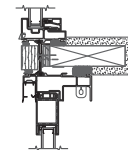

D - (1) 2 X 6 Wood Stud

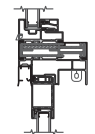

J - 1" Structural Door Mullion w/ 1 Reinforcement



E - 1/2" Structural Door Mullion



K - 1" Structural Door Mullion w/ 2 Reinforcements



F - 1/2" Structural Door Mullion w/ 1 Reinforcement

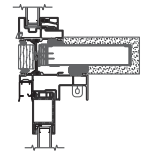

L - 20 ga. 1-3/8" x 6" Nested Steel Stud and Track

- All reinforcing mullions must be properly secured at ends. Wall framing around window opening must be adequate to withstand wind loads transferred from window composite and reinforcing mullions.
- Do not use these accessories or mullions for structural vertical loading. Reinforcing mullions are for wind loading only.
- If mullion length or load factor exceed chart values, please contact your local Pella sales representative.
- Design charts are not valid for locations where impact forces from wind-borne debris must be considered.
- Chart shows mullion reinforcement requirements using engineered mullion strength values to meet  $L/175 \leq .75"$  deflection, per instructions on page 3.



# Impervia® Combinations

## Two-Way Mullion, Horizontal Door to Shape Transom

Maximum Allowable Design Pressure (psf)								
L (in)	W (in)	20	25	30	35	40	45	50
59.25	59.75	A	A	A	A	A	A	A
59.25	65.75	A	A	A	A	A	A	A
59.25	71.75	A	A	A	A	A	A	B
59.25	77.75	A	A	A	A	A	A	B
59.25	83.75	A	A	A	A	A	B	B
59.25	89.75	A	A	A	A	B	B	B
59.25	95.75	A	A	A	A	B	B	B
59.25	101.75	A	A	A	B	B	B	B
59.25	107.50	A	A	A	B	B	B	C
71.25	46.75	A	A	A	A	A	B	B
71.25	53.75	A	A	A	A	B	B	B
71.25	59.75	A	A	A	B	B	B	C
71.25	65.75	A	A	A	B	B	C	C
71.25	71.75	A	A	B	B	B	C	C
71.25	77.75	A	A	B	B	C	C	C
71.25	83.75	A	B	B	B	C	C	D
71.25	89.75	A	B	B	C	C	D	D
71.25	95.75	A	B	B	C	C	D	D
71.25	101.75	B	B	C	C	D	D	D
71.25	107.50	B	B	C	C	D	D	D
79.875	46.75	A	A	A	B	B	C	C
79.875	53.75	A	A	B	B	C	C	C
79.875	59.75	A	B	B	B	C	C	D
79.875	65.75	A	B	B	C	C	D	D
79.875	71.75	A	B	C	C	D	D	D
79.875	77.75	B	B	C	C	D	D	D
79.875	83.75	B	B	C	D	D	D	F
79.875	89.75	B	C	C	D	D	E	F
79.875	95.75	B	C	D	D	D	F	F
79.875	101.75	B	C	D	D	E	F	F
79.875	107.50	C	C	D	D	F	F	G
83.25	46.75	A	A	B	B	C	C	C
83.25	53.75	A	B	B	C	C	C	D
83.25	59.75	A	B	B	C	C	D	D
83.25	65.75	B	B	C	C	D	D	D
83.25	71.75	B	B	C	D	D	D	E
83.25	77.75	B	C	C	D	D	D	F
83.25	83.75	B	C	D	D	E	F	F
83.25	89.75	B	C	D	D	E	F	F
83.25	95.75	C	C	D	D	F	F	G
83.25	101.75	C	D	D	E	F	F	H
83.25	107.50	C	D	D	F	F	G	H
95.25	46.75	B	B	C	D	D	D	D
95.25	53.75	B	C	C	D	D	F	F
95.25	59.75	B	C	D	D	E	F	F
95.25	65.75	C	D	D	D	F	F	G
95.25	71.75	C	D	D	F	F	G	H
95.25	77.75	C	D	D	F	G	H	I
95.25	83.75	D	D	F	F	H	I	J
95.25	89.75	D	D	F	G	H	J	K
95.25	95.75	D	E	F	H	I	J	K
95.25	101.75	D	F	F	H	J	K	K
95.25	107.50	D	F	G	I	J	K	L



3 1/4" Special Shape 5" Door

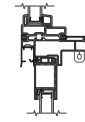

A - Standard Joining Mullion

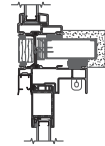

G - 18 ga. 1-3/8" x 3-5/8" Nested Steel Stud and Track

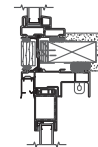

B - (1) 2 x 4 Wood Stud



H - 1" Structural Door Mullion

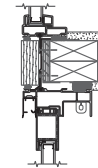

C - (2)-2 x 4 Wood Studs

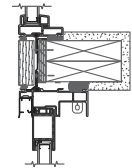

I - (2) 2 x 6 Wood Studs

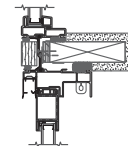

D - (1) 2 X 6 Wood Stud



J - 1" Structural Door Mullion w/ 1 Reinforcement



E - 1/2" Structural Door Mullion



K - 1" Structural Door Mullion w/ 2 Reinforcements



F - 1/2" Structural Door Mullion w/ 1 Reinforcement

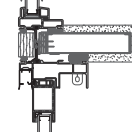

L - 20 ga. 1-3/8" x 6" Nested Steel Stud and Track

- All reinforcing mullions must be properly secured at ends. Wall framing around window opening must be adequate to withstand wind loads transferred from window composite and reinforcing mullions.
- Do not use these accessories or mullions for structural vertical loading. Reinforcing mullions are for wind loading only.
- If mullion length or load factor exceed chart values, please contact your local Pella sales representative.
- Design charts are not valid for locations where impact forces from wind-borne debris must be considered.
- Chart shows mullion reinforcement requirements using engineered mullion strength values to meet  $L/175 \leq .75"$  deflection, per instructions on page 3.



# Impervia® Combinations

## Three-Way Mullion, Door to Two Transoms Horizontal Structure

Maximum Allowable Design Pressure (psf)								
L (in)	W (in)	20	25	30	35	40	45	50
59.25	65.75	A	A	A	A	A	A	A
59.25	71.75	A	A	A	A	A	A	B
59.25	77.75	A	A	A	A	A	B	B
59.25	83.75	A	A	A	A	A	B	B
59.25	89.75	A	A	A	A	B	B	B
59.25	95.75	A	A	A	A	B	B	B
59.25	101.75	A	A	A	B	B	B	C
59.25	107.75	A	A	A	B	B	B	C
71.25	46.75	A	A	A	A	A	B	B
71.25	53.75	A	A	A	A	B	B	B
71.25	59.75	A	A	A	B	B	B	C
71.25	65.75	A	A	A	B	B	C	C
71.25	71.75	A	A	B	B	B	C	C
71.25	77.75	A	A	B	B	C	C	D
71.25	83.75	A	B	B	C	C	C	D
71.25	89.75	A	B	B	C	C	D	D
71.25	95.75	A	B	B	C	C	D	D
71.25	101.75	B	B	C	C	D	D	D
71.25	107.75	B	B	C	C	D	D	D
79.875	46.75	A	A	A	B	B	C	C
79.875	53.75	A	A	B	B	C	C	C
79.875	59.75	A	B	B	C	C	C	D
79.875	65.75	A	B	B	C	C	D	D
79.875	71.75	B	B	C	C	D	D	D
79.875	77.75	B	B	C	C	D	D	D
79.875	83.75	B	C	C	D	D	D	F
79.875	89.75	B	C	C	D	D	E	F
79.875	95.75	B	C	D	D	D	F	F
79.875	101.75	B	C	D	D	F	F	F
79.875	107.75	C	C	D	D	F	F	G
83.25	46.75	A	A	B	B	C	C	C
83.25	53.75	A	B	B	C	C	D	D
83.25	59.75	A	B	B	C	C	D	D
83.25	65.75	B	B	C	C	D	D	D
83.25	71.75	B	B	C	D	D	D	F
83.25	77.75	B	C	C	D	D	D	F
83.25	83.75	B	C	D	D	D	F	F
83.25	89.75	B	C	D	D	F	F	F
83.25	95.75	C	C	D	D	F	F	G
83.25	101.75	C	D	D	E	F	F	H
83.25	107.75	C	D	D	F	F	G	H

Continued on next page

3 1/4" Direct Set  
5" Door

3 1/4" Direct Set  
5" Door



A - Standard Joining Mullion

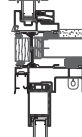

G - 18 ga. 1-3/8" x 3-5/8" Nested Steel Stud and Track



B - (1) 2 x 4 Wood Stud

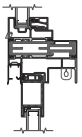

H - 1" Structural Door Mullion



B - (1) 2 x 4 Wood Stud

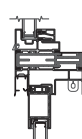

H - 1" Structural Door Mullion



C - (2)-2 x 4 Wood Studs

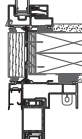

I - (2) 2 x 6 Wood Studs



C - (2)-2 x 4 Wood Studs

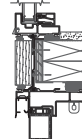

I - (2) 2 x 6 Wood Studs



D - (1) 2 X 6 Wood Stud



J - 1" Structural Door Mullion w/ 1 Reinforcement

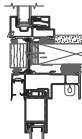

D - (1) 2 X 6 Wood Stud



J - 1" Structural Door Mullion w/ 1 Reinforcement



E - 1/2" Structural Door Mullion



K - 1" Structural Door Mullion w/ 2 Reinforcements

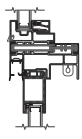

E - 1/2" Structural Door Mullion



K - 1" Structural Door Mullion w/ 2 Reinforcements



F - 1/2" Structural Door Mullion w/ 1 Reinforcement



L - 20 ga. 1-3/8" x 6" Nested Steel Stud and Track



F - 1/2" Structural Door Mullion w/ 1 Reinforcement



L - 20 ga. 1-3/8" x 6" Nested Steel Stud and Track



G - 18 ga. 1-3/8" x 3-5/8" Nested Steel Stud and Track

- All reinforcing mullions must be properly secured at ends. Wall framing around window opening must be adequate to withstand wind loads transferred from window composite and reinforcing mullions.
- Do not use these accessories or mullions for structural vertical loading. Reinforcing mullions are for wind loading only.
- If mullion length or load factor exceed chart values, please contact your local Pella sales representative.
- Design charts are not valid for locations where impact forces from wind-borne debris must be considered.
- Chart shows mullion reinforcement requirements using engineered mullion strength values to meet  $L/175 \leq .75"$  deflection, per instructions on page 3.



# Impervia® Combinations

## Three-Way Mullion, Door to Two Transoms Horizontal Structure

Maximum Allowable Design Pressure (psf)								
L (in)	W (in)	20	25	30	35	40	45	50
95.5	46.75	B	B	C	D	D	D	E
95.5	53.75	B	C	D	D	D	F	F
95.5	59.75	B	C	D	D	F	F	F
95.5	65.75	C	D	D	D	F	F	H
95.5	71.75	C	D	D	F	F	G	H
95.5	77.75	C	D	D	F	G	H	J
95.5	83.75	D	D	F	F	H	I	J
95.5	89.75	D	D	F	G	H	J	K
95.5	95.75	D	F	F	H	I	J	K
95.5	101.75	D	F	G	H	J	K	L
95.5	107.75	D	F	G	I	J	K	L
107.5	46.75	C	D	D	E	F	F	H
107.5	53.75	C	D	D	F	G	H	I
107.5	59.75	D	D	F	F	H	I	J
107.5	65.75	D	E	F	H	I	J	K
107.5	71.75	D	F	G	H	J	K	L
107.5	77.75	D	F	H	J	K	K	L
107.5	83.75	F	F	H	J	K	L	L
107.5	89.75	F	G	I	K	L	L	L
107.5	95.75	F	H	J	K	L	L	L
107.5	101.75	F	H	J	L	L	L	—
107.5	107.75	G	J	K	L	L	L	—
119.5	46.75	D	D	F	G	H	J	K
119.5	53.75	D	F	G	H	J	K	L
119.5	59.75	E	F	H	J	K	L	L
119.5	65.75	F	G	J	K	L	L	L
119.5	71.75	F	H	J	K	L	L	L
119.5	77.75	F	I	K	L	L	L	—
119.5	83.75	H	J	K	L	L	—	—
119.5	89.75	H	K	L	L	L	—	—
119.5	95.75	I	K	L	L	—	—	—
119.5	101.75	J	K	L	L	—	—	—
119.5	107.75	J	L	L	—	—	—	—

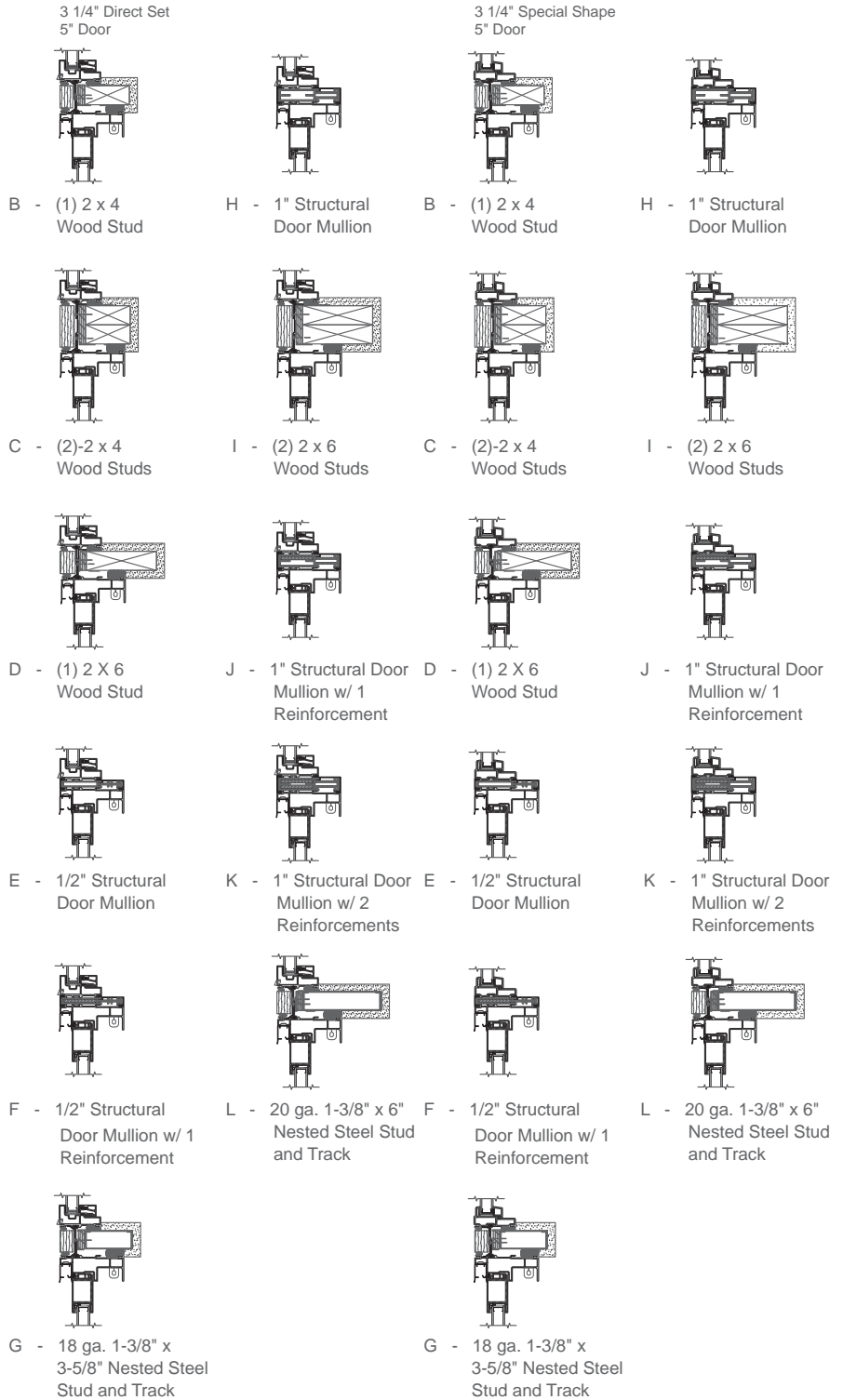

- All reinforcing mullions must be properly secured at ends. Wall framing around window opening must be adequate to withstand wind loads transferred from window composite and reinforcing mullions.
- Do not use these accessories or mullions for structural vertical loading. Reinforcing mullions are for wind loading only.
- If mullion length or load factor exceed chart values, please contact your local Pella sales representative.
- Design charts are not valid for locations where impact forces from wind-borne debris must be considered.
- Chart shows mullion reinforcement requirements using engineered mullion strength values to meet  $L/175 \leq .75"$  deflection, per instructions on page 3.



# Impervia® Combinations

## Four-Way Mullion, Two Doors to Two Transoms Horizontal Structure

Maximum Allowable Design Pressure (psf)								
L (in)	W (in)	20	25	30	35	40	45	50
42	60	B	B	B	B	B	C	C
42	66	B	B	B	B	C	C	C
42	72	B	B	B	C	C	C	C
48	36	B	B	B	B	B	B	B
48	48	B	B	B	B	C	C	C
48	54	B	B	B	B	C	C	C
48	60	B	B	B	C	C	C	C
48	66	B	B	C	C	C	C	C
48	72	B	B	C	C	C	C	C
54	28	B	B	B	B	B	B	B
54	30	B	B	B	B	B	B	B
54	36	B	B	B	B	B	C	C
54	48	B	B	B	C	C	C	C
54	54	B	B	C	C	C	C	C
54	60	B	B	C	C	C	C	C
54	66	B	C	C	C	C	C	D
54	72	B	C	C	C	C	D	D
60	18	B	B	B	B	B	B	B
60	24	B	B	B	B	B	B	B
60	28	B	B	B	B	B	C	C
60	30	B	B	B	B	B	C	C
60	36	B	B	B	C	C	C	C
60	48	B	B	C	C	C	C	C
60	54	B	C	C	C	C	C	D
60	60	B	C	C	C	C	D	D
60	66	C	C	C	C	D	D	E
60	72	C	C	C	D	D	E	E
72	18	B	B	B	B	B	B	C
72	24	B	B	B	B	C	C	C
72	28	B	B	B	C	C	C	C
72	30	B	B	C	C	C	C	C
72	36	B	C	C	C	C	C	D
72	48	C	C	C	C	D	E	E
72	54	C	C	C	D	E	E	E
72	60	C	C	D	E	E	E	F
72	66	C	C	D	E	E	F	F
72	72	C	D	E	E	E	F	F
78	18	B	B	B	B	C	C	C
78	24	B	B	C	C	C	C	C
78	28	B	B	C	C	C	C	C
78	30	B	C	C	C	C	C	D
78	36	C	C	C	C	D	D	E
78	48	C	C	D	D	E	E	E
78	54	C	C	D	E	E	E	F
78	60	C	D	E	E	E	F	F
78	66	C	D	E	E	F	F	F
78	72	D	E	E	F	F	F	F
84	18	B	B	B	C	C	C	C
84	24	B	C	C	C	C	C	D
84	28	B	C	C	C	C	D	D
84	30	C	C	C	C	D	D	D
84	36	C	C	C	D	D	E	E
84	48	C	D	D	E	E	F	F
84	54	C	D	E	E	F	F	F
84	60	D	D	E	E	F	F	F
84	66	D	E	E	F	F	F	G
84	72	D	E	F	F	F	F	H

Continued on next page

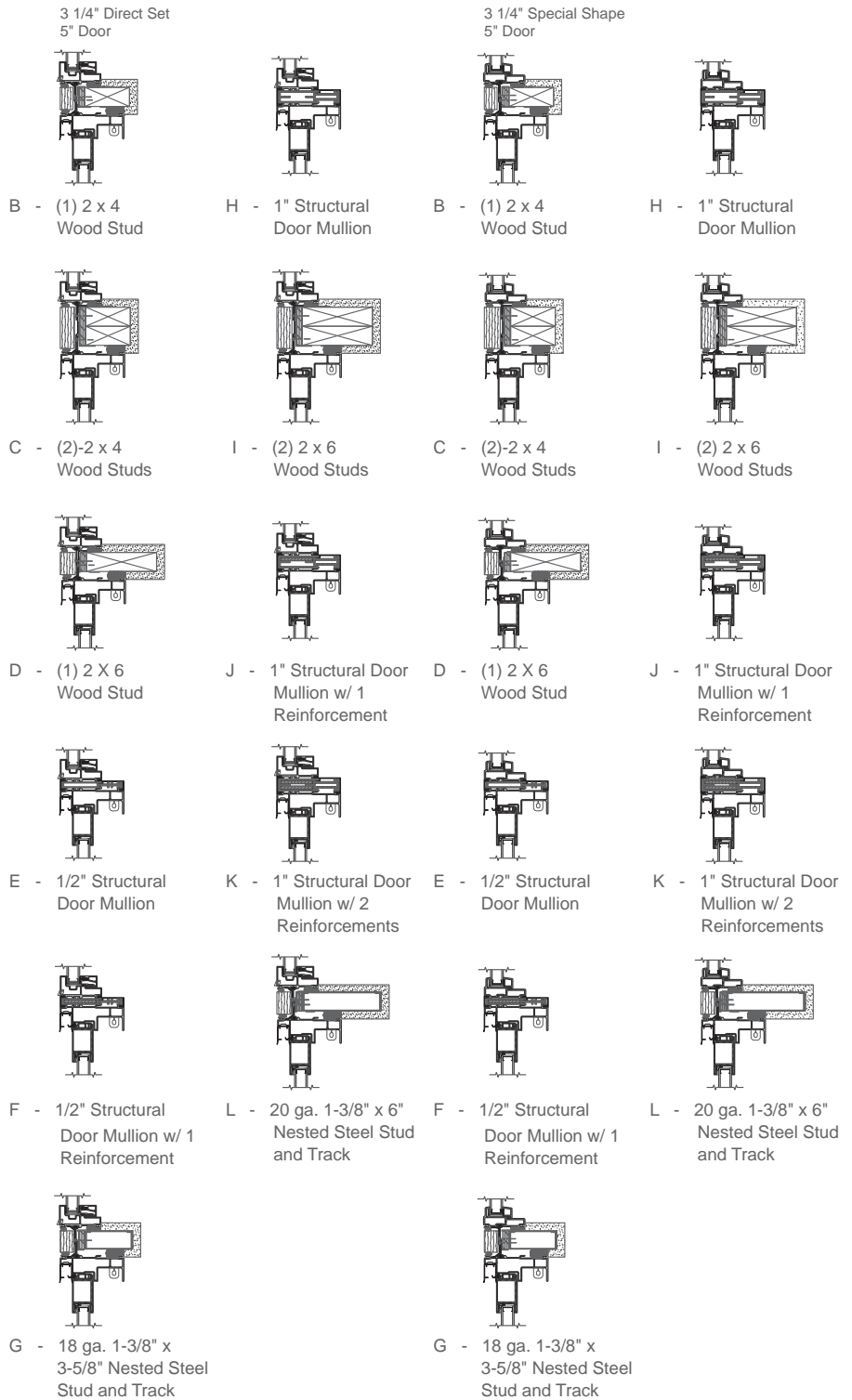

- All reinforcing mullions must be properly secured at ends. Wall framing around window opening must be adequate to withstand wind loads transferred from window composite and reinforcing mullions.
- Do not use these accessories or mullions for structural vertical loading. Reinforcing mullions are for wind loading only.
- If mullion length or load factor exceed chart values, please contact your local Pella sales representative.
- Design charts are not valid for locations where impact forces from wind-borne debris must be considered.
- Chart shows mullion reinforcement requirements using engineered mullion strength values to meet  $L/175 \leq .75"$  deflection, per instructions on page 3.



# Impervia® Combinations

## Four-Way Mullion, Two Doors to Two Transoms Horizontal Structure

Maximum Allowable Design Pressure (psf)								
L (in)	W (in)	20	25	30	35	40	45	50
90	18	B	B	C	C	C	C	C
90	24	C	C	C	C	D	D	D
90	28	C	C	C	D	D	D	E
90	30	C	C	C	D	D	E	E
90	36	C	C	D	D	E	E	E
90	48	D	D	E	E	F	F	F
90	54	D	E	E	F	F	F	G
90	60	D	E	E	F	F	G	H
90	66	D	E	F	F	F	H	H
90	72	E	E	F	F	G	H	J
96	18	B	C	C	C	C	D	D
96	24	C	C	C	D	D	D	E
96	28	C	C	D	D	D	E	E
96	30	C	C	D	D	E	E	E
96	36	C	D	D	E	E	F	F
96	48	D	E	E	F	F	F	G
96	54	D	E	F	F	F	H	H
96	60	E	E	F	F	G	H	J
96	66	E	F	F	G	H	I	J
96	72	E	F	F	H	I	J	K
108	18	C	C	D	D	D	D	D
108	24	C	D	D	D	E	F	F
108	28	D	D	D	E	F	F	F
108	30	D	D	D	E	F	F	F
108	36	D	D	F	F	F	G	H
108	48	E	F	F	G	H	J	J
108	54	F	F	G	H	J	J	K
108	60	F	F	H	J	J	K	L
108	66	F	G	H	J	K	L	L
108	72	F	H	J	K	K	L	L

3 1/4" Direct Set 5" Door

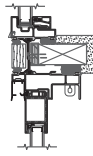

B - (1) 2 x 4 Wood Stud



H - 1" Structural Door Mullion

3 1/4" Special Shape 5" Door



B - (1) 2 x 4 Wood Stud

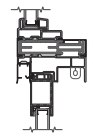

H - 1" Structural Door Mullion



C - (2)-2 x 4 Wood Studs

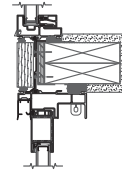

I - (2) 2 x 6 Wood Studs

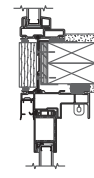

C - (2)-2 x 4 Wood Studs

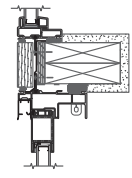

I - (2) 2 x 6 Wood Studs

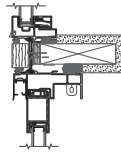

D - (1) 2 X 6 Wood Stud

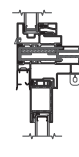

J - 1" Structural Door Mullion w/ 1 Reinforcement

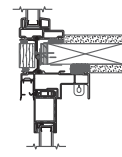

D - (1) 2 X 6 Wood Stud



J - 1" Structural Door Mullion w/ 1 Reinforcement

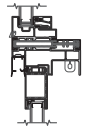

E - 1/2" Structural Door Mullion



K - 1" Structural Door Mullion w/ 2 Reinforcements

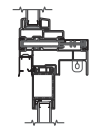

E - 1/2" Structural Door Mullion



K - 1" Structural Door Mullion w/ 2 Reinforcements



F - 1/2" Structural Door Mullion w/ 1 Reinforcement

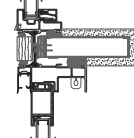

L - 20 ga. 1-3/8" x 6" Nested Steel Stud and Track



F - 1/2" Structural Door Mullion w/ 1 Reinforcement

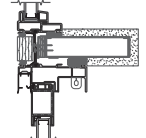

L - 20 ga. 1-3/8" x 6" Nested Steel Stud and Track



G - 18 ga. 1-3/8" x 3-5/8" Nested Steel Stud and Track

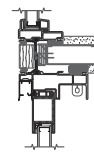

G - 18 ga. 1-3/8" x 3-5/8" Nested Steel Stud and Track

- All reinforcing mullions must be properly secured at ends. Wall framing around window opening must be adequate to withstand wind loads transferred from window composite and reinforcing mullions.
- Do not use these accessories or mullions for structural vertical loading. Reinforcing mullions are for wind loading only.
- If mullion length or load factor exceed chart values, please contact your local Pella sales representative.
- Design charts are not valid for locations where impact forces from wind-borne debris must be considered.
- Chart shows mullion reinforcement requirements using engineered mullion strength values to meet  $L/175 \leq .75"$  deflection, per instructions on page 3.



# Impervia® Combinations

## Four-Way Mullion, Two Doors to Two Transoms Vertical Structure

Maximum Allowable Design Pressure (psf)								
L (in)	W (in)	20	25	30	35	40	45	50
42	60	B	B	B	B	B	C	C
42	66	B	B	B	B	C	C	C
42	72	B	B	B	C	C	C	C
48	36	B	B	B	B	B	B	B
48	48	B	B	B	B	C	C	C
48	54	B	B	B	B	C	C	C
48	60	B	B	B	C	C	C	C
48	66	B	B	C	C	C	C	C
48	72	B	B	C	C	C	C	C
54	28	B	B	B	B	B	B	B
54	30	B	B	B	B	B	B	B
54	36	B	B	B	B	B	C	C
54	48	B	B	B	C	C	C	C
54	54	B	B	C	C	C	C	C
54	60	B	B	C	C	C	C	C
54	66	B	C	C	C	C	C	D
54	72	B	C	C	C	C	D	D
60	18	B	B	B	B	B	B	B
60	24	B	B	B	B	B	B	B
60	28	B	B	B	B	B	C	C
60	30	B	B	B	B	B	C	C
60	36	B	B	B	C	C	C	C
60	48	B	B	C	C	C	C	C
60	54	B	C	C	C	C	C	D
60	60	B	C	C	C	C	D	D
60	66	C	C	C	C	D	D	G
60	72	C	C	C	D	D	G	G
72	18	B	B	B	B	B	B	C
72	24	B	B	B	B	C	C	C
72	28	B	B	B	C	C	C	C
72	30	B	B	C	C	C	C	C
72	36	B	C	C	C	C	C	D
72	48	C	C	C	C	D	G	G
72	54	C	C	C	D	G	G	G
72	60	C	C	D	G	G	G	G
72	66	C	C	D	G	G	G	G
72	72	C	D	G	G	G	G	G
78	18	B	B	B	B	C	C	C
78	24	B	B	C	C	C	C	C
78	28	B	B	C	C	C	C	C
78	30	B	C	C	C	C	C	D
78	36	C	C	C	C	D	D	G
78	48	C	C	D	D	G	G	G
78	54	C	C	D	G	G	G	G
78	60	C	D	G	G	G	G	G
78	66	C	D	G	G	G	G	G
78	72	D	G	G	G	G	G	L
84	18	B	B	B	C	C	C	C
84	24	B	C	C	C	C	C	D
84	28	B	C	C	C	C	D	D
84	30	C	C	C	C	D	D	D
84	36	C	C	C	D	D	G	G
84	48	C	D	D	G	G	G	G
84	54	C	D	G	G	G	G	G
84	60	D	D	G	G	G	G	I
84	66	D	G	G	G	G	G	L
84	72	D	G	G	G	G	L	L

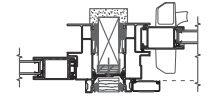
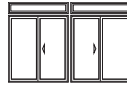

B - (1) 2 x 4  
Wood Stud

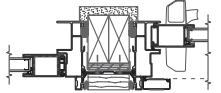

C - (2)-2 x 4  
Wood Studs

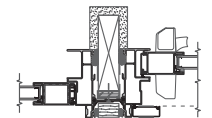

D - (1) 2 X 6  
Wood Stud

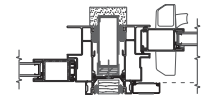

G - 18 ga. 1-3/8" x  
3-5/8" Nested Steel  
Stud and Track

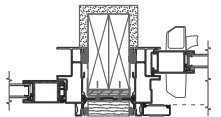

I - (2) 2 x 6  
Wood Studs

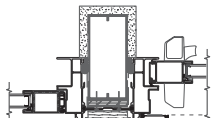

L - 20 ga. 1-3/8" x 6"  
Nested Steel Stud  
and Track

Continued on next page

Note - only field structure options are shown as Pella structural mullions are not to be used as vertical through structure at four way mullions.

- All reinforcing mullions must be properly secured at ends. Wall framing around window opening must be adequate to withstand wind loads transferred from window composite and reinforcing mullions.
- Do not use these accessories or mullions for structural vertical loading. Reinforcing mullions are for wind loading only.
- If mullion length or load factor exceed chart values, please contact your local Pella sales representative.
- Design charts are not valid for locations where impact forces from wind-borne debris must be considered.
- Chart shows mullion reinforcement requirements using engineered mullion strength values to meet  $L/175 \leq .75"$  deflection, per instructions on page 3.



# Impervia® Combinations

## Four-Way Mullion, Two Doors to Two Transoms Vertical Structure

Maximum Allowable Design Pressure (psf)								
L (in)	W (in)	20	25	30	35	40	45	50
90	18	B	B	C	C	C	C	C
90	24	C	C	C	C	D	D	D
90	28	C	C	C	D	D	D	G
90	30	C	C	C	D	D	G	G
90	36	C	C	D	D	G	G	G
90	48	D	D	G	G	G	G	G
90	54	D	G	G	G	G	G	L
90	60	D	G	G	G	G	L	L
90	66	D	G	G	G	I	L	L
90	72	G	G	G	G	L	L	L
96	18	B	C	C	C	C	D	D
96	24	C	C	C	D	D	D	G
96	28	C	C	D	D	D	G	G
96	30	C	C	D	D	G	G	G
96	36	C	D	D	G	G	G	G
96	48	D	G	G	G	G	G	L
96	54	D	G	G	G	G	L	L
96	60	G	G	G	G	L	L	L
96	66	G	G	G	I	L	L	L
96	72	G	G	G	L	L	L	—
108	18	C	C	D	D	D	D	D
108	24	C	D	D	D	G	G	G
108	28	D	D	D	D	G	G	G
108	30	D	D	D	G	G	G	G
108	36	D	D	G	G	G	G	I
108	48	G	G	G	G	L	L	L
108	54	G	G	G	L	L	L	L
108	60	G	G	I	L	L	L	—
108	66	G	G	L	L	L	—	—
108	72	G	I	L	L	—	—	—

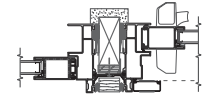
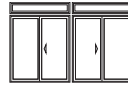

B - (1) 2 x 4  
Wood Stud

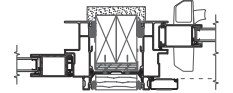

C - (2)-2 x 4  
Wood Studs

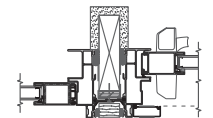

D - (1) 2 X 6  
Wood Stud

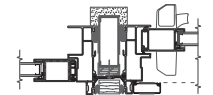

G - 18 ga. 1-3/8" x  
3-5/8" Nested Steel  
Stud and Track

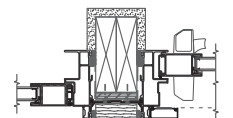

I - (2) 2 x 6  
Wood Studs

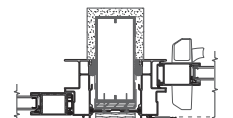

L - 20 ga. 1-3/8" x 6"  
Nested Steel Stud  
and Track

Note - only field structure options are shown as Pella structural mullions are not to be used as vertical through structure at four way mullions.

- All reinforcing mullions must be properly secured at ends. Wall framing around window opening must be adequate to withstand wind loads transferred from window composite and reinforcing mullions.
- Do not use these accessories or mullions for structural vertical loading. Reinforcing mullions are for wind loading only.
- If mullion length or load factor exceed chart values, please contact your local Pella sales representative.
- Design charts are not valid for locations where impact forces from wind-borne debris must be considered.
- Chart shows mullion reinforcement requirements using engineered mullion strength values to meet  $L/175 \leq .75"$  deflection, per instructions on page 3.