



Product Selection Guide

Size and Performance Data F-FW-2

Sound Transmission Class and Outdoor-Indoor Transmission Class F-FW-2

Features and Options F-FW-3

Glazing Performance F-FW-4

Grilles Types F-FW-9

Size Tables

 Single Unit..... F-FW-10

 Two-Wide Units..... F-FW-12

 Three-Wide Units..... F-FW-14

Special Sizes..... F-FW-15

Composite Assemblies..... F-FW-15

Design Data..... F-FW-16

Detailed Product Descriptions F-FW-19

Unit Sections

Block Frame..... F-FW-21

Integral Nailing Fin Frame / Flush Flange Frame..... F-FW-22

Document Navigation Tips:

Items listed in the table of contents above are active links that will take you to the corresponding page. The Pella logo on each page is a link back to this table of contents. Bookmarks are also included in this PDF document and are available as an additional navigation option.

Supporting documents for this product:

Test Reports:

https://media.pella.com/professional/adm/CertificationReports/Test_Reports_IMP.pdf?utm_source=pdfdoc

CSI Specs (readable using Microsoft Word or other text editing application):

https://media.pella.com/professional/adm/Fiberglass-CSI_Specs/08572_FW.rtf?utm_source=pdfdoc

AIA Masterspec (readable using Microsoft Word or other text editing application):

https://media.pella.com/professional/adm/Fiberglass-CSI_Specs/085413_fl.doc?utm_source=pdfdoc

Detailed Product Description (readable using Microsoft Word or other text editing application):

https://media.pella.com/professional/adm/Fiberglass/F2-FW.rtf?utm_source=pdfdoc

Size Tables (requires appropriate CAD software to read and use):

http://media.pella.com/professional/adm/Fiberglass/IMP-FW-Elev_D.dwg?utm_source=pdfdoc

CAD cross sections (requires appropriate CAD software to read and use):

https://media.pella.com/professional/adm/Fiberglass/IMP-FW-Details_D.dwg?utm_source=pdfdoc

3D & BIM (requires appropriate software to read and use):

https://media.pella.com/professional/adm/RevitFiles/Imp-Revit/Pella_Impervia-Fixed_Window.zip?utm_source=pdfdoc

Combination Recommendations:

https://media.pella.com/professional/adm/Fiberglass/F2_Combinations.pdf?utm_source=pdfdoc

Installation Details:

https://media.pella.com/professional/adm/Fiberglass/Pella-Impervia_InstallationDetails.pdf?utm_source=pdfdoc

Microsoft and Microsoft Word are registered trademarks of Microsoft Corp.



	Block Frame	Integral Nailing Fin	Flange Frame
Sizes			
Standard	●	●	●
Special sizes available	●	●	●
Performance¹			
Meets or Exceeds AAMA/WDMA Ratings	F-CW30 — F-CW50 Hallmark Certified	F-CW30 — F-CW50 Hallmark Certified	F-CW30 — F-CW50 Hallmark Certified
Air Infiltration (cfm/ft ² of frame @ 1.57 psf wind pressure)	0.01	0.01	0.01
Water Resistance	7.5 psf	7.5 psf	7.5 psf
Design Pressure	30 - 50 psf	30 - 50 psf	30 - 50 psf
Other Performance Criteria			
Forced Entry Resistance Level (Minimum Security Grade) ²	40	40	40

Sound Transmission Class and Outdoor-Indoor Transmission Class

Frame Size Tested ³	Glazing System			STC Rating	OITC Rating
	Overall Glazing Thickness	Exterior Glass Thickness	Interior Glass Thickness		
Fixed Window					
47-1/2" x 59-1/2"	11/16"	3mm	3mm	27	23
47-1/2" x 59-1/2"	11/16"	3mm	5mm	32	27
47-1/2" x 59-1/2"	11/16"	3mm	6mm PVB Laminated	33	28
47-1/2" x 59-1/2"	11/16"	4mm	7mm PVB Laminated	33	28

(1) Composite units are not AAMA/WDMA performance certified. Pella Impervia composites are engineered to meet performance class and grade shown in the design data tables.

(2) The higher the level, the greater the product's ability to resist forced entry.

(3) ASTM E 1425 defines standard sizes for acoustical testing. Ratings achieved at that size are representative of all sizes of the same configuration.

Open frame no sash available for PTAC (Packaged Terminal Air Conditioner) applications.



	Block Frame	Integral Nailing Fin	Flange Frame
Glazing			
Glazing Type			
Dual-pane Insulating Glass	S	S	S
Insulated Glass Options / Low-E Types			
Clear Insulating Glass (no Low-E coating)	S	S	S
Advanced Low-E Insulating Glass	O	O	O
SunDefense™ Low-E Insulating Glass	O	O	O
SunDefense+ Low-E Insulating Glass	O	O	O
AdvancedComfort Low-E Insulating Glass	O	O	O
NaturalSun Low-E Insulating Glass	O	O	O
NaturalSun+ Low-E Insulating Glass	O	O	O
Additional Glass Options			
Annealed Glass	S	S	S
Tempered Glass ¹	O	O	O
Noise reduction glass (3/5mm, 4/6mm combinations)	O	O	O
Noise reduction laminated glass (non-impact)	O	O	O
Tinted glass (Bronze, Gray, Green) Advanced Low-E	O	O	O
Obscure Glass ²	O	O	O
Gas Fill / High Altitude			
Argon	S	S	S
High Altitude	O	O	O
High Altitude with argon	O	O	O
Exterior / Interior Factory Pre-finish Colors			
Powder-coat White	S	S	S
Powder-Coat Brown, Black, Tan or Morning Sky Gray	O	O	O
Powder-Coat Dual-color (Brown, Black, Tan or Morning Sky Gray Exterior with White interior)	O	—	O
Grilles			
Grilles-Between-the-Glass			
Traditional, Prairie, Top Row and Special	O	O	O

S = Standard; O = Optional; (—) = Not Applicable

(1) Tempered glass not available on 6-0/5-6 or 6-0/6-0 fixed.

(2) Contact your local Pella sales representative for current offering.



Glazing Thickness	Type of Glazing	NFRC Certified Product #	Glass (mm)		Gap Fill	Performance Values ¹				Shaded Areas Meet ENERGY STAR® Performance Criteria in Zones Shown					
			Ext.	Int.		U-Factor	SHGC	VLT	CR	U. S.				Canada ²	
										Zone				ER	Zone
Fixed										N	NC	SC	S	CA	
11/16"	Clear IG	PEL-N-104-01142-00004	2.5	2.5	air	0.47	0.63	0.65	44						
	with grilles-between-the-glass	PEL-N-104-01143-00004				0.47	0.56	0.58	44						
11/16"	Clear IG	PEL-N-104-01142-00002	3	3	air	0.47	0.62	0.64	44						
	with grilles-between-the-glass	PEL-N-104-01143-00002				0.47	0.55	0.57	44						
11/16"	Clear IG	PEL-N-104-01152-00002	5	5	air	0.49	0.59	0.63	42						
	with grilles-between-the-glass	PEL-N-104-01153-00002				0.49	0.53	0.56	42						
11/16"	Advanced Low-E IG	PEL-N-104-01234-00004	2.5	2.5	argon	0.29	0.30	0.55	60						
	with grilles-between-the-glass	PEL-N-104-01235-00004				0.29	0.27	0.49	60						
11/16"	Advanced Low-E IG	PEL-N-104-01234-00002	3	3	argon	0.29	0.29	0.55	60						
	with grilles-between-the-glass	PEL-N-104-01235-00002				0.29	0.27	0.49	60						
11/16"	Advanced Low-E IG	PEL-N-104-01244-00002	5	5	argon	0.31	0.29	0.54	56						
	with grilles-between-the-glass	PEL-N-104-01245-00002				0.32	0.26	0.48	56						
11/16"	SunDefense™ IG	PEL-N-104-01274-00004	2.5	2.5	argon	0.28	0.22	0.51	60			SC	S		
	with grilles-between-the-glass	PEL-N-104-01275-00004				0.28	0.20	0.46	60			SC	S		
11/16"	SunDefense™ IG	PEL-N-104-01274-00002	3	3	argon	0.28	0.22	0.51	60			SC	S		
	with grilles-between-the-glass	PEL-N-104-01275-00002				0.28	0.20	0.45	60			SC	S		
11/16"	SunDefense™ IG	PEL-N-104-01284-00002	5	5	argon	0.31	0.22	0.50	56				S		
	with grilles-between-the-glass	PEL-N-104-01285-00002				0.32	0.20	0.44	56				S		
11/16"	SunDefense+ IG	PEL-N-104-01404-00001	2.5	2.5	argon	0.25	0.22	0.50	48						
	with grilles-between-the-glass	PEL-N-104-01405-00001				0.25	0.20	0.45	48						
11/16"	SunDefense+ IG	PEL-N-104-01408-00001	3	3	argon	0.25	0.22	0.50	47						
	with grilles-between-the-glass	PEL-N-104-01409-00001				0.25	0.20	0.44	47						
11/16"	SunDefense+ IG	PEL-N-104-01416-00001	5	5	argon	0.27	0.22	0.49	43						
	with grilles-between-the-glass	PEL-N-104-01417-00001				0.29	0.20	0.43	43						
11/16"	AdvancedComfort Low-E IG	PEL-N-104-01310-00004	2.5	2.5	argon	0.25	0.29	0.54	43		NC				
	with grilles-between-the-glass	PEL-N-104-01311-00004				0.25	0.26	0.48	43		NC				
11/16"	AdvancedComfort Low-E IG	PEL-N-104-01310-00002	3	3	argon	0.25	0.29	0.54	43		NC				
	with grilles-between-the-glass	PEL-N-104-01311-00002				0.25	0.26	0.48	43		NC				
11/16"	AdvancedComfort Low-E IG	PEL-N-104-01316-00002	5	5	argon	0.27	0.28	0.52	43						
	with grilles-between-the-glass	PEL-N-104-01317-00002				0.27	0.26	0.47	43						
11/16"	NaturalSun Low-E IG	PEL-N-104-01198-00004	2.5	2.5	argon	0.30	0.55	0.63	59						
	with grilles-between-the-glass	PEL-N-104-01199-00004				0.30	0.50	0.56	59						
11/16"	NaturalSun Low-E IG	PEL-N-104-01198-00002	3	3	argon	0.30	0.54	0.62	59						
	with grilles-between-the-glass	PEL-N-104-01199-00002				0.30	0.49	0.55	59						
11/16"	NaturalSun Low-E IG	PEL-N-104-01204-00002	5	5	argon	0.32	0.52	0.61	55						
	with grilles-between-the-glass	PEL-N-104-01205-00002				0.32	0.47	0.54	55						
11/16"	NaturalSun+ Low-E IG	PEL-N-104-01432-00001	2.5	2.5	argon	0.26	0.50	0.61	47	N				35	CA
	with grilles-between-the-glass	PEL-N-104-01433-00001				0.26	0.45	0.55	47	N					
11/16"	NaturalSun+ Low-E IG	PEL-N-104-01436-00001	3	3	argon	0.26	0.49	0.61	46	N				35	CA
	with grilles-between-the-glass	PEL-N-104-01437-00001				0.26	0.44	0.54	46	N					
11/16"	NaturalSun+ Low-E IG	PEL-N-104-01444-00001	5	5	argon	0.28	0.47	0.59	42						
	with grilles-between-the-glass	PEL-N-104-01445-00001				0.30	0.42	0.53	42						

R-Value = 1/U-Factor
 SHGC = Solar Heat Gain Coefficient
 VLT % = Visible Light Transmission
 CR = Condensation Resistance
 ER = Canadian Energy Rating

(1) Glazing performance values are calculated based on NFRC 100, NFRC 200 and NFRC 500. ENERGY STAR® values are updated to 2023 (version 7) criteria.
 (2) The values shown are based on Canada's updated ENERGY STAR® 2020 initiative. For center-glass values, see the Product Performance section. Visit www.energystar.gov for Energy Star guidelines.

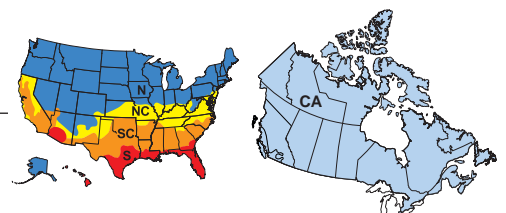



Impervia® Fixed Windows

Glazing Performance – Total Unit

Glazing Thickness	Type of Glazing	NFRC Certified Product #	Glass (mm)		Gap Fill	Performance Values ¹				Shaded Areas Meet ENERGY STAR® Performance Criteria in Zones Shown								
			Ext.	Int.		U-Factor	SHGC	VLT	CR	U. S.			Canada ²					
										Zone			ER	Zone				
Fixed – with Foam Insulation										N	NC	SC	S					
11/16"	Advanced Low-E IG	PEL-N-104-01002-00004	2.5	2.5	argon	0.26	0.30	0.55	60									
	with grilles-between-the-glass	PEL-N-104-01003-00004				0.26	0.27	0.49	60									
11/16"	Advanced Low-E IG	PEL-N-104-01002-00002	3	3	argon	0.26	0.29	0.55	60									
	with grilles-between-the-glass	PEL-N-104-01003-00002				0.26	0.27	0.49	60									
11/16"	Advanced Low-E IG	PEL-N-104-01012-00002	5	5	argon	0.28	0.29	0.54	56									
	with grilles-between-the-glass	PEL-N-104-01013-00002				0.29	0.26	0.48	56									
11/16"	SunDefense™ IG	PEL-N-104-01042-00004	2.5	2.5	argon	0.25	0.22	0.51	61		NC	SC	S					
	with grilles-between-the-glass	PEL-N-104-01043-00004				0.25	0.20	0.46	61		NC	SC	S					
11/16"	SunDefense IG	PEL-N-104-01042-00002	3	3	argon	0.25	0.22	0.51	61		NC	SC	S					
	with grilles-between-the-glass	PEL-N-104-01043-00002				0.25	0.20	0.45	61		NC	SC	S					
11/16"	SunDefense IG	PEL-N-104-01052-00002	5	5	argon	0.28	0.22	0.50	57				SC	S				
	with grilles-between-the-glass	PEL-N-104-01053-00002				0.29	0.20	0.44	57					S				
11/16"	SunDefense+ IG	PEL-N-104-01516-00001	2.5	2.5	argon	0.22	0.22	0.50	49	N								
	with grilles-between-the-glass	PEL-N-104-01517-00001				0.22	0.20	0.45	49	N								
11/16"	SunDefense+ IG	PEL-N-104-01520-00001	3	3	argon	0.22	0.22	0.50	48	N								
	with grilles-between-the-glass	PEL-N-104-01521-00001				0.22	0.20	0.44	48	N								
11/16"	SunDefense+ IG	PEL-N-104-01528-00001	5	5	argon	0.24	0.22	0.49	43									
	with grilles-between-the-glass	PEL-N-104-01529-00001				0.26	0.20	0.43	43									
11/16"	AdvancedComfort Low-E IG	PEL-N-104-01078-00004	2.5	2.5	argon	0.22	0.29	0.54	39	N	NC							
	with grilles-between-the-glass	PEL-N-104-01079-00004				0.22	0.26	0.48	39	N	NC							
11/16"	AdvancedComfort Low-E IG	PEL-N-104-01078-00002	3	3	argon	0.22	0.29	0.54	39	N	NC							
	with grilles-between-the-glass	PEL-N-104-01079-00002				0.22	0.26	0.48	39	N	NC							
11/16"	AdvancedComfort Low-E IG	PEL-N-104-01084-00002	5	5	argon	0.24	0.28	0.52	43			NC						
	with grilles-between-the-glass	PEL-N-104-01085-00002				0.24	0.26	0.47	43			NC						
11/16"	NaturalSun Low-E IG	PEL-N-104-00966-00004	2.5	2.5	argon	0.27	0.55	0.63	60							37	CA	
	with grilles-between-the-glass	PEL-N-104-00967-00004				0.27	0.50	0.56	60							34	CA	
11/16"	NaturalSun Low-E IG	PEL-N-104-00966-00002	3	3	argon	0.27	0.54	0.62	60							36	CA	
	with grilles-between-the-glass	PEL-N-104-00967-00002				0.27	0.49	0.55	60									
11/16"	NaturalSun Low-E IG	PEL-N-104-00972-00002	5	5	argon	0.29	0.52	0.61	56									
	with grilles-between-the-glass	PEL-N-104-00973-00002				0.29	0.47	0.54	56									
11/16"	NaturalSun+ Low-E IG	PEL-N-104-01544-00001	2.5	2.5	argon	0.23	0.50	0.61	47	N						39	CA	
	with grilles-between-the-glass	PEL-N-104-01545-00001				0.23	0.45	0.55	47	N						36	CA	
11/16"	NaturalSun+ Low-E IG	PEL-N-104-01548-00001	3	3	argon	0.23	0.49	0.61	46	N						38	CA	
	with grilles-between-the-glass	PEL-N-104-01549-00001				0.23	0.44	0.54	46	N						35	CA	
11/16"	NaturalSun+ Low-E IG	PEL-N-104-01556-00001	5	5	argon	0.25	0.47	0.59	42	N						35	CA	
	with grilles-between-the-glass	PEL-N-104-01557-00001				0.27	0.42	0.53	42									

R-Value = 1/U-Factor
 SHGC = Solar Heat Gain Coefficient
 VLT % = Visible Light Transmission
 CR = Condensation Resistance
 ER = Canadian Energy Rating

(1) Glazing performance values are calculated based on NFRC 100, NFRC 200 and NFRC 500. ENERGY STAR® values are updated to 2023 (version 7) criteria.
 (2) The values shown are based on Canada's updated ENERGY STAR® 2020 initiative. For center-glass values, see the Product Performance section. Visit www.energystar.gov for Energy Star guidelines.

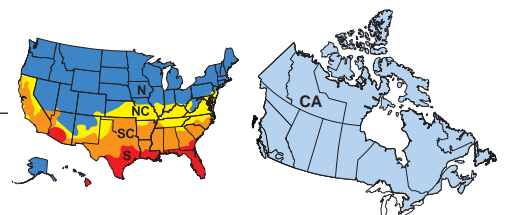



Glazing Thickness	Type of Glazing	NFRC Certified Product #	Glass (mm)		Gap Fill	Performance Values ¹				Shaded Areas Meet ENERGY STAR® Performance Criteria in Zones Shown						
			Ext.	Int.		U-Factor	SHGC	VLT	CR	U. S.		Canada ²				
										Zone		ER	Zone			
Fixed – High Altitude Glazing										N	NC	SC	S	CA		
11/16"	(HA) Advanced Low-E IG	PEL-N-104-01214-00004	2.5	2.5	air	0.33	0.30	0.55	56							
	with grilles-between-the-glass	PEL-N-104-01215-00004				0.33	0.27	0.49	56							
11/16"	(HA) Advanced Low-E IG	PEL-N-104-01214-00002	3	3	air	0.33	0.30	0.55	56							
	with grilles-between-the-glass	PEL-N-104-01215-00002				0.33	0.27	0.49	56							
11/16"	(HA) Advanced Low-E IG	PEL-N-104-01224-00002	5	5	air	0.36	0.30	0.54	51							
	with grilles-between-the-glass	PEL-N-104-01225-00002				0.37	0.27	0.48	51							
11/16"	(HA) SunDefense IG	PEL-N-104-01254-00004	2.5	2.5	air	0.32	0.22	0.51	56					S		
	with grilles-between-the-glass	PEL-N-104-01255-00004				0.32	0.20	0.46	56					S		
11/16"	(HA) SunDefense IG	PEL-N-104-01254-00002	3	3	air	0.32	0.22	0.51	56					S		
	with grilles-between-the-glass	PEL-N-104-01255-00002				0.32	0.20	0.45	56					S		
11/16"	(HA) SunDefense IG	PEL-N-104-01264-00002	5	5	air	0.36	0.23	0.50	52							
	with grilles-between-the-glass	PEL-N-104-01265-00002				0.37	0.21	0.44	52							
11/16"	(HA) SunDefense+ IG	PEL-N-104-01402-00001	2.5	2.5	air	0.27	0.22	0.50	44							
	with grilles-between-the-glass	PEL-N-104-01403-00001				0.27	0.20	0.45	44							
11/16"	(HA) SunDefense+ IG	PEL-N-104-01406-00001	3	3	air	0.28	0.22	0.50	43							
	with grilles-between-the-glass	PEL-N-104-01407-00001				0.28	0.20	0.44	43							
11/16"	(HA) SunDefense+ IG	PEL-N-104-01414-00001	5	5	air	0.31	0.22	0.49	39							
	with grilles-between-the-glass	PEL-N-104-01415-00001				0.32	0.20	0.43	39							
11/16"	(HA) AdvancedComfort Low-E IG	PEL-N-104-01294-00004	2.5	2.5	air	0.28	0.29	0.54	43							
	with grilles-between-the-glass	PEL-N-104-01295-00004				0.28	0.26	0.48	43							
11/16"	(HA) AdvancedComfort Low-E IG	PEL-N-104-01294-00002	3	3	air	0.28	0.29	0.54	43							
	with grilles-between-the-glass	PEL-N-104-01295-00002				0.28	0.26	0.48	43							
11/16"	(HA) AdvancedComfort Low-E IG	PEL-N-104-01300-00002	5	5	air	0.28	0.28	0.52	39							
	with grilles-between-the-glass	PEL-N-104-01301-00002				0.28	0.26	0.47	39							
11/16"	(HA) NaturalSun Low-E IG	PEL-N-104-01182-00004	2.5	2.5	air	0.34	0.55	0.63	55							
	with grilles-between-the-glass	PEL-N-104-01183-00004				0.34	0.49	0.56	55							
11/16"	(HA) NaturalSun Low-E IG	PEL-N-104-01182-00002	3	3	air	0.34	0.54	0.62	55							
	with grilles-between-the-glass	PEL-N-104-01183-00002				0.34	0.49	0.55	55							
11/16"	(HA) NaturalSun Low-E IG	PEL-N-104-01188-00002	5	5	air	0.37	0.52	0.61	51							
	with grilles-between-the-glass	PEL-N-104-01189-00002				0.37	0.46	0.54	51							
11/16"	(HA) NaturalSun+ Low-E IG	PEL-N-104-01430-00001	2.5	2.5	air	0.28	0.50	0.61	43							
	with grilles-between-the-glass	PEL-N-104-01431-00001				0.28	0.45	0.55	43							
11/16"	(HA) NaturalSun+ Low-E IG	PEL-N-104-01434-00001	3	3	air	0.29	0.49	0.61	42							
	with grilles-between-the-glass	PEL-N-104-01435-00001				0.29	0.44	0.54	42							
11/16"	(HA) NaturalSun+ Low-E IG	PEL-N-104-01442-00001	5	5	air	0.32	0.47	0.59	38							
	with grilles-between-the-glass	PEL-N-104-01443-00001				0.33	0.42	0.53	38							

R-Value = 1/U-Factor
 SHGC = Solar Heat Gain Coefficient
 VLT % = Visible Light Transmission
 CR = Condensation Resistance
 ER = Canadian Energy Rating

(1) Glazing performance values are calculated based on NFRC 100, NFRC 200 and NFRC 500.

ENERGY STAR® values are updated to 2023 (version 7) criteria.

(2) The values shown are based on Canada's updated ENERGY STAR® 2020 initiative.

For center-glass values, see the Product Performance section.

Visit www.energystar.gov for Energy Star guidelines.

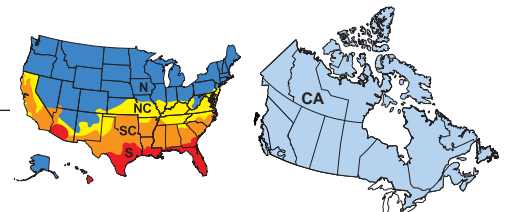



Glazing Thickness	Type of Glazing	NFRC Certified Product #	Glass (mm)		Gap Fill	Performance Values ¹				Shaded Areas Meet ENERGY STAR® Performance Criteria in Zones Shown						
			Ext.	Int.		U-Factor	SHGC	VLT	CR	U. S.		Canada ²				
										Zone		ER	Zone			
Fixed – High Altitude Glazing and Foam Insulation										N	NC	SC	S	CA		
11/16"	(HA) Advanced Low-E IG	PEL-N-104-00982-00004	2.5	2.5	air	0.30	0.30	0.55	57							
	with grilles-between-the-glass	PEL-N-104-00983-00004				0.30	0.27	0.49	57							
11/16"	(HA) Advanced Low-E IG	PEL-N-104-00982-00002	3	3	air	0.30	0.30	0.55	57							
	with grilles-between-the-glass	PEL-N-104-00983-00002				0.30	0.27	0.49	57							
11/16"	(HA) Advanced Low-E IG	PEL-N-104-00992-00002	5	5	air	0.33	0.30	0.54	52							
	with grilles-between-the-glass	PEL-N-104-00993-00002				0.34	0.27	0.48	52							
11/16"	(HA) SunDefense IG	PEL-N-104-01022-00004	2.5	2.5	air	0.29	0.22	0.51	57					S		
	with grilles-between-the-glass	PEL-N-104-01023-00004				0.29	0.20	0.46	57					S		
11/16"	(HA) SunDefense IG	PEL-N-104-01022-00002	3	3	air	0.29	0.22	0.51	57					S		
	with grilles-between-the-glass	PEL-N-104-01023-00002				0.29	0.20	0.45	57					S		
11/16"	(HA) SunDefense IG	PEL-N-104-01032-00002	5	5	air	0.33	0.23	0.50	52							
	with grilles-between-the-glass	PEL-N-104-01033-00002				0.34	0.21	0.44	52							
11/16"	(HA) SunDefense+ IG	PEL-N-104-01514-00001	2.5	2.5	air	0.25	0.22	0.50	45							
	with grilles-between-the-glass	PEL-N-104-01515-00001				0.25	0.20	0.45	45							
11/16"	(HA) SunDefense+ IG	PEL-N-104-01518-00001	3	3	air	0.25	0.22	0.50	44							
	with grilles-between-the-glass	PEL-N-104-01519-00001				0.25	0.20	0.44	44							
11/16"	(HA) SunDefense+ IG	PEL-N-104-01526-00001	5	5	air	0.28	0.22	0.49	39							
	with grilles-between-the-glass	PEL-N-104-01527-00001				0.29	0.20	0.43	39							
11/16"	(HA) AdvancedComfort Low-E IG	PEL-N-104-01062-00004	2.5	2.5	air	0.25	0.29	0.54	43		NC					
	with grilles-between-the-glass	PEL-N-104-01063-00004				0.25	0.26	0.48	43		NC					
11/16"	(HA) AdvancedComfort Low-E IG	PEL-N-104-01062-00002	3	3	air	0.25	0.29	0.54	43		NC					
	with grilles-between-the-glass	PEL-N-104-01063-00002				0.25	0.26	0.48	43		NC					
11/16"	(HA) AdvancedComfort Low-E IG	PEL-N-104-01068-00002	5	5	air	0.25	0.28	0.52	39		NC					
	with grilles-between-the-glass	PEL-N-104-01069-00002				0.25	0.26	0.47	39		NC					
11/16"	(HA) NaturalSun Low-E IG	PEL-N-104-00950-00004	2.5	2.5	air	0.31	0.55	0.63	56							
	with grilles-between-the-glass	PEL-N-104-00951-00004				0.31	0.49	0.56	56							
11/16"	(HA) NaturalSun Low-E IG	PEL-N-104-00950-00002	3	3	air	0.31	0.54	0.62	56							
	with grilles-between-the-glass	PEL-N-104-00951-00002				0.31	0.49	0.55	56							
11/16"	(HA) NaturalSun Low-E IG	PEL-N-104-00956-00002	5	5	air	0.34	0.52	0.61	51							
	with grilles-between-the-glass	PEL-N-104-00957-00002				0.34	0.46	0.54	51							
11/16"	(HA) NaturalSun+ Low-E IG	PEL-N-104-01542-00001	2.5	2.5	air	0.25	0.50	0.61	44	N					36	CA
	with grilles-between-the-glass	PEL-N-104-01543-00001				0.25	0.45	0.55	44	N					34	CA
11/16"	(HA) NaturalSun+ Low-E IG	PEL-N-104-01546-00001	3	3	air	0.26	0.49	0.61	43	N					35	CA
	with grilles-between-the-glass	PEL-N-104-01547-00001				0.26	0.44	0.54	43	N						
11/16"	(HA) NaturalSun+ Low-E IG	PEL-N-104-01554-00001	5	5	air	0.29	0.47	0.59	39							
	with grilles-between-the-glass	PEL-N-104-01555-00001				0.30	0.42	0.53	39							

R-Value = 1/U-Factor
 SHGC = Solar Heat Gain Coefficient
 VLT % = Visible Light Transmission
 CR = Condensation Resistance
 ER = Canadian Energy Rating

(1) Glazing performance values are calculated based on NFRC 100, NFRC 200 and NFRC 500. ENERGY STAR® values are updated to 2023 (version 7) criteria.
 (2) The values shown are based on Canada's updated ENERGY STAR® 2020 initiative. For center-glass values, see the Product Performance section. Visit www.energystar.gov for Energy Star guidelines.

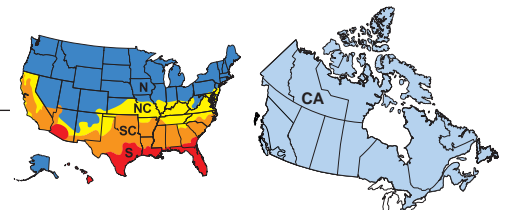



Glazing Thickness	Type of Glazing	NFRC Certified Product #	Glass (mm)		Gap Fill	Performance Values ¹				Shaded Areas Meet ENERGY STAR® Performance Criteria in Zones Shown				
			Ext.	Int.		U-Factor	SHGC	VLT	CR	U. S.		Canada ²		
										Zone	ER	Zone	ER	Zone
Fixed – 5 mm / 3 mm Glass										N	NC	SC	S	CA
1"	Clear IG	PEL-N-104-01144-00002	3	5	air	0.47	0.61	0.64	43					
	with grilles-between-the-glass	PEL-N-104-01145-00002				0.47	0.54	0.57	43					
1"	Advanced Low-E IG	PEL-N-104-01236-00002	3	5	argon	0.30	0.30	0.54	58					
	with grilles-between-the-glass	PEL-N-104-01237-00002				0.30	0.27	0.48	58					
1"	SunDefense™ IG	PEL-N-104-01276-00002	3	5	argon	0.29	0.22	0.50	58				S	
	with grilles-between-the-glass	PEL-N-104-01277-00002				0.29	0.20	0.45	58				S	
1"	SunDefense+ IG	PENDING	3	5	argon									
	with grilles-between-the-glass	PENDING												
1"	AdvancedComfort Low-E IG	PEL-N-104-01312-00002	3	5	argon	0.26	0.29	0.53	44					
	with grilles-between-the-glass	PEL-N-104-01313-00002				0.26	0.26	0.47	44					
1"	NaturalSun Low-E IG	PEL-N-104-01200-00002	3	5	argon	0.31	0.54	0.61	57					
	with grilles-between-the-glass	PEL-N-104-01201-00002				0.31	0.48	0.55	57					
1"	NaturalSun+ Low-E IG	PENDING	3	5	argon									
	with grilles-between-the-glass	PENDING												
Fixed – 5 mm / 3 mm Glass with Foam Insulation														
1"	Advanced Low-E IG	PEL-N-104-01004-00002	3	5	argon	0.27	0.30	0.54	58					
	with grilles-between-the-glass	PEL-N-104-01005-00002				0.27	0.27	0.48	58					
1"	SunDefense™ IG	PEL-N-104-01044-00002	3	5	argon	0.26	0.22	0.50	59			SC	S	
	with grilles-between-the-glass	PEL-N-104-01045-00002				0.26	0.20	0.45	59			SC	S	
1"	SunDefense+ IG	PENDING	3	5	argon									
	with grilles-between-the-glass	PENDING												
1"	AdvancedComfort Low-E IG	PEL-N-104-01080-00002	3	5	argon	0.23	0.29	0.53	45		NC			
	with grilles-between-the-glass	PEL-N-104-01081-00002				0.23	0.26	0.47	45		NC			
1"	NaturalSun Low-E IG	PEL-N-104-00968-00002	3	5	argon	0.28	0.54	0.61	58					35 CA
	with grilles-between-the-glass	PEL-N-104-00969-00002				0.28	0.48	0.55	58					
1"	NaturalSun+ Low-E IG	PENDING	3	5	argon									
	with grilles-between-the-glass	PENDING												
Fixed – 5 mm / 3 mm Glass High Altitude Glazing														
1"	(HA) Advanced Low-E IG	PEL-N-104-01216-00002	3	5	air	0.34	0.30	0.54	54					
	with grilles-between-the-glass	PEL-N-104-01217-00002				0.34	0.27	0.48	54					
1"	(HA) SunDefense IG	PEL-N-104-01256-00002	3	5	air	0.34	0.23	0.50	54					
	with grilles-between-the-glass	PEL-N-104-01257-00002				0.34	0.20	0.45	54					
1"	(HA) SunDefense+ IG	PENDING	3	5	air									
	with grilles-between-the-glass	PENDING												
1"	(HA) AdvancedComfort Low-E IG	PEL-N-104-01296-00002	3	5	air	0.29	0.29	0.53	41					
	with grilles-between-the-glass	PEL-N-104-01297-00002				0.29	0.26	0.47	41					
1"	(HA) NaturalSun Low-E IG	PEL-N-104-01184-00002	3	5	air	0.35	0.54	0.61	53					
	with grilles-between-the-glass	PEL-N-104-01185-00002				0.35	0.48	0.55	53					
1"	(HA) NaturalSun+ Low-E IG	PENDING	3	5	air									
	with grilles-between-the-glass	PENDING												
Fixed – 5 mm / 3 mm Glass High Altitude Glazing – with Foam Insulation														
1"	(HA) Advanced Low-E IG	PEL-N-104-00984-00002	3	5	air	0.31	0.30	0.54	54					
	with grilles-between-the-glass	PEL-N-104-00985-00002				0.31	0.27	0.48	54					
1"	(HA) SunDefense IG	PEL-N-104-01024-00002	3	5	air	0.31	0.23	0.50	55				S	
	with grilles-between-the-glass	PEL-N-104-01025-00002				0.31	0.20	0.45	55				S	
1"	(HA) SunDefense+ IG	PENDING	3	5	air									
	with grilles-between-the-glass	PENDING												
1"	(HA) AdvancedComfort Low-E IG	PEL-N-104-01064-00002	3	5	air	0.26	0.29	0.53	41					
	with grilles-between-the-glass	PEL-N-104-01065-00002				0.26	0.26	0.47	41					
1"	(HA) NaturalSun Low-E IG	PEL-N-104-00952-00002	3	5	air	0.32	0.54	0.61	54					
	with grilles-between-the-glass	PEL-N-104-00953-00002				0.32	0.48	0.55	54					
1"	(HA) NaturalSun+ Low-E IG	PENDING	3	5	air									
	with grilles-between-the-glass	PENDING												

(1) Glazing performance values are calculated based on NFRC 100, NFRC 200 and NFRC 500. ENERGY STAR® values are updated to 2023 (version 7) criteria.
 (2) The values shown are based on Canada's updated ENERGY STAR® 2020 initiative.

For center-glass values, see the Product Performance section.
 Visit www.energystar.gov for Energy Star guidelines.

R-Value = 1/U-Factor
 SHGC = Solar Heat Gain Coefficient
 VLT % = Visible Light Transmission
 CR = Condensation Resistance
 ER = Canadian Energy Rating



Glazing Thickness	Type of Glazing	NFRC Certified Product #	Glass (mm)		Gap Fill	Performance Values ¹				Shaded Areas Meet ENERGY STAR® Performance Criteria in Zones Shown									
			Ext.	Int.		U-Factor	SHGC	VLT	CR	U. S.		Canada ²							
										Zone		ER	Zone						
										N	NC	SC	S	CA					
Fixed – with Tinted Glazing																			
11/16"	Bronze Advanced Low-E IG	PEL-N-104-01350-00002	5	3	argon	0.29	0.26	0.35	59										
	with grilles-between-the-glass	PEL-N-104-01351-00002				0.29	0.24	0.31	59										
11/16"	Gray Advanced Low-E IG	PEL-N-104-01354-00002	5	3	argon	0.29	0.24	0.30	59										
	with grilles-between-the-glass	PEL-N-104-01355-00002				0.29	0.22	0.27	59				S						
11/16"	Green Advanced Low-E IG	PEL-N-104-01358-00002	5	3	argon	0.29	0.30	0.48	59										
	with grilles-between-the-glass	PEL-N-104-01359-00002				0.29	0.27	0.43	59										
Fixed – Tinted Glazing with Foam Insulation																			
11/16"	Bronze Advanced Low-E IG	PEL-N-104-01118-00002	5	3	argon	0.26	0.26	0.35	59										
	with grilles-between-the-glass	PEL-N-104-01119-00002				0.26	0.24	0.31	59										
11/16"	Gray Advanced Low-E IG	PEL-N-104-01122-00002	5	3	argon	0.26	0.24	0.30	59										
	with grilles-between-the-glass	PEL-N-104-01123-00002				0.26	0.22	0.27	59			SC	S						
11/16"	Green Advanced Low-E IG	PEL-N-104-01126-00002	5	3	argon	0.26	0.30	0.48	59										
	with grilles-between-the-glass	PEL-N-104-01127-00002				0.26	0.27	0.43	59										
Fixed – Tinted High Altitude Glazing																			
11/16"	Bronze Advanced Low-E IG	PEL-N-104-01326-00002	5	3	air	0.34	0.27	0.35	55										
	with grilles-between-the-glass	PEL-N-104-01327-00002				0.34	0.24	0.31	55										
11/16"	Gray Advanced Low-E IG	PEL-N-104-01330-00002	5	3	air	0.34	0.25	0.30	55										
	with grilles-between-the-glass	PEL-N-104-01331-00002				0.34	0.23	0.27	55										
11/16"	Green Advanced Low-E IG	PEL-N-104-01334-00002	5	3	air	0.34	0.30	0.48	55										
	with grilles-between-the-glass	PEL-N-104-01335-00002				0.34	0.27	0.43	55										
Fixed – Tinted High Altitude Glazing with Foam Insulation																			
11/16"	Bronze Advanced Low-E IG	PEL-N-104-01094-00002	5	3	air	0.31	0.27	0.35	55										
	with grilles-between-the-glass	PEL-N-104-01095-00002				0.31	0.24	0.31	55										
11/16"	Gray Advanced Low-E IG	PEL-N-104-01098-00002	5	3	air	0.31	0.25	0.30	55										
	with grilles-between-the-glass	PEL-N-104-01099-00002				0.31	0.23	0.27	55				S						
11/16"	Green Advanced Low-E IG	PEL-N-104-01102-00002	5	3	air	0.31	0.30	0.48	55										
	with grilles-between-the-glass	PEL-N-104-01103-00002				0.31	0.27	0.43	55										

R-Value = 1/U-Factor
 SHGC = Solar Heat Gain Coefficient
 VLT % = Visible Light Transmission
 CR = Condensation Resistance
 ER = Canadian Energy Rating

(1) Glazing performance values are calculated based on NFRC 100, NFRC 200 and NFRC 500.

ENERGY STAR® values are updated to 2023 (version 7) criteria.

(2) The values shown are based on Canada's updated ENERGY STAR® 2020 initiative.

For center-glass values, see the Product Performance section.

Visit www.energystar.gov for Energy Star guidelines.

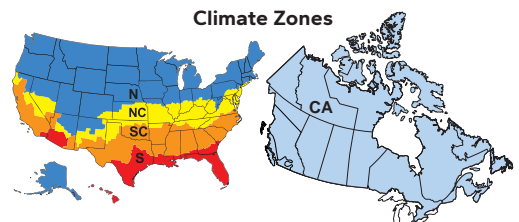



Glazing Thickness	Type of Glazing	NFRC Certified Product #	Glass (mm)		Gap Fill	Performance Values ¹				Shaded Areas Meet ENERGY STAR® Performance Criteria in Zones Shown					
			Ext.	Int.		U-Factor	SHGC	VLT	CR	U. S.		Canada ²			
										Zone	ER	Zone			
Fixed – Laminated Glazing											N	NC	SC	S	CA
11/16"	Advanced Low-E IG	PEL-N-104-01238-00002	4	7	argon	0.29	0.29	0.54	57						
	with grilles-between-the-glass	PEL-N-104-01239-00002				0.30	0.26	0.48	57						
11/16"	SunDefense™ IG	PEL-N-104-01278-00002	4	7	argon	0.29	0.22	0.50	57				S		
	with grilles-between-the-glass	PEL-N-104-01279-00002				0.30	0.20	0.44	57				S		
Fixed – Laminated Glazing with Foam Insulation															
11/16"	Advanced Low-E IG	PEL-N-104-01006-00002	4	7	argon	0.28	0.29	0.54	57						
	with grilles-between-the-glass	PEL-N-104-01007-00002				0.29	0.26	0.48	57						
11/16"	SunDefense™ IG	PEL-N-104-01046-00002	4	7	argon	0.28	0.22	0.50	58			SC	S		
	with grilles-between-the-glass	PEL-N-104-01047-00002				0.29	0.20	0.44	58				S		
Fixed – Laminated High Altitude Glazing															
11/16"	Advanced Low-E IG	PEL-N-104-01218-00002	4	7	air	0.34	0.30	0.54	52						
	with grilles-between-the-glass	PEL-N-104-01219-00002				0.35	0.27	0.48	52						
11/16"	SunDefense IG	PEL-N-104-01258-00002	4	7	air	0.34	0.22	0.50	53						
	with grilles-between-the-glass	PEL-N-104-01259-00002				0.35	0.20	0.44	53						
Fixed – Laminated High Altitude Glazing with Foam Insulation															
11/16"	Advanced Low-E IG	PEL-N-104-00986-00002	4	7	air	0.33	0.30	0.54	53						
	with grilles-between-the-glass	PEL-N-104-00987-00002				0.35	0.27	0.48	53						
11/16"	SunDefense IG	PEL-N-104-01026-00002	4	7	air	0.33	0.22	0.50	53						
	with grilles-between-the-glass	PEL-N-104-01027-00002				0.34	0.20	0.44	53						

R-Value = 1/U-Factor
 SHGC = Solar Heat Gain Coefficient
 VLT % = Visible Light Transmission
 CR = Condensation Resistance
 ER = Canadian Energy Rating

(1) Glazing performance values are calculated based on NFRC 100, NFRC 200 and NFRC 500.

ENERGY STAR® values are updated to 2023 (version 7) criteria.

(2) The values shown are based on Canada's updated ENERGY STAR® 2020 initiative.

For center-glass values, see the Product Performance section.

Visit www.energystar.gov for Energy Star guidelines.

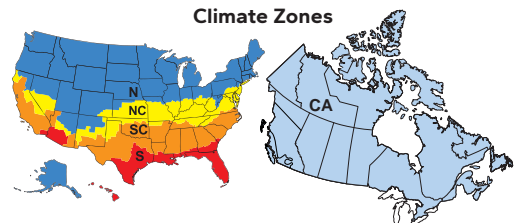



Grille Profiles

Grilles-Between-the-Glass

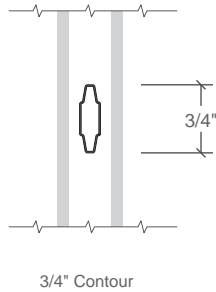

Grille Patterns

Prairie Lite Patterns

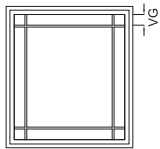

9-Lite Prairie

Standard corner lite dimension for Prairie patterns = 4" visible glass (VG).
Pattern availability may vary depending on size of unit.

Other Available Patterns

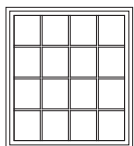

Traditional

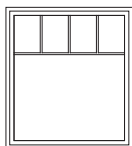

Top Row ⁽¹⁾

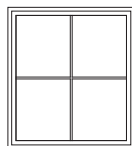

Special

Pattern availability may vary depending on size of unit.

(1) Standard visible glass to center line of separator bar = 14" or half of total visible glass height, whichever is smaller. Multiple rows are available up to 50% glass size.



Size Tables

Fixed Units

	(356) (343)	(457) (445)	(610) (597)	(711) (699)	(762) (749)	(813) (800)	(914) (902)	(1 067) (1 054)
Opening	1' 2"	1' 6"	2' 0"	2' 4"	2' 6"	2' 8"	3' 0"	3' 6"
Frame	1' 1 1/2"	1' 5 1/2"	1' 11 1/2"	2' 3 1/2"	2' 5 1/2"	2' 7 1/2"	2' 11 1/2"	3' 5 1/2"
(356) (343)	1-6/1-2	2-0/1-2	2-4/1-2	2-6/1-2	2-8/1-2	3-0/1-2	3-6/1-2	
(457) (446)	1-6/1-6	2-0/1-6	2-4/1-6	2-6/1-6	2-8/1-6	3-0/1-6	3-6/1-6	
(610) (597)	1-6/2-0	2-0/2-0	2-4/2-0	2-6/2-0	2-8/2-0	3-0/2-0	3-6/2-0	
(762) (749)						3-0/2-6	3-6/2-6	
(914) (902)	1-2/3-0					3-0/3-0	3-6/3-0	
(1 067) (1 054)	1-2/3-6					3-0/3-6	3-6/3-6	
(1 219) (1 207)	1-2/4-0					3-0/4-0	3-6/4-0	
(1 372) (1 359)	1-2/4-6					3-0/4-6	3-6/4-6	
(1 524) (1 511)	1-2/5-0					3-0/5-0	3-6/5-0	
(1 676) (1 664)						3-0/5-6	3-6/5-6	
(1 829) (1 816)						3-0/6-0	3-6/6-0	

Not to scale.

Special size units are available in 1/8" increments.



Size Tables

Fixed Units		(1 219) (1 207)	(1 372) (1 359)	(1 524) (1 511)	(1 829) (1 816)
Opening	Frame	4' 0"	4' 6"	5' 0"	6' 0"
	3' 11 1/2"	 4-0/1-2	 4-6/1-2	 5-0/1-2	 6-0/1-2
(356) (343)	1' 2"				
(457) (446)	1' 6"	 4-0/1-6	 4-6/1-6	 5-0/1-6	 6-0/1-6
(610) (597)	2' 0"	 4-0/2-0	 4-6/2-0	 5-0/2-0	 6-0/2-0
(762) (749)	2' 6"	 4-0/2-6	 4-6/2-6	 5-0/2-6	 6-0/2-6
(914) (902)	3' 0"	 4-0/3-0	 4-6/3-0	 5-0/3-0	 6-0/3-0
(1 067) (1 054)	3' 6"	 4-0/3-6	 4-6/3-6	 5-0/3-6	 6-0/3-6
(1 219) (1 207)	4' 0"	 4-0/4-0	 4-6/4-0	 5-0/4-0	 6-0/4-0
(1 372) (1 359)	4' 6"	 4-0/4-6	 4-6/4-6	 5-0/4-6	 6-0/4-6
(1 524) (1 511)	5' 0"	 4-0/5-0	 4-6/5-0	 5-0/5-0	 6-0/5-0
(1 676) (1 664)	5' 6"	 4-0/5-6	 4-6/5-6	 5-0/5-6	 6-0/5-6 (1)
(1 829) (1 816)	6' 0"	 4-0/6-0	 4-6/6-0	 5-0/6-0	 6-0/6-0 (1)

Not to scale.

Special size units are available in 1/8" increments.

(1) Tempered glass is not available.



Size Tables - Two-Wide Composites

Fixed Units

	(711) (699)	(914) (902)	(1 219) (1 207)	(1 422) (1 410)	(1 524) (1 511)	(1 626) (1 613)
Opening	2' 4"	3' 0"	4' 0"	4' 8"	5' 0"	5' 4"
Frame	2' 3 1/2"	2' 11 1/2"	3' 11 1/2"	4' 7 1/2"	4' 11 1/2"	5' 3 1/2"
(356) (343)						
(457) (446)						
(610) (597)						
(762) (749)						
(914) (902)						
(1 067) (1 054)						
(1 219) (1 207)						
(1 372) (1 359)						
(1 524) (1 511)						
(1 676) (1 664)						
(1 829) (1 816)						
6' 0"						
5' 11 1/2"						

Not to scale.

Special size units are available in 1/8" increments.

(1) Tempered glass is not available.



Size Tables - Two-Wide Composites

Fixed Units

	(1 829) (1 816)		(2 134) (2 121)		(2 438) (2 426)		(2 743) (2 731)	
	Opening 6' 0"		7' 0"		8' 0"		9' 0"	
	Frame 5' 11 1/2"		6' 11 1/2"		7' 11 1/2"		8' 11 1/2"	
(356) (343)	1' 2"	6-0/1-2	7-0/1-2	8-0/1-2	9-0/1-2			
(457) (446)	1' 6"	6-0/1-6	7-0/1-6	8-0/1-6	9-0/1-6			
(610) (597)	2' 0"	6-0/2-0	7-0/2-0	8-0/2-0	9-0/2-0			
(762) (749)	2' 6"	6-0/2-6	7-0/2-6	8-0/2-6	9-0/2-6			
(914) (902)	3' 0"	6-0/3-0	7-0/3-0	8-0/3-0	9-0/3-0			
(1 067) (1 054)	3' 6"	6-0/3-6	7-0/3-6	8-0/3-6	9-0/3-6			
(1 219) (1 207)	4' 0"	6-0/4-0	7-0/4-0	8-0/4-0	9-0/4-0			
(1 372) (1 359)	4' 6"	6-0/4-6	7-0/4-6	8-0/4-6	9-0/4-6			
(1 524) (1 511)	5' 0"	6-0/5-0	7-0/5-0	8-0/5-0	9-0/5-0			
(1 676) (1 664)	5' 6"	6-0/5-6	7-0/5-6	8-0/5-6	9-0/5-6			
(1 829) (1 816)	6' 0"	6-0/6-0	7-0/6-0	8-0/6-0	9-0/6-0			

Not to scale.

Special size units are available in 1/8" increments.

(1) Tempered glass is not available.



Size Tables - Three-Wide Composites

Fixed Units

	(1 067) (1 054)	(1 372) (1 359)	(1 829) (1 816)	(2 134) (2 121)	(2 286) (2 273)	(2 438) (2 426)	(2 743) (2 731)
Opening	3' 6"	4' 6"	6' 0"	7' 0"	7' 6"	8' 0"	9' 0"
Frame	3' 5 1/2"	4' 5 1/2"	5' 11 1/2"	6' 11 1/2"	7' 5 1/2"	7' 11 1/2"	8' 11 1/2"
(356) (343)		4-6/1-2	6-0/1-2	7-0/1-2	7-6/1-2	8-0/1-2	9-0/1-2
(457) (446)		4-6/1-6	6-0/1-6	7-0/1-6	7-6/1-6	8-0/1-6	9-0/1-6
(610) (597)		4-6/2-0	6-0/2-0	7-0/2-0	7-6/2-0	8-0/2-0	
(762) (749)							9-0/2-6
(914) (902)		3-6/3-0					9-0/3-0
(1 067) (1 054)		3-6/3-6					9-0/3-6
(1 219) (1 207)		3-6/4-0					9-0/4-0
(1 372) (1 359)		3-6/4-6					9-0/4-6
(1 524) (1 511)		3-6/5-0					9-0/5-0
(1 676) (1 664)							9-0/5-6
(1 829) (1 816)							9-0/6-0

Not to scale.

Special size units are available in 1/8" increments.

(1) Tempered glass is not available.

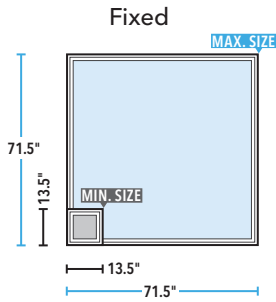

Composites

A composite is a window or door consisting of two or more sashes or panels within a single frame utilizing an integral mullion.

Single unit	2-Wide Composite with Integral Mullion	3-Wide Composite with Integral Mullion
<p>MINIMUM 1' 1-1/2" W x 1' 1-1/2" H (13-1/2" x 13-1/2") (343 x 343)</p> <p>MAXIMUM 5' 11-1/2" W x 5' 11-1/2" H (71-1/2" x 71-1/2") (1 816 x 1 816)</p>	<p>MINIMUM 2' 3-1/2" W x 1' 1-1/2" H (27-1/2" x 13-1/2") (698 x 343)</p> <p>MAXIMUM 8' 11-1/2" W x 5' 11-1/2" H (107-1/2" x 71-1/2") (2 743 x 1 816)</p>	<p>MINIMUM 3' 5-1/2" W x 1' 1-1/2" H (41-1/2" x 13-1/2") (1 067 x 343)</p> <p>MAXIMUM 8' 11-1/2" W x 5' 11-1/2" H (107-1/2" x 71-1/2") (2 743 x 1 816)</p>

General Notes:

- To convert areas to square meters (m²), multiply square feet by 0.0929.
- Rough Opening—Frame Dimension + 1/2".
- Keep frame dimensions to the nearest 1/8" increment
- Tempered glass must measure > 18-1/2" diagonally.

Miscellaneous Formulas

	Formula
Visible Glass	Width = Frame – 6-1/16" Height = Frame – 6-1/16"
Actual Glass	Width = Frame – 5-1/8" Height = Frame – 5-1/8"

(-) = Not Applicable

Keep frame dimensions to nearest 1/8" increments.

Composite units are not AAMA/WDMA performance certified. Pella Impervia composites are engineered to meet the performance class and grade shown in the Design Data tables.

Check Design Data tables to determine design pressure limitation of integral mullion for desired frame sizes. See the Installation and Performance sections at Pella.com for structural limitations.

When ordering and sizing composites, use overall frame / rough opening dimension.



Design Data

Single Rectangle Units

Call Out	Frame (Inches)		Visible Glass Ft ²	Standard Glass Thickness (mm)		Performance Class & Grade ₁
	Width	Height		Annealed	Tempered	
1-2/3-6	13-1/2	37-1/2	1.8	3	3	CW50
1-2/4-0	13-1/2	47-1/2	2.1	-	3	CW50
1-2/4-6	13-1/2	53-1/2	2.5	-	3	CW50
1-2/5-0	13-1/2	59-1/2	2.8	-	3	CW50
1-6/1-2	17-1/2	13-1/2	0.6	3	3	CW50
1-6/1-6	17-1/2	17-1/2	0.9	2.5	3	CW50
1-6/2-0	17-1/2	23-1/2	1.4	2.5	3	CW50
2-0/1-2	23-1/2	13-1/2	0.9	3	3	CW50
2-0/1-6	23-1/2	17-1/2	1.4	2.5	3	CW50
2-0/2-0	23-1/2	23-1/2	2.1	2.5	3	CW50
2-4/1-2	27-1/2	13-1/2	1.1	3	3	CW50
2-4/1-6	27-1/2	17-1/2	1.7	2.5	3	CW50
2-4/2-0	27-1/2	23-1/2	2.6	2.5	3	CW50
2-6/1-2	29-1/2	13-1/2	1.2	3	3	CW50
2-6/1-6	29-1/2	17-1/2	1.9	2.5	3	CW50
2-6/2-0	29-1/2	23-1/2	2.8	2.5	3	CW50
2-8/1-2	31-1/2	13-1/2	1.3	3	3	CW50
2-8/1-6	31-1/2	17-1/2	2.0	2.5	3	CW50
2-8/2-0	31-1/2	23-1/2	3.1	2.5	3	CW50
3-0/1-2	35-1/2	13-1/2	1.5	3	3	CW50
3-0/1-6	35-1/2	17-1/2	2.3	2.5	3	CW50
3-0/2-0	35-1/2	23-1/2	3.6	3	3	CW50
3-0/2-6	35-1/2	29-1/2	4.8	3	3	CW50
3-0/3-0	35-1/2	35-1/2	6.0	3	3	CW50
3-0/3-6	35-1/2	41-1/2	7.2	3	3	CW50
3-0/4-0	35-1/2	47-1/2	8.5	3	3	CW50
3-0/4-6	35-1/2	53-1/2	9.7	2.5	3	CW45
3-0/5-0	35-1/2	59-1/2	10.9	3	3	CW45
3-0/5-6	35-1/2	65-1/2	12.2	3	3	CW45
3-0/6-0	35-1/2	71-1/2	13.4	3	3	CW40
3-6/1-2	41-1/2	13-1/2	1.8	3	3	CW50
3-6/1-6	41-1/2	17-1/2	2.8	2.5	3	CW50
3-6/2-0	41-1/2	23-1/2	4.3	2.5	3	CW50
3-6/2-6	41-1/2	29-1/2	5.8	2.5	3	CW50
3-6/3-0	41-1/2	35-1/2	7.2	2.5	3	CW50
3-6/3-6	41-1/2	41-1/2	8.7	2.5	3	CW45
3-6/4-0	41-1/2	47-1/2	10.2	3	3	CW45
3-6/4-6	41-1/2	53-1/2	11.7	3	3	CW40
3-6/5-0	41-1/2	59-1/2	13.2	3	3	CW40
3-6/5-6	41-1/2	65-1/2	14.6	3	3	CW40
3-6/6-0	41-1/2	71-1/2	16.1	3	3	CW40

Single Rectangle Units

Call Out	Frame (Inches)		Visible Glass Ft ²	Standard Glass Thickness (mm)		Performance Class & Grade ₁
	Width	Height		Annealed	Tempered	
4-0/1-6	47-1/2	17-1/2	3.3	2.5	3	CW50
4-0/2-0	47-1/2	23-1/2	5.0	2.5	3	CW50
4-0/2-6	47-1/2	29-1/2	6.7	2.5	3	CW50
4-0/3-0	47-1/2	35-1/2	8.5	2.5	3	CW50
4-0/3-6	47-1/2	41-1/2	10.2	3	5	CW45
4-0/4-0	47-1/2	47-1/2	11.9	3	5	CW40
4-0/4-6	47-1/2	53-1/2	13.7	3	5	CW40
4-0/5-0	47-1/2	59-1/2	15.4	3	5	CW40
4-0/5-6	47-1/2	65-1/2	17.1	3	5	CW35
4-0/6-0	47-1/2	71-1/2	18.8	5	5	CW35
4-6/1-2	53-1/2	13-1/2	2.5	-	3	CW50
4-6/1-6	53-1/2	17-1/2	3.8	2.5	3	CW50
4-6/2-0	53-1/2	23-1/2	5.7	2.5	3	CW50
4-6/2-6	53-1/2	29-1/2	7.7	2.5	3	CW50
4-6/3-0	53-1/2	35-1/2	9.7	2.5	3	CW45
4-6/3-6	53-1/2	41-1/2	11.7	3	5	CW40
4-6/4-0	53-1/2	47-1/2	13.7	3	5	CW40
4-6/4-6	53-1/2	53-1/2	15.6	3	5	CW35
4-6/5-0	53-1/2	59-1/2	17.6	5	5	CW35
4-6/5-6	53-1/2	65-1/2	19.6	5	5	CW35
4-6/6-0	53-1/2	71-1/2	21.6	5	5	CW35
5-0/1-2	59-1/2	13-1/2	2.8	-	3	CW50
5-0/1-6	59-1/2	17-1/2	4.2	2.5	3	CW50
5-0/2-0	59-1/2	23-1/2	6.5	2.5	3	CW45/CW50
5-0/2-6	59-1/2	29-1/2	8.7	2.5	3	CW45/CW50
5-0/3-0	59-1/2	35-1/2	10.9	3	3	CW45
5-0/3-6	59-1/2	41-1/2	13.2	3	5	CW40
5-0/4-0	59-1/2	47-1/2	15.4	3	5	CW40
5-0/4-6	59-1/2	53-1/2	17.6	5	5	CW35
5-0/5-0	59-1/2	59-1/2	19.8	5	5	CW35
5-0/5-6	59-1/2	65-1/2	22.1	5	5	CW30
5-0/6-0	59-1/2	71-1/2	24.3	5	5	CW30
6-0/1-2	71-1/2	13-1/2	3.4	-	3	CW50
6-0/1-6	71-1/2	17-1/2	5.2	-	3	CW50
6-0/2-0	71-1/2	23-1/2	7.9	2.5	3	CW35/CW50
6-0/2-6	71-1/2	29-1/2	10.7	3	3	CW45/CW50
6-0/3-0	71-1/2	35-1/2	13.4	3	3	CW45
6-0/3-6	71-1/2	41-1/2	16.1	3	5	CW40
6-0/4-0	71-1/2	47-1/2	18.8	5	5	CW35
6-0/4-6	71-1/2	53-1/2	21.6	5	5	CW35
6-0/5-0	71-1/2	59-1/2	24.3	5	5	CW30
6-0/5-6	71-1/2	65-1/2	27.0	5	-	CW30
6-0/6-0	71-1/2	71-1/2	29.7	5	-	CW30

(1) Maximum performance when glazed with the appropriate glass thickness. Second value, where shown, requires tempered glass.

To convert areas to square meters (m²), multiply square feet by 0.0929.



Design Data

Two-Wide Fixed Window Composite

Call Out	Frame (Inches)		Visible Glass Ft ²	Standard Glass Thickness (mm)		Performance Class & Grade ¹
	Width	Height		Annealed	Tempered	
2-4/3-0	27-1/2	35-1/2	3.0	2.5	3	LC30
2-4/3-6	27-1/2	37-1/2	3.7	2.5	3	LC30
2-4/4-0	27-1/2	47-1/2	4.3	3	3	LC30
2-4/4-6	27-1/2	53-1/2	4.9	3	3	LC30
2-4/5-0	27-1/2	59-1/2	5.5	3	3	LC30
3-0/1-2	34-1/2	13-1/2	1.2	2.5	3	LC30
3-0/1-6	34-1/2	17-1/2	1.8	2.5	3	LC30
3-0/2-0	34-1/2	23-1/2	2.8	2.5	3	LC30
4-0/1-2	47-1/2	13-1/2	1.8	2.5	3	LC30
4-0/1-6	47-1/2	17-1/2	2.8	2.5	3	LC30
4-0/2-0	47-1/2	23-1/2	4.2	2.5	3	LC30
4-8/1-2	55-1/2	13-1/2	2.2	2.5	3	LC30
4-8/1-6	55-1/2	17-1/2	3.4	2.5	3	LC30
4-8/2-0	55-1/2	23-1/2	5.2	2.5	3	LC30
5-0/1-2	59-1/2	13-1/2	2.4	2.5	3	LC30
5-0/1-6	59-1/2	17-1/2	3.7	2.5	3	LC30
5-0/2-0	59-1/2	23-1/2	5.7	2.5	3	LC30
5-4/1-2	63-1/2	13-1/2	2.6	2.5	3	LC30
5-4/1-6	63-1/2	17-1/2	4.0	2.5	3	LC30
5-4/2-0	63-1/2	23-1/2	6.2	2.5	3	LC30
6-0/1-2	71-1/2	13-1/2	3.0	2.5	3	LC30
6-0/1-6	71-1/2	17-1/2	4.7	2.5	3	LC30
6-0/2-0	71-1/2	23-1/2	7.1	2.5	3	LC30
6-0/2-6	71-1/2	31-1/2	9.6	2.5	3	LC30
6-0/3-0	71-1/2	35-1/2	12.0	2.5	3	LC30
6-0/3-6	71-1/2	41-1/2	14.5	2.5	3	LC30
6-0/4-0	71-1/2	47-1/2	16.9	2.5	3	LC30
6-0/4-6	71-1/2	53-1/2	19.4	2.5	3	LC30
6-0/5-0	71-1/2	59-1/2	21.8	3	3	LC30
6-0/5-6	71-1/2	65-1/2	24.3	3	3	LC30
6-0/6-0	71-1/2	71-1/2	26.8	3	3	LC30
7-0/1-2	83-1/2	13-1/2	3.7	2.5	3	LC30
7-0/1-6	83-1/2	17-1/2	5.6	2.5	3	LC30
7-0/2-0	83-1/2	23-1/2	8.6	2.5	3	LC30
7-0/2-6	83-1/2	31-1/2	11.5	2.5	3	LC30
7-0/3-0	83-1/2	35-1/2	14.5	2.5	3	LC30
7-0/3-6	83-1/2	41-1/2	17.4	3	3	LC30
7-0/4-0	83-1/2	47-1/2	20.4	3	3	LC30
7-0/4-6	83-1/2	53-1/2	23.3	3	3	LC30
7-0/5-0	83-1/2	59-1/2	26.3	3	3	LC30
7-0/5-6	83-1/2	65-1/2	29.3	3	3	LC30
7-0/6-0	83-1/2	71-1/2	32.2	3	3	LC25

Two-Wide Fixed Window Composite

Call Out	Frame (Inches)		Visible Glass Ft ²	Standard Glass Thickness (mm)		Performance Class & Grade ¹
	Width	Height		Annealed	Tempered	
8-0/1-2	95-1/2	13-1/2	4.3	3	3	LC30
8-0/1-6	95-1/2	17-1/2	6.6	2.5	3	LC30
8-0/2-0	95-1/2	23-1/2	10.0	2.5	3	LC30
8-0/2-6	95-1/2	31-1/2	13.5	2.5	3	LC30
8-0/3-0	95-1/2	35-1/2	16.9	2.5	3	LC30
8-0/3-6	95-1/2	41-1/2	20.4	3	3	LC30
8-0/4-0	95-1/2	47-1/2	23.8	3	3	LC30
8-0/4-6	95-1/2	53-1/2	27.3	3	3	LC30
8-0/5-0	95-1/2	59-1/2	30.8	3	3	LC30
8-0/5-6	95-1/2	65-1/2	34.2	3	3	R25
8-0/6-0	95-1/2	71-1/2	37.7	5	5	R20
9-0/1-2	107-1/2	13-1/2	4.9	3	3	LC30
9-0/1-6	107-1/2	17-1/2	7.5	2.5	3	LC30
9-0/2-0	107-1/2	23-1/2	11.5	2.5	3	LC30
9-0/2-6	107-1/2	31-1/2	15.4	2.5	3	LC30
9-0/3-0	107-1/2	35-1/2	19.4	2.5	3	LC30
9-0/3-6	107-1/2	41-1/2	23.3	3	3	LC30
9-0/4-0	107-1/2	47-1/2	27.3	3	3	LC30
9-0/4-6	107-1/2	53-1/2	31.3	3	3	LC30
9-0/5-0	107-1/2	59-1/2	35.2	5	5	LC30
9-0/5-6	107-1/2	65-1/2	39.2	5	5	R25
9-0/6-0	107-1/2	71-1/2	43.1	5	5	R20

(1) Maximum performance when glazed with the appropriate glass thickness.

Composite units are not AAMA/WDMA performance certified. Pella Impervia composites are engineered to meet the performance class and grade shown.

To convert areas to square meters (m²), multiply square feet by 0.0929.



Design Data

Three-Wide Fixed Window Composite						
Call Out	Frame (Inches)		Visible Glass Ft ²	Standard Glass Thickness (mm)		Performance Class & Grade ¹
	Width	Height		Annealed	Tempered	
3-6/3-0	41-1/2	35-1/2	4.6	2.5	3	LC30
3-6/3-6	41-1/2	37-1/2	5.5	2.5	3	LC30
3-6/4-0	41-1/2	47-1/2	6.4	3	3	LC30
3-6/4-6	41-1/2	53-1/2	7.4	3	3	LC30
3-6/5-0	41-1/2	59-1/2	8.3	3	3	LC30
4-6/1-2	53-1/2	13-1/2	1.8	2.5	3	LC30
4-6/1-6	53-1/2	17-1/2	2.7	2.5	3	LC30
4-6/2-0	53-1/2	23-1/2	4.2	2.5	3	LC30
6-0/1-2	71-1/2	13-1/2	2.7	2.5	3	LC30
6-0/1-6	71-1/2	17-1/2	4.2	2.5	3	LC30
6-0/2-0	71-1/2	23-1/2	6.3	2.5	3	LC30
7-0/1-2	83-1/2	13-1/2	3.3	2.5	3	LC30
7-0/1-6	83-1/2	17-1/2	5.1	2.5	3	LC30
7-0/2-0	83-1/2	23-1/2	7.8	2.5	3	LC30
7-6/1-2	89-1/2	13-1/2	3.6	2.5	3	LC30
7-6/1-6	89-1/2	17-1/2	5.6	2.5	3	LC30
7-6/2-0	89-1/2	23-1/2	8.5	2.5	3	LC30
8-0/1-2	95-1/2	13-1/2	3.9	2.5	3	LC30
8-0/1-6	95-1/2	17-1/2	6.1	2.5	3	LC30
8-0/2-0	95-1/2	23-1/2	9.2	2.5	3	LC30
9-0/1-2	107-1/2	13-1/2	4.6	2.5	3	LC30
9-0/1-6	107-1/2	17-1/2	7.0	2.5	3	LC30
9-0/2-0	107-1/2	23-1/2	10.7	2.5	3	LC30
9-0/2-6	107-1/2	31-1/2	14.4	2.5	3	LC30
9-0/3-0	107-1/2	35-1/2	18.1	2.5	3	LC30
9-0/3-6	107-1/2	41-1/2	21.7	2.5	3	LC30
9-0/4-0	107-1/2	47-1/2	25.4	2.5	3	LC30
9-0/4-6	107-1/2	53-1/2	29.1	2.5	3	LC30
9-0/5-0	107-1/2	59-1/2	32.8	3	3	LC30
9-0/5-6	107-1/2	65-1/2	36.5	3	3	LC30
9-0/6-0	107-1/2	71-1/2	40.1	3	3	LC30

(1) Maximum performance when glazed with the appropriate glass thickness.

Composite units are not AAMA/WDMA performance certified. Pella Impervia composites are engineered to meet the performance class and grade shown.

To convert areas to square meters (m²), multiply square feet by 0.0929.



Detailed Product Description

Frame

- Frame is Duracast® fiberglass composite — five-layer pultruded fiberglass material [with optional foam insulation¹] reinforced with a Pella patented interlocking mat.
- Overall frame depth is 3".
- Nominal wall thickness of Duracast fiberglass composite members is .050" to .070" thick.
- Frame corners are mitered, joined and bonded with corner lock and mechanically fastened with injected polyurethane adhesive.
- Sill is fitted with weep valve assemblies.
- Jamb contains factory drilled (counter-bored) installation screw holes. Block Frame and Flush Flange only.
- Optional factory-applied jamb extensions available in 4-9/16" and 6-9/16".

Sash

- Sash is Duracast fiberglass composite — five-layer pultruded fiberglass material [with optional foam insulation¹] reinforced with a Pella patented interlocking mat.
- All sash members have mitered corners bonded with corner lock and sealed with injected polyurethane adhesive.

Exterior / Interior

- Duracast fiberglass composite surfaces with powder-coat paint finish.
 - Color is [White] [Brown] [Black] [Tan] [Morning Sky Gray].
 - or -
 - Dual-color option [Brown] [Black] [Tan] [Morning Sky Gray] exterior with White interior².

Glazing System

- Quality float glass complying with ASTM C 1036.
- 1" insulating glass [[annealed] [tempered]] [obscure³] [[clear] [Advanced] [SunDefense™] [SunDefense+] [AdvancedComfort] [NaturalSun] [NaturalSun+] Low-E coated, with argon]] sealed and bonded to frame.
- High altitude glazing available.
- Open glazing available for PTAC applications – frame only no sash.

Optional Products

Grilles

- Grilles-Between-the-Glass
 - Insulating glass contains 3/4" contoured aluminum grille bars permanently installed between two panes of glass.
 - Grilles are factory prefinished [White] [Brown] [Black] [Tan] [Morning Sky Gray] to match interior and exterior finish.

Foam Insulation Inserts:

Fixed Window

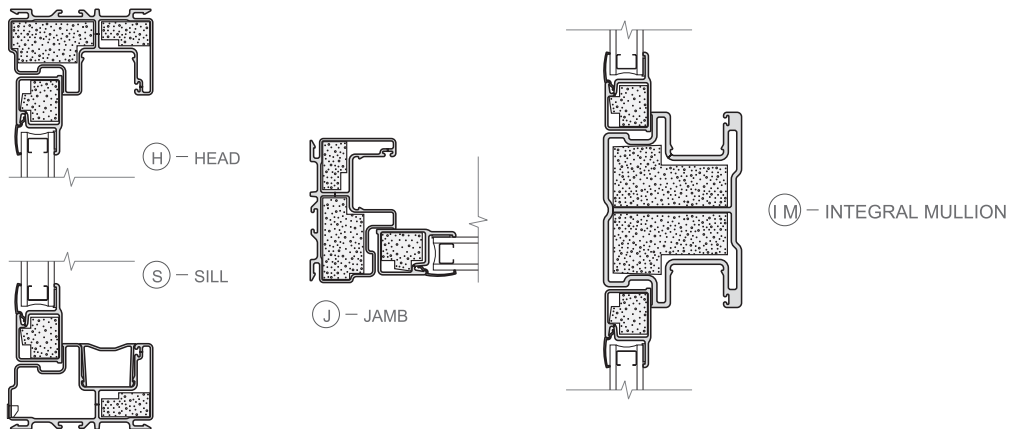

(1) Foam insulation inserts are not available with clear glazing.
 (2) Dual-color finish is not available on products with integral nailing fin.
 (3) Obscure glazing is not available when AdvancedComfort Low-E coated IG is specified.



Frame Types

STANDARD
BLOCK FRAME

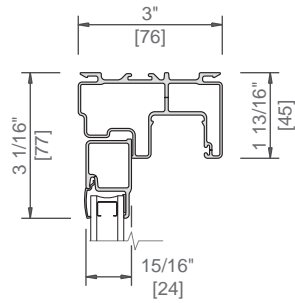

INTEGRAL NAILING FIN

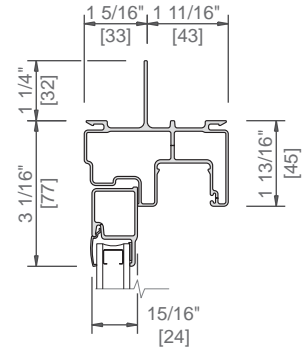

BLOCK FRAME
STANDARD FIN

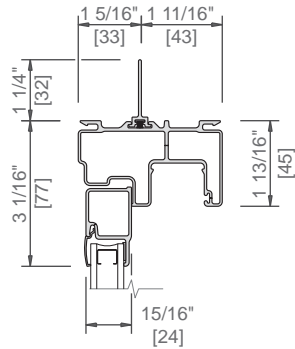

FLUSH FLANGE

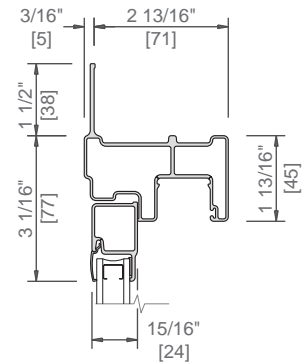

BLOCK FRAME
OFFSET FIN

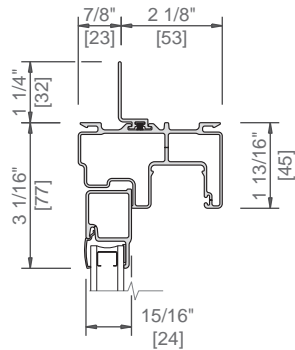

Scale 3" = 1' 0"

All dimensions are approximate.

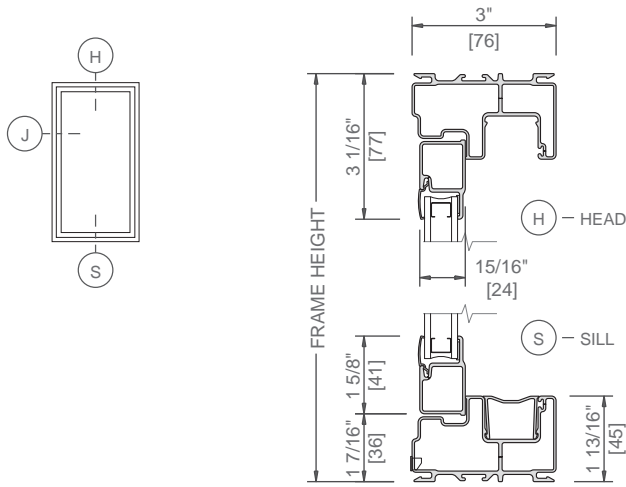

BLOCK FRAME

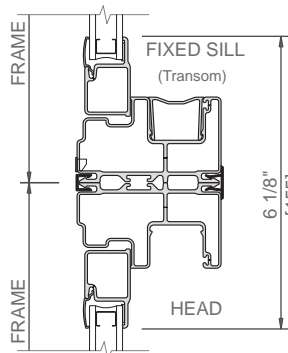
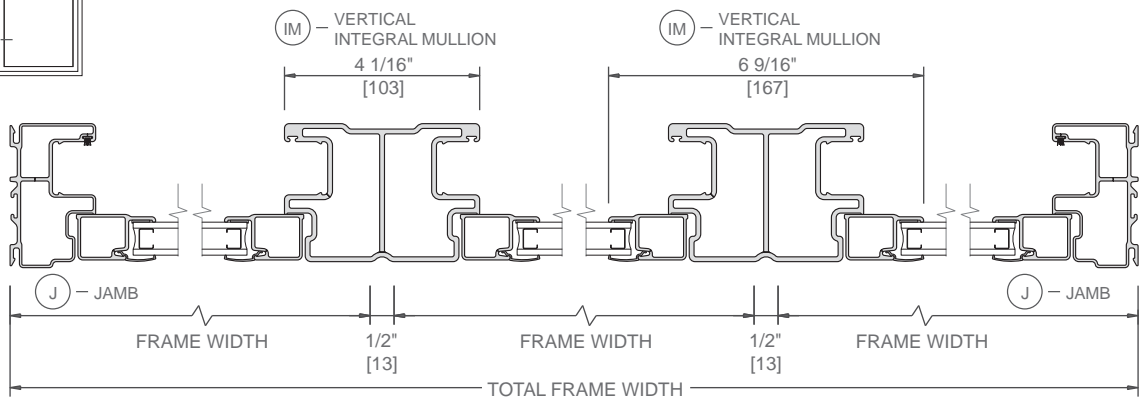
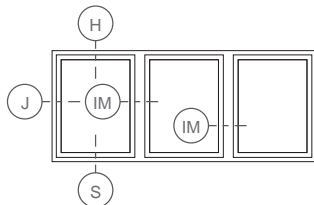
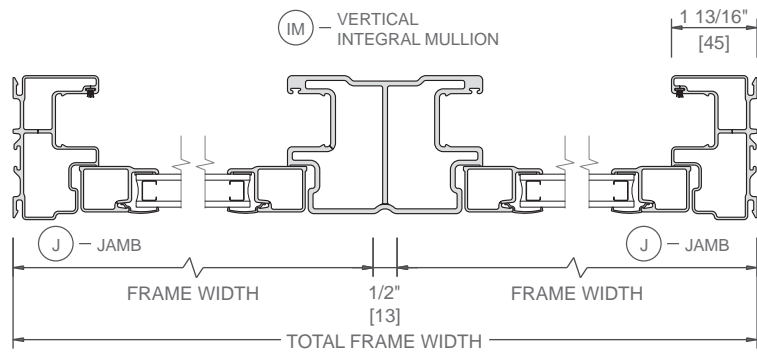
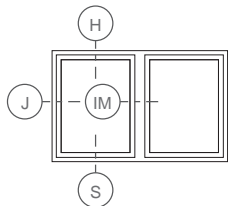
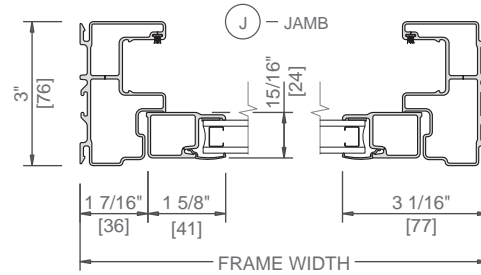

COMBINATION JOINING MULLION (Horizontal or Vertical, Horizontal Shown)

Scale 3" = 1' 0"

All dimensions are approximate.

See Composite and Combination section for mullion applications and structural limitations.



Unit Sections

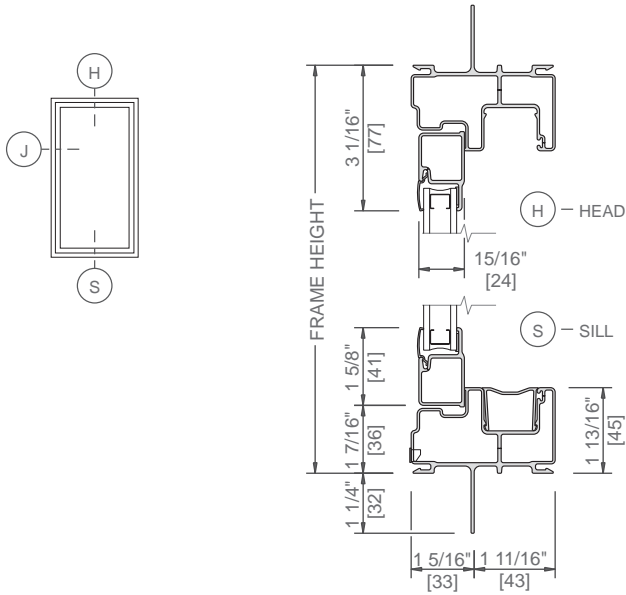

INTEGRAL NAILING FIN

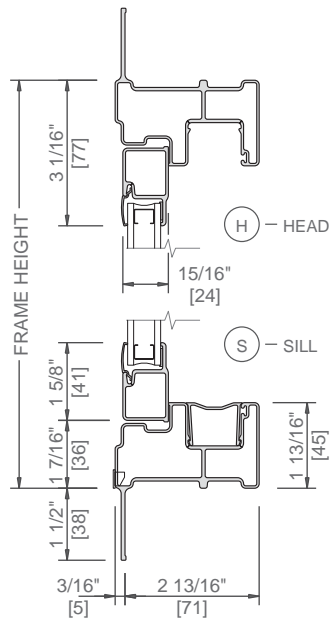
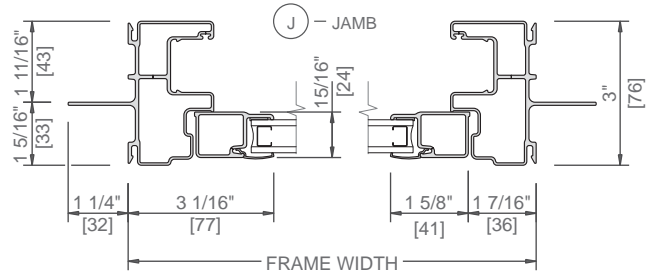

FLUSH FLANGE

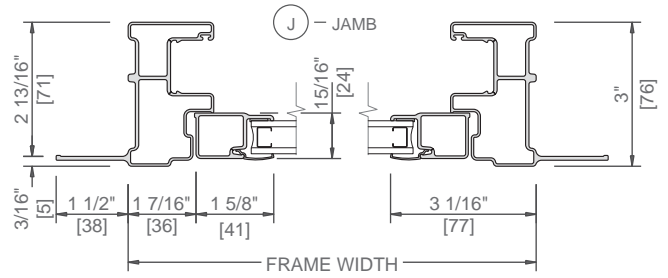

Scale 3" = 1' 0"

All dimensions are approximate.