



Product Selection Guide

Size and Performance Data .....DH-2

Sound Transmission Class .....DH-2

Features and Options ..... DH-3

Glazing Performance

    3/4" Dual-Pane Glazing ..... DH-4

    1" Triple-Pane Glazing ..... DH-5

    3/4" Dual-Pane Glazing with Structural Reinforcement..... DH-6

Grille Types .....DH-7

Size Tables ..... DH-8

Special Sizes, Dimensions and Formulas..... DH-13

Design Data

    Equal Sash .....DH-14

    Cottage Sash..... DH-19

    Contemporary Sash ..... DH-24

Detailed Product Descriptions ..... DH-29

Unit Sections

    Optional Foam Insulation..... DH-30

    Frame Types .....DH-31

    Standard Nail Fin ..... DH-32

    Integral Mullion ..... DH-33

    Block Frame..... DH-34

    Nail Fin with Flat Casing ..... DH-35

**Document Navigation Tips:**

Items listed in the table of contents above are active links that will take you to the corresponding page. The company logo on each page is a link back to this table of contents. Bookmarks are also included in this PDF document and are available as an additional navigation option.

**Supporting documents for this product:**

Test Reports:

[https://media.pella.com/professional/adm/CertificationReports/Test\\_Reports\\_Vinyl-250.pdf?utm\\_source=pdfdoc](https://media.pella.com/professional/adm/CertificationReports/Test_Reports_Vinyl-250.pdf?utm_source=pdfdoc)

CSI Specs (readable using Microsoft Word or other text editing application):

[https://media.pella.com/professional/adm/Vinyl250-CSI\\_Specs/08\\_53\\_13\\_DH-250.rtf?utm\\_source=pdfdoc](https://media.pella.com/professional/adm/Vinyl250-CSI_Specs/08_53_13_DH-250.rtf?utm_source=pdfdoc)

Detailed Product Description (readable using Microsoft Word or other text editing application):

[https://media.pella.com/professional/adm/Vinyl250/V\\_250DH\\_DPD.rtf?utm\\_source=pdfdoc](https://media.pella.com/professional/adm/Vinyl250/V_250DH_DPD.rtf?utm_source=pdfdoc)

Size Tables (requires appropriate CAD software to read and use):

[https://media.pella.com/professional/adm/Vinyl250/V250-DH-Elev\\_D.dwg?utm\\_source=pdfdoc](https://media.pella.com/professional/adm/Vinyl250/V250-DH-Elev_D.dwg?utm_source=pdfdoc)

CAD cross sections (requires appropriate CAD software to read and use):

[https://media.pella.com/professional/adm/Vinyl250/V250-DH-Details\\_D.dwg?utm\\_source=pdfdoc](https://media.pella.com/professional/adm/Vinyl250/V250-DH-Details_D.dwg?utm_source=pdfdoc)

3D & BIM (requires appropriate software to read and use):

[https://media.pella.com/professional/adm/RevitFiles/250-Revit/Window-Double\\_Hung-Pella-250.zip?utm\\_source=pdfdoc](https://media.pella.com/professional/adm/RevitFiles/250-Revit/Window-Double_Hung-Pella-250.zip?utm_source=pdfdoc)

Sketchup (requires appropriate software to read and use):

[https://media.pella.com/professional/adm/Vinyl250/PellaSKP\\_250Series\\_Double-Hung.zip?utm\\_source=pdfdoc](https://media.pella.com/professional/adm/Vinyl250/PellaSKP_250Series_Double-Hung.zip?utm_source=pdfdoc)

Combination Recommendations:

[https://media.pella.com/professional/adm/Vinyl250/V250\\_Combo.pdf?utm\\_source=pdfdoc](https://media.pella.com/professional/adm/Vinyl250/V250_Combo.pdf?utm_source=pdfdoc)

Installation Details:

[https://media.pella.com/professional/adm/Vinyl250/V250-InstallDetails.pdf?utm\\_source=pdfdoc](https://media.pella.com/professional/adm/Vinyl250/V250-InstallDetails.pdf?utm_source=pdfdoc)

Microsoft and Microsoft Word are registered trademarks of Microsoft Corp.

The information published in this document is believed to be accurate at the time of publication. However, because we are constantly working to improve our products, specifications are subject to change without notice. Consult your local sales representative for up-to-date product information.



# 250 Series Double-Hung

## Performance Data

Sizes	
Standard Sizes	S
Special Sizes Available Built on 1/8" Increments	O
Frames	
Nail Fin Only	O
Nail Fin with J-Channel	O
Nail Fin with Flat Casing (Northeast region only)	O
3-1/4" Block	S
Double Wall Flush Flange (West Region Only)	O
Integral 5/8" Flange	O
Performance <sub>1</sub>	
Standard Performance	
Meets or Exceeds AAMA/WDMA Ratings	R-PG20 – R-PG35 AAMA Certified
Air Infiltration (cfm/ft <sup>2</sup> of frame @ 1.57 psf wind pressure) <sub>2</sub>	0.10
Design Pressure	20 – 35 psf
Water Penetration Resistance	3.14 – 5.43 psf
Performance Upgrade <sub>3</sub>	
Meets or Exceeds AAMA/WDMA Ratings	R-PG50 AAMA Certified
Air Infiltration (cfm/ft <sup>2</sup> of frame @ 1.57 psf wind pressure) <sub>2</sub>	0.10
Design Pressure	50 psf
Water Penetration Resistance	7.52 psf
Standard Performance	
Meets or Exceeds AAMA/WDMA Ratings	R-PG20 – R-PG35 AAMA Certified
Air Infiltration (cfm/ft <sup>2</sup> of frame @ 1.57 psf wind pressure) <sub>2</sub>	0.10
Design Pressure	20 – 35 psf
Water Penetration Resistance	3.14 – 5.43 psf
Nail Fin with Flat Casing (Northeast Region Only)	
Meets or Exceeds AAMA/WDMA Ratings	R-PG15 – R-PG35 AAMA Certified
Air Infiltration (cfm/ft <sup>2</sup> of frame @ 1.57 psf wind pressure) <sub>2</sub>	0.13
Design Pressure	15 psf
Water Penetration Resistance	5.43 psf
Other Performance Criteria	
Forced Entry Resistance (Minimum Security Grade) <sub>4</sub>	40
Operating Force (lb) Initiate Motion / Maintain Motion (of AAMA tested size and glazing) <sub>5</sub>	35

### Sound Transmission Class and Outdoor-Indoor Transmission Class

Frame Size Tested <sub>6</sub>	Glazing System				STC Rating	OITC Rating
	Overall Glazing Thickness	Exterior Glass Thickness	Interior Glass Thickness	Third Pane Thickness		
<b>Double-Hung – Dual-Pane Insulating Glass</b>						
48" x 60"	11/16"	2.5mm	2.5mm	—	26	22
<b>Double-Hung – Triple-Pane Insulating Glass</b>						
48" x 60"	1"	3mm	3mm	3mm	28	24

S = Standard; O = Optional;

(1) Published performance data is for single unit only. See Design Data pages in this section for specific product performance class and grade values.

(2) Published performance data for air infiltration is determined by testing a minimum of four (4) products of NFRC model size. Testing is conducted in accordance with ASTM E283. Air infiltration ratings for products will differ by size. The performance data does not apply to combination assemblies unless noted. Actual product performance may vary for a number of reasons including installation and product care.

(3) The sash members may have metal reinforcement in the cavities of the extrusion to achieve the stated Performance Grade. The exterior appearance of the unit is unchanged.

(4) The higher the level, the greater the product's ability to resist forced entry.

(5) Glazing configurations may result in higher operational forces.

(6) ASTM E 1425 defines standard sizes for acoustical testing. Ratings achieved at that size are representative of all sizes of the same configuration. The presence of low-e or argon have negligible effect on sound attenuation characteristics.



## 250 Series Double-Hung

### Features and Options

	Double-Hung
<b>Glazing (Insulating Glass)</b>	
<b>Glazing Type</b>	
Dual-pane insulating glass	S
Triple-pane insulating glass	O
<b>Insulated Glass Options / Low-E Types</b>	
Advanced Low-E	S
NaturalSun Low-E	O
NaturalSun+ Low-E <sub>1</sub>	O
SunDefense Low-E <sub>1</sub>	O
SunDefense+ Low-E <sub>1</sub>	O
<b>Additional Glazing Options</b>	
Annealed glass	S
Tempered glass	O
Bronze-tinted Advanced Low-E <sub>1</sub>	O
Obscure glass <sub>2</sub>	O
<b>Gas Fill / High Altitude</b>	
Argon	O
High altitude	O
High altitude with argon <sub>1</sub>	O
<b>Sash</b>	
Foam insulation	O
Performance upgrade	O
<b>Interior / Exterior Color</b>	
White Interior/White Exterior	S
Almond Interior/Almond Exterior	O
Fossil Interior/Fossil Exterior	O
White Interior/Brown Exterior <sub>3</sub>	O
White Interior/Black Exterior <sub>3</sub>	O

	Double-Hung
<b>Hardware</b>	
Color matched hardware	S
<b>Sash Locks</b>	
Standard Cam Lock	S
Autolock	O
<b>Tilt-Wash Cleaning</b>	
Tilt to interior on both sashes	S
<b>Screens</b>	
InView™ flat screen	S
Hidden Screen	O
<b>Grilles</b>	
<b>Grilles-Between-the-Glass<sub>3</sub></b>	
3/4" Contour	O
5/8" flat	O
Grille Patterns: Traditional, Prairie, Top Row, Custom - Equally Divided	O

S = Standard; O = Optional

(1) Not available with triple-pane glazing.

(2) Contact your local sales representative for current offering.

(3) Not available at launch for Nail Fin with flat casing option, contact your local sales representative for current offering.



# 250 Series Double-Hung

## Glazing Performance - Total Unit

Glazing Thickness	Type of Glazing	NFRC Certified Product #	Glass (mm)		Gap Fill	Performance Values <sup>1</sup>				Shaded Areas Meet ENERGY STAR® Performance Criteria in Zones Shown					
			Ext.	Int.		U-Factor	SHGC	VLT	CR	U. S.		Canada <sup>2</sup>			
										Zone	ER	Zone	ER	Zone	
<b>Vent — Dual-Pane</b>											N	NC	SC	S	CA
3/4"	Advanced Low-E IG	PEL-A-290-00152-00003	3	3	air	0.33	0.28	0.53	54						
	with SDL or grilles-between-the-glass	PEL-A-290-00152-00004				0.33	0.25	0.47	54						
3/4"	Advanced Low-E IG	PEL-A-290-00155-00003	3	3	argon	0.29	0.28	0.53	58						
	with SDL or grilles-between-the-glass	PEL-A-290-00155-00004				0.29	0.25	0.47	58						
3/4"	NaturalSun Low-E IG	PEL-A-290-00151-00003	3	3	air	0.33	0.49	0.59	54						
	with SDL or grilles-between-the-glass	PEL-A-290-00151-00004				0.33	0.44	0.53	54						
3/4"	NaturalSun Low-E IG	PEL-A-290-00154-00003	3	3	argon	0.30	0.49	0.59	57						
	with SDL or grilles-between-the-glass	PEL-A-290-00154-00004				0.30	0.44	0.53	57						
3/4"	NaturalSun+ Low-E IG	PEL-A-290-00253-00001	3	3	argon	0.26	0.47	0.58	45	N				35	CA
	with SDL or grilles-between-the-glass	PEL-A-290-00253-00002				0.26	0.42	0.52	45	N					
3/4"	SunDefense™ Low-E IG	PEL-A-290-00153-00003	3	3	air	0.32	0.21	0.49	55						S
	with SDL or grilles-between-the-glass	PEL-A-290-00153-00004				0.32	0.19	0.43	55						S
3/4"	SunDefense Low-E IG	PEL-A-290-00156-00003	3	3	argon	0.29	0.21	0.49	58						S
	with SDL or grilles-between-the-glass	PEL-A-290-00156-00004				0.29	0.19	0.43	58						S
3/4"	SunDefense+ Low-E IG	PEL-A-290-00254-00001	3	3	argon	0.25	0.20	0.47	46		NC	SC	S		
	with SDL or grilles-between-the-glass	PEL-A-290-00254-00002				0.25	0.18	0.42	46		NC	SC	S		
<b>Vent — with Foam Insulation</b>															
3/4"	Advanced Low-E IG	PEL-A-290-00202-00003	3	3	air	0.31	0.28	0.53	54						
	with SDL or grilles-between-the-glass	PEL-A-290-00202-00004				0.31	0.25	0.47	54						
3/4"	Advanced Low-E IG	PEL-A-290-00205-00003	3	3	argon	0.28	0.28	0.53	58						
	with SDL or grilles-between-the-glass	PEL-A-290-00205-00004				0.28	0.25	0.47	58						
3/4"	NaturalSun Low-E IG	PEL-A-290-00201-00003	3	3	air	0.32	0.49	0.59	54						
	with SDL or grilles-between-the-glass	PEL-A-290-00201-00004				0.32	0.44	0.53	54						
3/4"	NaturalSun Low-E IG	PEL-A-290-00204-00003	3	3	argon	0.29	0.49	0.59	57						
	with SDL or grilles-between-the-glass	PEL-A-290-00204-00004				0.29	0.44	0.53	57						
3/4"	NaturalSun+ Low-E IG	PEL-A-290-00265-00001	3	3	argon	0.25	0.47	0.58	45	N				36	CA
	with SDL or grilles-between-the-glass	PEL-A-290-00265-00002				0.25	0.42	0.52	45	N					
3/4"	SunDefense™ Low-E IG	PEL-A-290-00203-00003	3	3	air	0.31	0.21	0.49	55						S
	with SDL or grilles-between-the-glass	PEL-A-290-00203-00004				0.31	0.19	0.43	55						S
3/4"	SunDefense Low-E IG	PEL-A-290-00206-00003	3	3	argon	0.27	0.21	0.49	58			SC	S		
	with SDL or grilles-between-the-glass	PEL-A-290-00206-00004				0.27	0.19	0.43	58			SC	S		
3/4"	SunDefense+ Low-E IG	PEL-A-290-00266-00001	3	3	argon	0.24	0.20	0.47	47		NC	SC	S		
	with SDL or grilles-between-the-glass	PEL-A-290-00266-00002				0.24	0.18	0.42	47		NC	SC	S		
<b>Tinted Glazing</b>															
3/4"	Bronze Advanced Low-E IG	PEL-A-290-00155-00005	3	3	argon	0.29	0.28	0.39	58						
	with grilles-between-the-glass	PEL-A-290-00155-00006				0.29	0.25	0.35	58						
<b>Tinted Glazing — with Foam Insulation</b>															
3/4"	Bronze Advanced Low-E IG	PEL-A-290-00205-00005	3	3	argon	0.28	0.28	0.39	58						
	with grilles-between-the-glass	PEL-A-290-00205-00006				0.28	0.25	0.35	58						

R-Value = 1/U-Factor  
 SHGC = Solar Heat Gain Coefficient  
 VLT % = Visible Light Transmission  
 CR = Condensation Resistance  
 ER = Canadian Energy Rating

(1) Glazing performance values are calculated based on NFRC 100, NFRC 200 and NFRC 500. ENERGY STAR® values are updated to 2023 (Version 7) criteria.

(2) The values shown are based on Canada's updated ENERGY STAR® 2020 initiative.

Based on unit size, some products will use 2.5mm glass that may have improved glazing performance from what is shown.

Visit [www.energystar.gov](http://www.energystar.gov) for Energy Star guidelines.

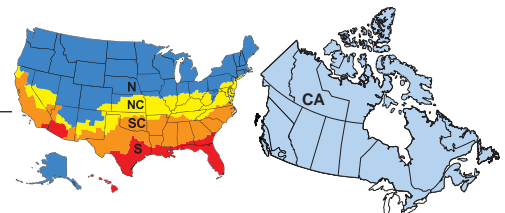



# 250 Series Double-Hung

## Glazing Performance - Total Unit

Glazing Thickness	Type of Glazing	NFRC Certified Product #	Glass (mm)			Gap Fill	Performance Values <sup>1</sup>				Shaded Areas Meet ENERGY STAR® Performance Criteria in Zones Shown						
			Ext.	Middle	Int.		U-Factor	SHGC	VLT	CR	U. S.		Canada <sup>2</sup>				
											Zone		ER	Zone			
<b>Vent — Triple-Pane</b>											N	NC	SC	S			CA
1"	Advanced Low-E Triple-pane IG	PEL-A-290-00168-00001	3	3	3	air	0.26	0.24	0.41	63							
	with Grilles-between-the-glass	PEL-A-290-00169-00001					0.26	0.21	0.36	63			SC	S			
1"	Advanced Low-E Triple-pane IG	PEL-A-290-00172-00001	3	3	3	argon	0.23	0.24	0.41	66		NC					
	with Grilles-between-the-glass	PEL-A-290-00173-00001					0.23	0.21	0.36	66		NC	SC	S			
1"	NaturalSun Low-E Triple-pane IG	PEL-A-290-00166-00001	3	3	3	air	0.27	0.42	0.52	62							
	with Grilles-between-the-glass	PEL-A-290-00167-00001					0.27	0.38	0.47	62							
1"	NaturalSun Low-E Triple-pane IG	PEL-A-290-00170-00001	3	3	3	argon	0.23	0.42	0.52	66	N						
	with Grilles-between-the-glass	PEL-A-290-00171-00001					0.24	0.38	0.47	65	N	NC					
<b>Vent — with Foam Insulation</b>												NC					
1"	Advanced Low-E Triple-pane IG	PEL-A-290-00218-00001	3	3	3	air	0.25	0.24	0.41	63		NC					
	with Grilles-between-the-glass	PEL-A-290-00219-00001					0.25	0.21	0.36	63		NC	SC	S			
1"	Advanced Low-E Triple-pane IG	PEL-A-290-00222-00001	3	3	3	argon	0.21	0.24	0.41	66	N	NC			26	CA	
	with Grilles-between-the-glass	PEL-A-290-00223-00001					0.22	0.21	0.36	66	N	NC	SC	S			
1"	NaturalSun Low-E Triple-pane IG	PEL-A-290-00216-00001	3	3	3	air	0.25	0.42	0.52	63	N						
	with Grilles-between-the-glass	PEL-A-290-00217-00001					0.26	0.38	0.47	63							
1"	NaturalSun Low-E Triple-pane IG	PEL-A-290-00220-00001	3	3	3	argon	0.22	0.42	0.52	66	N				35	CA	
	with Grilles-between-the-glass	PEL-A-290-00221-00001					0.22	0.38	0.47	66	N	NC					
<b>Vent — with Structural Reinforcement</b>																	
1"	Advanced Low-E Triple-pane IG	PEL-A-290-00193-00001	3	3	3	air	0.27	0.24	0.41	63							
	with Grilles-between-the-glass	PEL-A-290-00194-00001					0.27	0.21	0.36	62			SC	S			
1"	Advanced Low-E Triple-pane IG	PEL-A-290-00197-00001	3	3	3	argon	0.23	0.24	0.41	65		NC					
	with Grilles-between-the-glass	PEL-A-290-00198-00001					0.23	0.21	0.36	65		NC	SC	S			
1"	NaturalSun Low-E Triple-pane IG	PEL-A-290-00191-00001	3	3	3	air	0.27	0.42	0.52	62							
	with Grilles-between-the-glass	PEL-A-290-00192-00001					0.27	0.38	0.47	62							
1"	NaturalSun Low-E Triple-pane IG	PEL-A-290-00195-00001	3	3	3	argon	0.24	0.42	0.52	65	N						
	with Grilles-between-the-glass	PEL-A-290-00196-00001					0.24	0.38	0.47	65	N	NC					
<b>Vent — with Foam Insulation with Structural Reinforcement</b>																	
1"	Advanced Low-E Triple-pane IG	PEL-A-290-00243-00001	3	3	3	air	0.26	0.24	0.41	63							
	with Grilles-between-the-glass	PEL-A-290-00244-00001					0.26	0.21	0.36	63			SC	S			
1"	Advanced Low-E Triple-pane IG	PEL-A-290-00247-00001	3	3	3	argon	0.22	0.24	0.41	66	N	NC					
	with Grilles-between-the-glass	PEL-A-290-00248-00001					0.23	0.21	0.36	66		NC	SC	S			
1"	NaturalSun Low-E Triple-pane IG	PEL-A-290-00241-00001	3	3	3	air	0.26	0.42	0.52	62	N						
	with Grilles-between-the-glass	PEL-A-290-00242-00001					0.27	0.38	0.47	62							
1"	NaturalSun Low-E Triple-pane IG	PEL-A-290-00245-00001	3	3	3	argon	0.23	0.42	0.52	65	N				34	CA	
	with Grilles-between-the-glass	PEL-A-290-00246-00001					0.23	0.38	0.47	65	N	NC					

R-Value = 1/U-Factor  
 SHGC = Solar Heat Gain Coefficient  
 VLT % = Visible Light Transmission  
 CR = Condensation Resistance  
 ER = Canadian Energy Rating

(1) Glazing performance values are calculated based on NFRC 100, NFRC 200 and NFRC 500. ENERGY STAR® values are updated to 2023 (Version 7) criteria.

(2) The values shown are based on Canada's updated ENERGY STAR® 2020 initiative.

Based on unit size, some products will use 2.5mm glass that may have improved glazing performance from what is shown. Visit [www.energystar.gov](http://www.energystar.gov) for Energy Star guidelines.

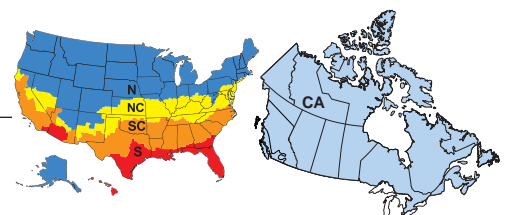



# 250 Series Double-Hung

## Glazing Performance - Total Unit

Glazing Thickness	Type of Glazing	NFRC Certified Product #	Glass (mm)		Gap Fill	Performance Values <sup>1</sup>				Shaded Areas Meet ENERGY STAR® Performance Criteria in Zones Shown					
			Ext.	Int.		U-Factor	SHGC	VLT	CR	U. S.		Canada <sup>2</sup>			
										Zone		ER	Zone		
<b>Vent — Dual-Pane with Structural Reinforcement</b>											N	NC	SC	S	CA
3/4"	Advanced Low-E IG	PEL-A-290-00177-00003	3	3	air	0.33	0.28	0.53	54						
	with SDL or grilles-between-the-glass	PEL-A-290-00177-00004				0.33	0.25	0.47	54						
3/4"	Advanced Low-E IG	PEL-A-290-00180-00003	3	3	argon	0.30	0.28	0.53	57						
	with SDL or grilles-between-the-glass	PEL-A-290-00180-00004				0.30	0.25	0.47	57						
3/4"	NaturalSun Low-E IG	PEL-A-290-00176-00003	3	3	air	0.34	0.49	0.59	53						
	with SDL or grilles-between-the-glass	PEL-A-290-00176-00004				0.34	0.44	0.53	53						
3/4"	NaturalSun Low-E IG	PEL-A-290-00179-00003	3	3	argon	0.30	0.49	0.59	57						
	with SDL or grilles-between-the-glass	PEL-A-290-00179-00004				0.30	0.44	0.53	57						
3/4"	NaturalSun+ Low-E IG	PEL-A-290-00253-00001	3	3	argon	0.26	0.47	0.58	45	N					
	with SDL or grilles-between-the-glass	PEL-A-290-00253-00002				0.26	0.42	0.52	45	N					
3/4"	SunDefense™ Low-E IG	PEL-A-290-00178-00003	3	3	air	0.33	0.21	0.49	54						
	with SDL or grilles-between-the-glass	PEL-A-290-00178-00004				0.33	0.19	0.43	54						
3/4"	SunDefense Low-E IG	PEL-A-290-00181-00003	3	3	argon	0.29	0.21	0.49	58					S	
	with SDL or grilles-between-the-glass	PEL-A-290-00181-00004				0.29	0.19	0.43	58					S	
3/4"	SunDefense+ Low-E IG	PEL-A-290-00254-00001	3	3	argon	0.25	0.20	0.47	46		NC	SC	S		
	with SDL or grilles-between-the-glass	PEL-A-290-00254-00002				0.25	0.18	0.42	46		NC	SC	S		
<b>Vent — with Foam insulation with Structural Reinforcement</b>															
3/4"	Advanced Low-E IG	PEL-A-290-00227-00003	3	3	air	0.32	0.28	0.53	54						
	with SDL or grilles-between-the-glass	PEL-A-290-00227-00004				0.32	0.25	0.47	54						
3/4"	Advanced Low-E IG	PEL-A-290-00230-00003	3	3	argon	0.29	0.28	0.53	58						
	with SDL or grilles-between-the-glass	PEL-A-290-00230-00004				0.29	0.25	0.47	58						
3/4"	NaturalSun Low-E IG	PEL-A-290-00226-00003	3	3	air	0.33	0.49	0.59	54						
	with SDL or grilles-between-the-glass	PEL-A-290-00226-00004				0.33	0.44	0.53	54						
3/4"	NaturalSun Low-E IG	PEL-A-290-00229-00003	3	3	argon	0.30	0.49	0.59	57						
	with SDL or grilles-between-the-glass	PEL-A-290-00229-00004				0.30	0.44	0.53	57						
3/4"	NaturalSun+ Low-E IG	PEL-A-290-00265-00001	3	3	argon	0.26	0.47	0.58	45	N					
	with SDL or grilles-between-the-glass	PEL-A-290-00265-00002				0.26	0.42	0.52	45	N					
3/4"	SunDefense™ Low-E IG	PEL-A-290-00228-00003	3	3	air	0.32	0.21	0.49	54					S	
	with SDL or grilles-between-the-glass	PEL-A-290-00228-00004				0.32	0.19	0.43	54					S	
3/4"	SunDefense Low-E IG	PEL-A-290-00231-00003	3	3	argon	0.28	0.21	0.49	58			SC	S		
	with SDL or grilles-between-the-glass	PEL-A-290-00231-00004				0.28	0.19	0.43	58			SC	S		
3/4"	SunDefense+ Low-E IG	PEL-A-290-00266-00001	3	3	argon	0.25	0.20	0.47	46		NC	SC	S		
	with SDL or grilles-between-the-glass	PEL-A-290-00266-00002				0.25	0.18	0.42	46		NC	SC	S		
<b>Tinted Glazing — with Structural Reinforcement</b>															
3/4"	Bronze Advanced Low-E IG	PEL-A-290-00180-00005	3	3	argon	0.30	0.28	0.39	57						
	with SDL or grilles-between-the-glass	PEL-A-290-00180-00006				0.30	0.25	0.35	57						
<b>Tinted Glazing — with Foam insulation with Structural Reinforcement</b>															
3/4"	Bronze Advanced Low-E IG	PEL-A-290-00230-00005	3	3	argon	0.29	0.28	0.39	58						
	with SDL or grilles-between-the-glass	PEL-A-290-00230-00006				0.29	0.25	0.35	58						

R-Value = 1/U-Factor  
 SHGC = Solar Heat Gain Coefficient  
 VLT % = Visible Light Transmission  
 CR = Condensation Resistance  
 ER = Canadian Energy Rating

(1) Glazing performance values are calculated based on NFRC 100, NFRC 200 and NFRC 500. ENERGY STAR® values are updated to 2023 (Version 7) criteria.

(2) The values shown are based on Canada's updated ENERGY STAR® 2020 initiative.

Based on unit size, some products will use 2.5mm glass that may have improved glazing performance from what is shown.

Visit [www.energystar.gov](http://www.energystar.gov) for Energy Star guidelines.

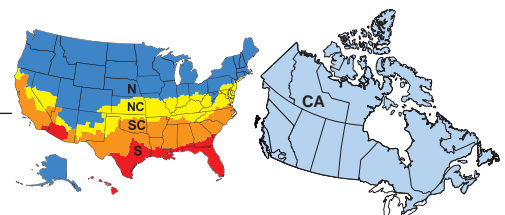



### Grille Profiles

#### Grilles-Between-the-Glass

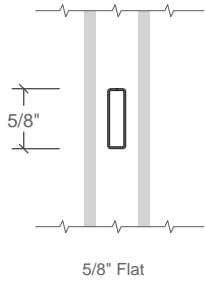

5/8" Flat

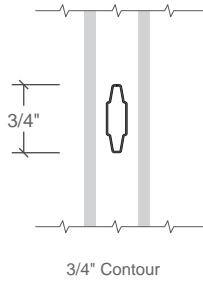

3/4" Contour

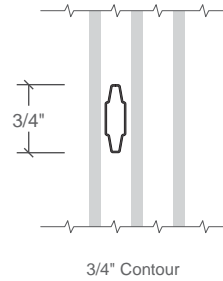

3/4" Contour

### Grille Patterns

#### Prairie Lite Patterns

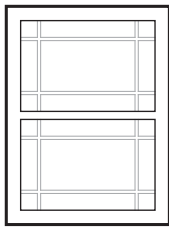

9-Lite Prairie

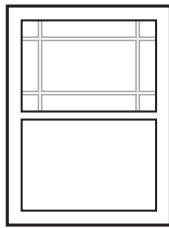

6-Lite Prairie

#### Prairie

- Specify upper or both sash
- Approximately 4" from edge of sash to center of bar
- Minimum actual glass is 13"

#### Traditional - and Custom - Equally Divided

- Specify upper or both sash
- Specify number of lites
- Grilles must be equally divided on visible glass
- Minimum 6" x 6" center-to-center

#### Top Row

- Standard visible glass to separator bar must be  $\leq 1/2$  upper actual glass

#### Other Available Patterns

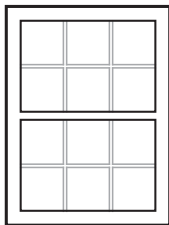

Traditional

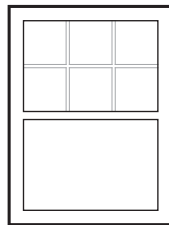

Top Row

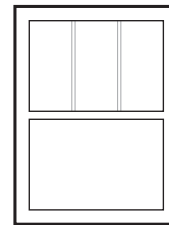

Custom—Equally Divided



# 250 Series Double-Hung

## Standard Size Tables - Equal Sash

1-Wide Vent		(610) (597)	(710) (699)	(762) (749)	(813) (800)	(914) (902)	(965) (953)	(1 067) (1 054)	(1 219) (1 207)	(1 372) (1 359)
Opening		2' 0"	2' 4"	2' 6"	2' 8"	3' 0"	3' 2"	3' 6"	4' 0"	4' 6"
Frame		23 1/2"	27 1/2"	29 1/2"	31 1/2"	35 1/2"	37 1/2"	41 1/2"	47 1/2"	53 1/2"
(914) (902)	3' 0"									
(965) (953)	3' 2"									
(1 067) (1 054)	3' 6"									
(1 168) (1 156)	3' 10"									
(1 219) (1 207)	4' 0"									
(1 321) (1 308)	4' 4"									
(1 372) (1 359)	4' 6"									
(1 524) (1 511)	5' 0"									
(1 575) (1 562)	5' 2"									
(1 676) (1 664)	5' 6"									
(1 829) (1 816)	6' 0"									
(1 981) (1 969)	6' 6"									

Not to scale.

### Egress Notes:

Check all applicable local codes for emergency egress requirements.

E = Window meets minimum clear opening of 24" height, 20" width, and 5.7 ft<sup>2</sup>.

E1 = Window meets minimum clear opening of 24" height, 20" width, and 5.0 ft<sup>2</sup>.

See Design Data pages in this section for clear opening dimensions.





# 250 Series Double-Hung

## Standard Size Tables - Equal Sash Composites

2-Wide Vent		(1 219)	(1 422)	(1 524)	(1 626)	(1 829)	(1 930)	(2 134)	(2 438)
		(1 207)	(1 410)	(1 511)	(1 613)	(1 816)	(1 918)	(2 121)	(2 426)
Opening		4' 0"	4' 8"	5' 0"	5' 4"	6' 0"	6' 4"	7' 0"	8' 0"
	Frame	47 1/2"	55 1/2"	59 1/2"	63 1/2"	71 1/2"	75 1/2"	83 1/2"	95 1/2"
(914)	3' 0"								
(902)	3' 0"	4-0/3-0	4-8/3-0	5-0/3-0	5-4/3-0	6-0/3-0	6-4/3-0	7-0/3-0	8-0/3-0
(965)	3' 2"								
(953)	3' 2"	4-0/3-2	4-8/3-2	5-0/3-2	5-4/3-2	6-0/3-2	6-4/3-2	7-0/3-2	8-0/3-2
(1 067)	3' 6"								
(1 054)	3' 6"	4-0/3-6	4-8/3-6	5-0/3-6	5-4/3-6	6-0/3-6	6-4/3-6	7-0/3-6	8-0/3-6
(1 168)	3' 10"								
(1 156)	3' 10"	4-0/3-10	4-8/3-10	5-0/3-10	5-4/3-10	6-0/3-10	6-4/3-10	7-0/3-10	8-0/3-10
(1 219)	4' 0"								
(1 207)	4' 0"	4-0/4-0	4-8/4-0	5-0/4-0	5-4/4-0	6-0/4-0	6-4/4-0	7-0/4-0	8-0/4-0
(1 321)	4' 4"								
(1 308)	4' 4"	4-0/4-4	4-8/4-4	5-0/4-4	5-4/4-4	6-0/4-4	6-4/4-4	7-0/4-4	8-0/4-4
(1 372)	4' 6"								
(1 359)	4' 6"	4-0/4-6	4-8/4-6	5-0/4-6	5-4/4-6	6-0/4-6	6-4/4-6	7-0/4-6	8-0/4-6
(1 524)	5' 0"								
(1 511)	5' 0"	4-0/5-0	4-8/5-0	5-0/5-0	5-4/5-0	6-0/5-0	6-4/5-0	7-0/5-0	8-0/5-0
(1 575)	5' 2"								
(1 562)	5' 2"	4-0/5-2	4-8/5-2	5-0/5-2	5-4/5-2	6-0/5-2	6-4/5-2	7-0/5-2	8-0/5-2
(1 676)	5' 6"								
(1 664)	5' 6"	4-0/5-6	4-8/5-6	5-0/5-6	5-4/5-6	6-0/5-6	6-4/5-6	7-0/5-6	8-0/5-6
(1 829)	6' 0"								
(1 816)	6' 0"	4-0/6-0	4-8/6-0	5-0/6-0	5-4/6-0	6-0/6-0	6-4/6-0	7-0/6-0	8-0/6-0
(1 981)	6' 6"								
(1 969)	6' 6"	4-0/6-6	4-8/6-6	5-0/6-6	5-4/6-6	6-0/6-6	6-4/6-6	7-0/6-6	8-0/6-6

Not to scale.

**Egress Notes:**

Check all applicable local codes for emergency egress requirements.

- E = Window meets minimum clear opening of 24" height, 20" width, and 5.7 ft<sup>2</sup>.
- E1 = Window meets minimum clear opening of 24" height, 20" width, and 5.0 ft<sup>2</sup>.

See Design Data pages in this section for clear opening dimensions.



# 250 Series Double-Hung

## Standard Size Tables - Equal Sash Composites

3-Wide Vent		(1 829) (1 816)	(2 134) (2 121)	(2 438) (2 426)	(2 438) (2 426)	(2 743) (2 731)	
Opening		6' 0"	7' 0"	7' 6"	8' 0"	9' 0"	
Frame		71 1/2"	83 1/2"	89 1/2"	95 1/2"	107 1/2"	
(914) (902)	3' 0"	35 1/2"	6-0/3-0	7-0/3-0	7-6/3-0	8-0/3-0	9-0/3-0
(965) (953)	3' 2"	37 1/2"	6-0/3-2	7-0/3-2	7-6/3-2	8-0/3-2	9-0/3-2
(1 067) (1 054)	3' 6"	41 1/2"	6-0/3-6	7-0/3-6	7-6/3-6	8-0/3-6	9-0/3-6
(1 1168) (1 1156)	3' 10"	45 1/2"	6-0/3-10	7-0/3-10	7-6/3-10	8-0/3-10	9-0/3-10
(1 219) (1 207)	4' 0"	47 1/2"	6-0/4-0	7-0/4-0	7-6/4-0	8-0/4-0	9-0/4-0
(1 321) (1 308)	4' 4"	51 1/2"	6-0/4-4	7-0/4-4	7-6/4-4	8-0/4-4	9-0/4-4
(1 372) (1 359)	4' 6"	53 1/2"	6-0/4-6	7-0/4-6	7-6/4-6	8-0/4-6	9-0/4-6
(1 524) (1 511)	5' 0"	59 1/2"	6-0/5-0	7-0/5-0	7-6/5-0	8-0/5-0	9-0/5-0 E <sub>1</sub>
(1 575) (1 562)	5' 2"	61 1/2"	6-0/5-2	7-0/5-2	7-6/5-2	8-0/5-2	9-0/5-2 E <sub>1</sub>
(1 676) (1 664)	5' 6"	65 1/2"	6-0/5-6	7-0/5-6	7-6/5-6	8-0/5-6 E <sub>1</sub>	
(1 829) (1 816)	6' 0"	71 1/2"	6-0/6-0	7-0/6-0	7-6/6-0		E <sub>1</sub>
(1 981) (1 969)	6' 6"	77 1/2"	6-0/6-6	7-0/6-6 E <sub>1</sub>	7-6/6-6 E <sub>1</sub>		

**Egress Notes:**

Check all applicable local codes for emergency egress requirements.

E = Window meets minimum clear opening of 24" height, 20" width, and 5.7 ft<sup>2</sup>.

E<sub>1</sub> = Window meets minimum clear opening of 24" height, 20" width, and 5.0 ft<sup>2</sup>.

See Design Data pages in this section for clear opening dimensions.

Not to scale.



# 250 Series Double-Hung

## Standard Size Tables - Cottage Sash

1-Wide Vent		(610) (597)	(710) (699)	(762) (749)	(813) (800)	(914) (902)	(965) (953)	(1 067) (1 054)	(1 219) (1 207)	(1 372) (1 359)
Opening		2' 0"	2' 4"	2' 6"	2' 8"	3' 0"	3' 2"	3' 6"	4' 0"	4' 6"
Frame		23 1/2"	27 1/2"	29 1/2"	31 1/2"	35 1/2"	37 1/2"	41 1/2"	47 1/2"	53 1/2"
(914) (902)	3' 0"	35 1/2"								
(965) (953)	3' 2"	37 1/2"								
(1 067) (1 054)	3' 6"	41 1/2"								
(1 188) (1 156)	3' 10"	45 1/2"								
(1 219) (1 207)	4' 0"	47 1/2"								
(1 321) (1 308)	4' 4"	51 1/2"								
(1 372) (1 359)	4' 6"	53 1/2"								
(1 524) (1 511)	5' 0"	59 1/2"								
(1 575) (1 562)	5' 2"	61 1/2"								
(1 676) (1 664)	5' 6"	65 1/2"								

Not to scale.



# 250 Series Double-Hung

## Standard Size Tables - Contemporary Sash



1-Wide Vent		(610) (597)	(710) (699)	(762) (749)	(813) (800)	(914) (902)	(965) (953)	(1 067) (1 054)	(1 219) (1 207)	(1 372) (1 359)
Opening		2' 0"	2' 4"	2' 6"	2' 8"	3' 0"	3' 2"	3' 6"	4' 0"	4' 6"
Frame		23 1/2"	27 1/2"	29 1/2"	31 1/2"	35 1/2"	37 1/2"	41 1/2"	47 1/2"	53 1/2"
(914) (902)	3' 0"	35 1/2"								
(965) (953)	3' 2"	37 1/2"								
(1 067) (1 054)	3' 6"	41 1/2"								
(1 168) (1 156)	3' 10"	45 1/2"								
(1 219) (1 207)	4' 0"	47 1/2"								
(1 321) (1 308)	4' 4"	51 1/2"								
(1 372) (1 359)	4' 6"	53 1/2"								
(1 524) (1 511)	5' 0"	59 1/2"								
(1 575) (1 562)	5' 2"	61 1/2"								
(1 676) (1 664)	5' 6"	65 1/2"								

Not to scale.



# 250 Series Double-Hung

## Special Sizes and Dimensions

	1-Wide Vent Unit		2-Wide Vent Unit Composite		3-Wide Vent Unit Composite	
						
	MINIMUM	MAXIMUM	MINIMUM	MAXIMUM	MINIMUM	MAXIMUM
Equal Sash	14-1/2" W x 23-1/2" H (368 x 597)	53-1/2" W x 86" H (1 359 x 2 184) 47" W x 86" H (1 194 x 2 184)* -or- 53-1/2" W x 75-1/2" H (1 359 x 1 905)*	29-1/2" W x 23-1/2" H (749 x 597)	95-1/2" W x 78" H (2 426 x 1 981)	44-1/2" W x 23-1/2" H (1 130 x 597)	107-1/2" W x 78" H (2 731 x 1 981)
Cottage Sash	14-1/2" W x 28-1/2" H (368 x 724)	53-1/2" W x 72.5" H (1 359 x 1 842)	29-1/2" W x 28-1/2" H (749 x 724)	95-1/2" W x 65-1/2" H (2 426 x 1 664)	44-1/2" W x 28-1/2" H (1 130 x 724)	107-1/2" W x 65-1/2" H (2 731 x 1 664)
Contemporary Sash	14-1/2" W x 28-1/2" H (368 x 724)	53-1/2" W x 72.5" H (1 359 x 1 842) 48" W x 72.5" H (1 219 x 1 842)* -or- 53-1/2" W x 64-1/2" H (1 359 x 1 638)*	29-1/2" W x 28-1/2" H (749 x 724)	95-1/2" W x 65-1/2" H (2 426 x 1 664)	44-1/2" W x 28-1/2" H (1 130 x 724)	107-1/2" W x 65-1/2" H (2 731 x 1 664)

\*Only available for units with Auto-Lock.

### General Notes:

- Maximum frame size for 2-Wide = 48 Ft<sup>2</sup> (4.46 m<sup>2</sup>)
- Maximum frame size for 3-Wide = 54 Ft<sup>2</sup> (5.01 m<sup>2</sup>)
- Rough Opening = Frame Dimension + 1/2"
- Keep frame dimensions to the nearest 1/8" increment
- 2-Wide and 3-Wide units are composites with multiple windows in one frame with integral mullions
- Sizes shown are for dual-pane 3 mm (annealed glass), other glass configurations affect maximum size available, contact your sales representative for details.
- Sizes shown are region dependent, contact your sales representative for offering details.

### Miscellaneous Formulas

	Standard Performance Actual Glass Width	Actual Glass Height		Standard Performance Visible Glass Width	Performance Upgrade Visible Glass Width	Visible Glass Height
		Lower Glass	Upper Glass			
1-Wide	Vent-equal		(FH - 6) ÷ 2	(FH - 6) ÷ 2		
	Cottage	FW - 5-1/4"	(FH - 6) X .6	(FH - 6) X .4	AGW - 1-1/8"	AGH - 1-1/8"
	Contemporary		(FH - 6) X .4	(FH - 6) X .6		
2-Wide	Vent-equal		(FH - 6) ÷ 2	(FH - 6) ÷ 2		
	Cottage	(FW ÷ 2) - 5-1/2"	(FH - 6) X .6	(FH - 6) X .4	AGW - 1-1/8"	AGW - 1-1/8"
	Contemporary		(FH - 6) X .4	(FH - 6) X .6		
3-Wide	Vent-equal		(FH - 6) ÷ 2	(FH - 6) ÷ 2		
	Cottage	(FW ÷ 3) - 5-19/32"	(FH - 6) X .6	(FH - 6) X .4	AGW - 1-1/8"	AGW - 1-1/8"
	Contemporary		(FH - 6) X .4	(FH - 6) X .6		

### Clear Opening Formulas

	COW	COH Equal Vent	COH Cottage Vent	COH Contemporary Vent
Clear opening with Cam Lock	Frame Width - 5.046	(FH ÷ 2) - 5.411	FH - ALGH - 8.411	FH - AUGH - 8.518
Clear opening with Auto Lock		(FH ÷ 2) - 5.411	FH - ALGH - 8.411	FH - AUGH - 8.518

- Clear Opening Area (ft<sup>2</sup>) = (COW x COH) ÷ 144
- Frame Area (ft<sup>2</sup>) = (Frame Width x Frame Height) ÷ 144

KEY: AGW = Actual Glass Width  
AGH = Actual Glass Height  
ALGH = Actual Lower Glass Height  
AUGH = Actual Upper Glass Height  
FW = Frame Width  
FH = Frame Height  
VGV = Visible Glass Width  
VGH = Visible Glass Height  
COW = Clear opening width  
COH = Clear opening height



# 250 Series Double-Hung

## Design Data

1-Wide Vent Units — Equal Sash											
Unit	Egress	Frame (Inches)		Clear Opening (Vent Units Only) (Inches)			Visible Glass Ft <sup>2</sup>	Glass Thickness (mm)		Performance Class & Grade <sup>(1)</sup>	
		Width	Height	Width	Height	Ft <sup>2</sup>		Annealed	Tempered	Standard	Upgrade
2-0/3-0		23-1/2	35-1/2	18-7/16	12-5/16	1.5	3.3	2.5	3.0	R35	R50
2-0/3-2		23-1/2	37-1/2	18-7/16	13-5/16	1.7	3.5	2.5	3.0	R35	R50
2-0/3-6		23-1/2	41-1/2	18-7/16	15-5/16	1.9	4.0	2.5	3.0	R35	R50
2-0/3-10		23-1/2	45-1/2	18-7/16	17-5/16	2.2	4.5	2.5	3.0	R35	R50
2-0/4-0		23-1/2	47-1/2	18-7/16	18-5/16	2.3	4.7	2.5	3.0	R35	R50
2-0/4-4		23-1/2	51-1/2	18-7/16	20-5/16	2.6	5.2	2.5	3.0	R35	R50
2-0/4-6		23-1/2	53-1/2	18-7/16	21-5/16	2.7	5.5	2.5	3.0	R35	R50
2-0/5-0		23-1/2	59-1/2	18-7/16	24-5/16	3.1	6.2	2.5	3.0	R35	R50
2-0/5-2		23-1/2	61-1/2	18-7/16	25-5/16	3.2	6.4	2.5	3.0	R35	R50
2-0/5-6		23-1/2	65-1/2	18-7/16	27-5/16	3.5	6.9	2.5	3.0	R30	R50
2-0/6-0		23-1/2	71-1/2	18-7/16	30-5/16	3.8	7.6	2.5	3.0	R30	R50
2-0/6-6		23-1/2	77-1/2	18-7/16	33-5/16	4.2	8.3	2.5	3.0	R20	R50
2-4/3-0		27-1/2	35-1/2	22-7/16	12-5/16	1.9	4.1	2.5	3.0	R35	R50
2-4/3-2		27-1/2	37-1/2	22-7/16	13-5/16	2.0	4.4	2.5	3.0	R35	R50
2-4/3-6		27-1/2	41-1/2	22-7/16	15-5/16	2.3	4.9	2.5	3.0	R35	R50
2-4/3-10		27-1/2	45-1/2	22-7/16	17-5/16	2.7	5.5	2.5	3.0	R35	R50
2-4/4-0		27-1/2	47-1/2	22-7/16	18-5/16	2.8	5.8	2.5	3.0	R35	R50
2-4/4-4		27-1/2	51-1/2	22-7/16	20-5/16	3.1	6.4	2.5	3.0	R35	R50
2-4/4-6		27-1/2	53-1/2	22-7/16	21-5/16	3.3	6.7	2.5	3.0	R35	R50
2-4/5-0		27-1/2	59-1/2	22-7/16	24-5/16	3.7	7.6	2.5	3.0	R35	R50
2-4/5-2		27-1/2	61-1/2	22-7/16	25-5/16	3.9	7.9	2.5	3.0	R35	R50
2-4/5-6		27-1/2	65-1/2	22-7/16	27-5/16	4.2	8.5	2.5	3.0	R30	R50
2-4/6-0		27-1/2	71-1/2	22-7/16	30-5/16	4.7	9.4	2.5	3.0	R30	R50
2-4/6-6	E1	27-1/2	77-1/2	22-7/16	33-5/16	5.1	10.3	2.5	3.0	R20	R50
2-6/3-0		29-1/2	35-1/2	24-1/4	12-5/16	2.0	4.4	2.5	3.0	R35	R50
2-6/3-2		29-1/2	37-1/2	24-1/4	13-5/16	2.2	4.8	2.5	3.0	R35	R50
2-6/3-6		29-1/2	41-1/2	24-1/4	15-5/16	2.6	5.4	2.5	3.0	R35	R50
2-6/3-10		29-1/2	45-1/2	24-1/4	17-5/16	2.9	6.1	2.5	3.0	R35	R50
2-6/4-0		29-1/2	47-1/2	24-1/4	18-5/16	3.1	6.4	2.5	3.0	R35	R50
2-6/4-4		29-1/2	51-1/2	24-1/4	20-5/16	3.4	7.0	2.5	3.0	R35	R50
2-6/4-6		29-1/2	53-1/2	24-1/4	21-5/16	3.6	7.3	2.5	3.0	R35	R50
2-6/5-0		29-1/2	59-1/2	24-1/4	24-5/16	4.1	8.3	2.5	3.0	R35	R50
2-6/5-2		29-1/2	61-1/2	24-1/4	25-5/16	4.3	8.6	2.5	3.0	R35	R50
2-6/5-6		29-1/2	65-1/2	24-1/4	27-5/16	4.6	9.3	2.5	3.0	R30	R50
2-6/6-0	E1	29-1/2	71-1/2	24-1/4	30-5/16	5.1	10.3	2.5	3.0	R30	R50
2-6/6-6	E1	29-1/2	77-1/2	24-1/4	33-5/16	5.6	11.2	2.5	3.0	R20	R50
2-8/3-0		31-1/2	35-1/2	26-7/16	12-5/16	2.2	4.8	2.5	3.0	R35	R50
2-8/3-2		31-1/2	37-1/2	26-7/16	13-5/16	2.4	5.2	2.5	3.0	R35	R50
2-8/3-6		31-1/2	41-1/2	26-7/16	15-5/16	2.8	5.9	2.5	3.0	R35	R50
2-8/3-10		31-1/2	45-1/2	26-7/16	17-5/16	3.1	6.6	2.5	3.0	R35	R50
2-8/4-0		31-1/2	47-1/2	26-7/16	18-5/16	3.3	6.9	2.5	3.0	R35	R50
2-8/4-4		31-1/2	51-1/2	26-7/16	20-5/16	3.7	7.6	2.5	3.0	R35	R50
2-8/4-6		31-1/2	53-1/2	26-7/16	21-5/16	3.9	8.0	2.5	3.0	R35	R50
2-8/5-0		31-1/2	59-1/2	26-7/16	24-5/16	4.4	9.0	2.5	3.0	R35	R50
2-8/5-2		31-1/2	61-1/2	26-7/16	25-5/16	4.6	9.4	2.5	3.0	R35	R50
2-8/5-6	E1	31-1/2	65-1/2	26-7/16	27-5/16	5.0	10.1	2.5	3.0	R30	R50
2-8/6-0	E1	31-1/2	71-1/2	26-7/16	30-5/16	5.5	11.1	2.5	3.0	R30	R50
2-8/6-6	E	31-1/2	77-1/2	26-7/16	33-5/16	6.1	12.2	2.5	3.0	R20	R50

**Egress Notes:**

Check all applicable local codes for emergency egress requirements.

E = Window meets minimum clear opening of 24" height, 20" width, and 5.7 ft<sup>2</sup>.

E1 = Window meets minimum clear opening of 24" height, 20" width, and 5.0 ft<sup>2</sup>.

To convert areas to square meters (m<sup>2</sup>), multiply square feet by 0.0929.

(-) = Not Available

(1) Maximum performance when glazed with the appropriate glass thickness.



# 250 Series Double-Hung

## Design Data

1-Wide Vent Units — Equal Sash											
Unit	Egress	Frame (Inches)		Clear Opening (Vent Units Only) (Inches)			Visible Glass Ft <sup>2</sup>	Glass Thickness (mm)		Performance Class & Grade <sup>(1)</sup>	
		Width	Height	Width	Height	Ft <sup>2</sup>		Annealed	Tempered	Standard	Upgrade
3-0/3-0		35-1/2	35-1/2	30-7/16	12-5/16	2.6	5.6	2.5	3.0	R35	R50
3-0/3-2		35-1/2	37-1/2	30-7/16	13-5/16	2.8	6.0	2.5	3.0	R35	R50
3-0/3-6		35-1/2	41-1/2	30-7/16	15-5/16	3.2	6.8	2.5	3.0	R35	R50
3-0/3-10		35-1/2	45-1/2	30-7/16	17-5/16	3.6	7.6	2.5	3.0	R35	R50
3-0/4-0		35-1/2	47-1/2	30-7/16	18-5/16	3.8	8.0	2.5	3.0	R35	R50
3-0/4-4		35-1/2	51-1/2	30-7/16	20-5/16	4.3	8.8	2.5	3.0	R35	R50
3-0/4-6		35-1/2	53-1/2	30-7/16	21-5/16	4.5	9.2	2.5	3.0	R35	R50
3-0/5-0	E1	35-1/2	59-1/2	30-7/16	24-5/16	5.1	10.5	2.5	3.0	R35	R50
3-0/5-2	E1	35-1/2	61-1/2	30-7/16	25-5/16	5.3	10.9	2.5	3.0	R35	R50
3-0/5-6	E	35-1/2	65-1/2	30-7/16	27-5/16	5.7	11.7	2.5	3.0	R30	R50
3-0/6-0	E	35-1/2	71-1/2	30-7/16	30-5/16	6.4	12.9	2.5	3.0	R30	R50
3-0/6-6	E	35-1/2	77-1/2	30-7/16	33-5/16	7.0	14.1	2.5	3.0	R20	R50
3-2/3-0		37-1/2	35-1/2	32-7/16	12-5/16	2.7	6.0	2.5	3.0	R30	R50
3-2/3-2		37-1/2	37-1/2	32-7/16	13-5/16	3.0	6.4	2.5	3.0	R30	R50
3-2/3-6		37-1/2	41-1/2	32-7/16	15-5/16	3.4	7.3	2.5	3.0	R30	R50
3-2/3-10		37-1/2	45-1/2	32-7/16	17-5/16	3.9	8.1	2.5	3.0	R30	R50
3-2/4-0		37-1/2	47-1/2	32-7/16	18-5/16	4.1	8.6	2.5	3.0	R30	R50
3-2/4-4		37-1/2	51-1/2	32-7/16	20-5/16	4.5	9.4	2.5	3.0	R30	R50
3-2/4-6		37-1/2	53-1/2	32-7/16	21-5/16	4.8	9.9	2.5	3.0	R30	R50
3-2/5-0	E1	37-1/2	59-1/2	32-7/16	24-5/16	5.4	11.2	2.5	3.0	R30	R50
3-2/5-2	E	37-1/2	61-1/2	32-7/16	25-5/16	5.7	11.6	2.5	3.0	R30	R50
3-2/5-6	E	37-1/2	65-1/2	32-7/16	27-5/16	6.1	12.5	2.5	3.0	R20	R50
3-2/6-0	E	37-1/2	71-1/2	32-7/16	30-5/16	6.8	13.8	2.5	3.0	R20	R50
3-2/6-6	E	37-1/2	77-1/2	32-7/16	33-5/16	7.5	15.1	2.5	3.0	R20	R50
3-6/3-0		41-1/2	35-1/2	36-7/16	12-5/16	3.1	6.7	2.5	3.0	R30	R50
3-6/3-2		41-1/2	37-1/2	36-7/16	13-5/16	3.3	7.2	2.5	3.0	R30	R50
3-6/3-6		41-1/2	41-1/2	36-7/16	15-5/16	3.8	8.2	2.5	3.0	R30	R50
3-6/3-10		41-1/2	45-1/2	36-7/16	17-5/16	4.3	9.2	2.5	3.0	R30	R50
3-6/4-0		41-1/2	47-1/2	36-7/16	18-5/16	4.6	9.7	2.5	3.0	R30	R50
3-6/4-4		41-1/2	51-1/2	36-7/16	20-5/16	5.1	10.6	2.5	3.0	R30	R50
3-6/4-6		41-1/2	53-1/2	36-7/16	21-5/16	5.4	11.1	2.5	3.0	R30	R50
3-6/5-0	E	41-1/2	59-1/2	36-7/16	24-5/16	6.1	12.6	2.5	3.0	R30	R50
3-6/5-2	E	41-1/2	61-1/2	36-7/16	25-5/16	6.4	13.1	2.5	3.0	R30	R50
3-6/5-6	E	41-1/2	65-1/2	36-7/16	27-5/16	6.9	14.1	2.5	3.0	R20	R50
3-6/6-0	E	41-1/2	71-1/2	36-7/16	30-5/16	7.6	15.5	2.5	3.0	R20	R50
3-6/6-6	E	41-1/2	77-1/2	36-7/16	33-5/16	8.4	17.0	2.5	3.0	R20	R50
4-0/3-0		47-1/2	35-1/2	42-7/16	12-5/16	3.6	7.9	2.5	3.0	R30	R50
4-0/3-2		47-1/2	37-1/2	42-7/16	13-5/16	3.9	8.5	2.5	3.0	R30	R50
4-0/3-6		47-1/2	41-1/2	42-7/16	15-5/16	4.5	9.6	2.5	3.0	R30	R50
4-0/3-10		47-1/2	45-1/2	42-7/16	17-5/16	5.1	10.7	2.5	3.0	R30	R50
4-0/4-0		47-1/2	47-1/2	42-7/16	18-5/16	5.4	11.3	2.5	3.0	R30	R50
4-0/4-4		47-1/2	51-1/2	42-7/16	20-5/16	5.9	12.5	2.5	3.0	R30	R50
4-0/4-6		47-1/2	53-1/2	42-7/16	21-5/16	6.2	13.0	2.5	3.0	R30	R50
4-0/5-0	E	47-1/2	59-1/2	42-7/16	24-5/16	7.1	14.8	2.5	3.0	R30	R50
4-0/5-2	E	47-1/2	61-1/2	42-7/16	25-5/16	7.4	15.3	2.5	3.0	R30	R50
4-0/5-6	E	47-1/2	65-1/2	42-7/16	27-5/16	8.0	16.5	2.5	3.0	R20	R50
4-0/6-0	E	47-1/2	71-1/2	42-7/16	30-5/16	8.9	18.2	2.5	3.0	R20	R50
4-0/6-6	E	47-1/2	77-1/2	42-7/16	33-5/16	9.8	19.9	2.5	3.0	R20	—
4-6/3-0		53-1/2	35-1/2	48-7/16	12-5/16	4.1	9.0	2.5	3.0	R20	—
4-6/3-2		53-1/2	37-1/2	48-7/16	13-5/16	4.4	9.7	2.5	3.0	R20	—
4-6/3-6		53-1/2	41-1/2	48-7/16	15-5/16	5.1	11.0	2.5	3.0	R20	—
4-6/3-10		53-1/2	45-1/2	48-7/16	17-5/16	5.8	12.3	2.5	3.0	R20	—
4-6/4-0		53-1/2	47-1/2	48-7/16	18-5/16	6.1	13.0	2.5	3.0	R20	—
4-6/4-4		53-1/2	51-1/2	48-7/16	20-5/16	6.8	14.3	2.5	3.0	R20	—
4-6/4-6		53-1/2	53-1/2	48-7/16	21-5/16	7.1	14.9	2.5	3.0	R20	—
4-6/5-0	E	53-1/2	59-1/2	48-7/16	24-5/16	8.1	16.9	2.5	3.0	R20	—
4-6/5-2	E	53-1/2	61-1/2	48-7/16	25-5/16	8.5	17.6	2.5	3.0	R20	—
4-6/5-6	E	53-1/2	65-1/2	48-7/16	27-5/16	9.1	18.9	2.5	3.0	R20	—
4-6/6-0	E	53-1/2	71-1/2	48-7/16	30-5/16	10.2	20.8	2.5	3.0	R20	—
4-6/6-6	E	53-1/2	77-1/2	48-7/16	33-5/16	11.2	22.8	2.5	3.0	R20	—

**Egress Notes:**  
 Check all applicable local codes for emergency egress requirements.

E = Window meets minimum clear opening of 24" height, 20" width, and 5.7 ft<sup>2</sup>.

E1 = Window meets minimum clear opening of 24" height, 20" width, and 5.0 ft<sup>2</sup>.

To convert areas to square meters (m<sup>2</sup>), multiply square feet by 0.0929.

(-) = Not Available

(1) Maximum performance when glazed with the appropriate glass thickness.



# 250 Series Double-Hung

## Design Data

2-WIDE VENT UNIT COMPOSITES WITH INTEGRAL MULLION – EQUAL SASH											
Unit	Egress	Frame (Inches)		Clear Opening (Vent Units Only) (Inches)			Visible Glass Ft <sup>2</sup>	Glass Thickness (mm)		Performance Class & Grade <sup>1</sup>	
		Width	Height	Width	Height	Ft <sup>2</sup>		Annealed	Tempered	Standard	Upgrade
4-0/3-0		47-1/2	35-1/2	18-7/16	12-5/16	1.5	6.6	2.5	3.0	R35	R50
4-0/3-2		47-1/2	37-1/2	18-7/16	13-5/16	1.7	7.1	2.5	3.0	R35	R50
4-0/3-6		47-1/2	41-1/2	18-7/16	15-5/16	1.9	8.0	2.5	3.0	R35	R50
4-0/3-10		47-1/2	45-1/2	18-7/16	17-5/16	2.2	9.0	2.5	3.0	R35	R50
4-0/4-0		47-1/2	47-1/2	18-7/16	18-5/16	2.3	9.5	2.5	3.0	R35	R50
4-0/4-4		47-1/2	51-1/2	18-7/16	20-5/16	2.6	10.4	2.5	3.0	R35	R50
4-0/4-6		47-1/2	53-1/2	18-7/16	21-5/16	2.7	10.9	2.5	3.0	R35	R50
4-0/5-0		47-1/2	59-1/2	18-7/16	24-5/16	3.1	12.3	2.5	3.0	R35	R50
4-0/5-2		47-1/2	61-1/2	18-7/16	25-5/16	3.2	12.8	2.5	3.0	R35	R50
4-0/5-6		47-1/2	65-1/2	18-7/16	27-5/16	3.5	13.8	2.5	3.0	R30	R50
4-0/6-0		47-1/2	71-1/2	18-7/16	30-5/16	3.8	15.2	2.5	3.0	R30	R50
4-0/6-6		47-1/2	77-1/2	18-7/16	33-5/16	4.2	16.7	2.5	3.0	R20	—
4-8/3-0		55-1/2	35-1/2	22-7/16	12-5/16	1.9	8.1	2.5	3.0	R35	R50
4-8/3-2		55-1/2	37-1/2	22-7/16	13-5/16	2.0	8.7	2.5	3.0	R35	R50
4-8/3-6		55-1/2	41-1/2	22-7/16	15-5/16	2.3	9.9	2.5	3.0	R35	R50
4-8/3-10		55-1/2	45-1/2	22-7/16	17-5/16	2.7	11.1	2.5	3.0	R35	R50
4-8/4-0		55-1/2	47-1/2	22-7/16	18-5/16	2.8	11.7	2.5	3.0	R35	R50
4-8/4-4		55-1/2	51-1/2	22-7/16	20-5/16	3.1	12.8	2.5	3.0	R35	R50
4-8/4-6		55-1/2	53-1/2	22-7/16	21-5/16	3.3	13.4	2.5	3.0	R35	R50
4-8/5-0		55-1/2	59-1/2	22-7/16	24-5/16	3.7	15.2	2.5	3.0	R35	R50
4-8/5-2		55-1/2	61-1/2	22-7/16	25-5/16	3.9	15.8	2.5	3.0	R35	R50
4-8/5-6		55-1/2	65-1/2	22-7/16	27-5/16	4.2	17.0	2.5	3.0	R30	R50
4-8/6-0		55-1/2	71-1/2	22-7/16	30-5/16	4.7	18.7	2.5	3.0	R30	R50
4-8/6-6	E1	55-1/2	77-1/2	22-7/16	33-5/16	5.1	20.5	2.5	3.0	R20	—
5-0/3-0		59-1/2	35-1/2	24-7/16	12-5/16	2.0	8.9	2.5	3.0	R35	R50
5-0/3-2		59-1/2	37-1/2	24-7/16	13-5/16	2.2	9.5	2.5	3.0	R35	R50
5-0/3-6		59-1/2	41-1/2	24-7/16	15-5/16	2.6	10.8	2.5	3.0	R35	R50
5-0/3-10		59-1/2	45-1/2	24-7/16	17-5/16	2.9	12.1	2.5	3.0	R35	R50
5-0/4-0		59-1/2	47-1/2	24-7/16	18-5/16	3.1	12.8	2.5	3.0	R35	R50
5-0/4-4		59-1/2	51-1/2	24-7/16	20-5/16	3.4	14.0	2.5	3.0	R35	R50
5-0/4-6		59-1/2	53-1/2	24-7/16	21-5/16	3.6	14.7	2.5	3.0	R35	R50
5-0/5-0		59-1/2	59-1/2	24-7/16	24-5/16	4.1	16.6	2.5	3.0	R35	R50
5-0/5-2		59-1/2	61-1/2	24-7/16	25-5/16	4.3	17.3	2.5	3.0	R35	R50
5-0/5-6		59-1/2	65-1/2	24-7/16	27-5/16	4.6	18.6	2.5	3.0	R30	R50
5-0/6-0	E1	59-1/2	71-1/2	24-7/16	30-5/16	5.1	20.5	2.5	3.0	R30	R50
5-0/6-6	E1	59-1/2	77-1/2	24-7/16	33-5/16	5.6	22.4	2.5	3.0	R20	-
5-4/3-0		63-1/2	35-1/2	26-7/16	12-5/16	2.2	9.6	2.5	3.0	R35	R50
5-4/3-2		63-1/2	37-1/2	26-7/16	13-5/16	2.4	10.3	2.5	3.0	R35	R50
5-4/3-6		63-1/2	41-1/2	26-7/16	15-5/16	2.8	11.7	2.5	3.0	R35	R50
5-4/3-10		63-1/2	45-1/2	26-7/16	17-5/16	3.1	13.2	2.5	3.0	R35	R50
5-4/4-0		63-1/2	47-1/2	26-7/16	18-5/16	3.3	13.9	2.5	3.0	R35	R50
5-4/4-4		63-1/2	51-1/2	26-7/16	20-5/16	3.7	15.3	2.5	3.0	R35	R50
5-4/4-6		63-1/2	53-1/2	26-7/16	21-5/16	3.9	16.0	2.5	3.0	R35	R50
5-4/5-0		63-1/2	59-1/2	26-7/16	24-5/16	4.4	18.1	2.5	3.0	R35	R50
5-4/5-2		63-1/2	61-1/2	26-7/16	25-5/16	4.6	18.8	2.5	3.0	R35	R50
5-4/5-6	E1	63-1/2	65-1/2	26-7/16	27-5/16	5.0	20.2	2.5	3.0	R30	R50
5-4/6-0	E1	63-1/2	71-1/2	26-7/16	30-5/16	5.5	22.3	2.5	3.0	R30	R50
5-4/6-6	E	63-1/2	77-1/2	26-7/16	33-5/16	6.1	24.4	2.5	3.0	R20	—

**Egress Notes:**

Check all applicable local codes for emergency egress requirements.

E = Window meets minimum clear opening of 24" height, 20" width, and 5.7 ft<sup>2</sup>.

E1 = Window meets minimum clear opening of 24" height, 20" width, and 5.0 ft<sup>2</sup>.

To convert areas to square meters (m<sup>2</sup>), multiply square feet by 0.0929.

(-) = Not Available

(1) Maximum performance when glazed with the appropriate glass thickness.





# 250 Series Double-Hung

## Design Data

2-WIDE VENT UNIT COMPOSITES WITH INTEGRAL MULLION – EQUAL SASH											
Unit	Egress	Frame (Inches)		Clear Opening (Vent Units Only) (Inches)			Visible Glass Ft <sup>2</sup>	Glass Thickness (mm)		Performance Class & Grade <sup>(1)</sup>	
		Width	Height	Width	Height	Ft <sup>2</sup>		Annealed	Tempered	Standard	Upgrade
6-0/3-0		71-1/2	35-1/2	30-7/16	12-5/16	2.6	11.2	2.5	3.0	R35	R50
6-0/3-2		71-1/2	37-1/2	30-7/16	13-5/16	2.8	12.0	2.5	3.0	R35	R50
6-0/3-6		71-1/2	41-1/2	30-7/16	15-5/16	3.2	13.6	2.5	3.0	R35	R50
6-0/3-10		71-1/2	45-1/2	30-7/16	17-5/16	3.6	15.2	2.5	3.0	R35	R50
6-0/4-0		71-1/2	47-1/2	30-7/16	18-5/16	3.8	16.0	2.5	3.0	R35	R50
6-0/4-4		71-1/2	51-1/2	30-7/16	20-5/16	4.3	17.7	2.5	3.0	R35	R50
6-0/4-6		71-1/2	53-1/2	30-7/16	21-5/16	4.5	18.5	2.5	3.0	R35	R50
6-0/5-0	E1	71-1/2	59-1/2	30-7/16	24-5/16	5.1	20.9	2.5	3.0	R35	R50
6-0/5-2	E1	71-1/2	61-1/2	30-7/16	25-5/16	5.3	21.7	2.5	3.0	R35	R50
6-0/5-6	E	71-1/2	65-1/2	30-7/16	27-5/16	5.7	23.4	2.5	3.0	R30	R50
6-0/6-0	E	71-1/2	71-1/2	30-7/16	30-5/16	6.4	25.8	2.5	3.0	R30	R50
6-0/6-6	E	71-1/2	77-1/2	30-7/16	33-5/16	7.0	28.2	2.5	3.0	R20	–
6-4/3-0		75-1/2	35-1/2	32-7/16	12-5/16	2.7	11.9	2.5	3.0	R30	–
6-4/3-2		75-1/2	37-1/2	32-7/16	13-5/16	3.0	12.8	2.5	3.0	R30	–
6-4/3-6		75-1/2	41-1/2	32-7/16	15-5/16	3.4	14.5	2.5	3.0	R30	–
6-4/3-10		75-1/2	45-1/2	32-7/16	17-5/16	3.9	16.3	2.5	3.0	R30	–
6-4/4-0		75-1/2	47-1/2	32-7/16	18-5/16	4.1	17.1	2.5	3.0	R30	–
6-4/4-4		75-1/2	51-1/2	32-7/16	20-5/16	4.5	18.9	2.5	3.0	R30	–
6-4/4-6		75-1/2	53-1/2	32-7/16	21-5/16	4.8	19.7	2.5	3.0	R30	–
6-4/5-0	E1	75-1/2	59-1/2	32-7/16	24-5/16	5.4	22.4	2.5	3.0	R30	–
6-4/5-2	E	75-1/2	61-1/2	32-7/16	25-5/16	5.7	23.2	2.5	3.0	R30	–
6-4/5-6		75-1/2	65-1/2	32-7/16	27-5/16	6.1	25.0	2.5	3.0	R20	–
6-4/6-0		75-1/2	71-1/2	32-7/16	30-5/16	6.8	27.6	2.5	3.0	R20	–
6-4/6-6	E	75-1/2	77-1/2	32-7/16	33-5/16	7.5	30.2	2.5	3.0	R20	–
7-0/3-0		83-1/2	35-1/2	42-7/16	12-5/16	3.1	13.5	2.5	3.0	R30	–
7-0/3-2		83-1/2	37-1/2	42-7/16	13-5/16	3.3	14.4	2.5	3.0	R30	–
7-0/3-6		83-1/2	41-1/2	42-7/16	15-5/16	3.8	16.4	2.5	3.0	R30	–
7-0/3-10		83-1/2	45-1/2	42-7/16	17-5/16	4.3	18.4	2.5	3.0	R30	–
7-0/4-0		83-1/2	47-1/2	42-7/16	18-5/16	4.6	19.3	2.5	3.0	R30	–
7-0/4-4		83-1/2	51-1/2	42-7/16	20-5/16	5.1	21.3	2.5	3.0	R30	–
7-0/4-6		83-1/2	53-1/2	42-7/16	21-5/16	5.4	22.3	2.5	3.0	R30	–
7-0/5-0	E	83-1/2	59-1/2	42-7/16	24-5/16	6.1	25.2	2.5	3.0	R30	–
7-0/5-2		83-1/2	61-1/2	42-7/16	25-5/16	6.4	26.2	2.5	3.0	R30	–
7-0/5-6		83-1/2	65-1/2	42-7/16	27-5/16	6.9	28.2	2.5	3.0	R20	–
7-0/6-0		83-1/2	71-1/2	42-7/16	30-5/16	7.6	31.1	2.5	3.0	R20	–
7-0/6-6	E	83-1/2	77-1/2	42-7/16	33-5/16	8.4	34.0	2.5	3.0	R20	–
8-0/3-0		95-1/2	35-1/2	48-7/16	12-5/16	3.6	15.8	2.5	3.0	R30	–
8-0/3-2		95-1/2	37-1/2	48-7/16	13-5/16	3.9	16.9	2.5	3.0	R30	–
8-0/3-6		95-1/2	41-1/2	48-7/16	15-5/16	4.5	19.2	2.5	3.0	R30	–
8-0/3-10		95-1/2	45-1/2	48-7/16	17-5/16	5.1	21.5	2.5	3.0	R30	–
8-0/4-0		95-1/2	47-1/2	48-7/16	18-5/16	5.4	22.6	2.5	3.0	R30	–
8-0/4-4		95-1/2	51-1/2	48-7/16	20-5/16	5.9	24.9	2.5	3.0	R30	–
8-0/4-6		95-1/2	53-1/2	48-7/16	21-5/16	6.2	26.1	2.5	3.0	R30	–
8-0/5-0	E	95-1/2	59-1/2	48-7/16	24-5/16	7.1	29.5	2.5	3.0	R30	–
8-0/5-2	E	95-1/2	61-1/2	48-7/16	25-5/16	7.4	30.7	2.5	3.0	R30	–
8-0/5-6	E	95-1/2	65-1/2	48-7/16	27-5/16	8.0	32.9	2.5	3.0	R20	–
8-0/6-0	E	95-1/2	71-1/2	48-7/16	30-5/16	8.9	36.4	2.5	3.0	R20	–

**Egress Notes:**

Check all applicable local codes for emergency egress requirements.

E = Window meets minimum clear opening of 24" height, 20" width, and 5.7 ft<sup>2</sup>.

E1 = Window meets minimum clear opening of 24" height, 20" width, and 5.0 ft<sup>2</sup>.

To convert areas to square meters (m<sup>2</sup>), multiply square feet by 0.0929.

(–) = Not Available

(1) Maximum performance when glazed with the appropriate glass thickness.



# 250 Series Double-Hung

## Design Data

3-Wide Vent Unit Composites with Integral Mullion — Equal Sash											
Unit	Egress	Frame (Inches)		Clear Opening (Vent Units Only) (Inches)			Visible Glass Ft <sup>2</sup>	Glass Thickness (mm)		Performance Class & Grade <sup>(1)</sup>	
		Width	Height	Width	Height	Ft <sup>2</sup>		Annealed	Tempered	Standard	Upgrade
6-0/3-0		71-1/2	35-1/2	18-7/16	12-5/16	1.5	9.9	2.5	3.0	R35	—
6-0/3-2		71-1/2	37-1/2	18-7/16	13-5/16	1.7	10.6	2.5	3.0	R35	—
6-0/3-6		71-1/2	41-1/2	18-7/16	15-5/16	1.9	12.0	2.5	3.0	R35	—
6-0/3-10		71-1/2	45-1/2	18-7/16	17-5/16	2.2	13.5	2.5	3.0	R35	—
6-0/4-0		71-1/2	47-1/2	18-7/16	18-5/16	2.3	14.2	2.5	3.0	R35	—
6-0/4-3		71-1/2	51-1/2	18-7/16	20-5/16	2.6	15.6	2.5	3.0	R35	—
6-0/4-6		71-1/2	53-1/2	18-7/16	21-5/16	2.7	16.4	2.5	3.0	R35	—
6-0/5-0		71-1/2	59-1/2	18-7/16	24-5/16	3.1	18.5	2.5	3.0	R35	—
6-0/5-2		71-1/2	61-1/2	18-7/16	25-5/16	3.2	19.2	2.5	3.0	R35	—
6-0/5-6		71-1/2	65-1/2	18-7/16	27-5/16	3.5	20.7	2.5	3.0	R30	—
6-0/6-0		71-1/2	71-1/2	18-7/16	30-5/16	3.8	22.8	2.5	3.0	R30	—
6-0/6-6		71-1/2	77-1/2	18-7/16	33-5/16	4.2	25.0	2.5	3.0	R20	—
7-0/3-0		83-1/2	35-1/2	22-7/16	12-5/16	1.9	12.2	2.5	3.0	R35	—
7-0/3-2		83-1/2	37-1/2	22-7/16	13-5/16	2.0	13.1	2.5	3.0	R35	—
7-0/3-6		83-1/2	41-1/2	22-7/16	15-5/16	2.3	14.8	2.5	3.0	R35	—
7-0/3-10		83-1/2	45-1/2	22-7/16	17-5/16	2.7	16.6	2.5	3.0	R35	—
7-0/4-0		83-1/2	47-1/2	22-7/16	18-5/16	2.8	17.5	2.5	3.0	R35	—
7-0/4-3		83-1/2	51-1/2	22-7/16	20-5/16	3.1	19.3	2.5	3.0	R35	—
7-0/4-6		83-1/2	53-1/2	22-7/16	21-5/16	3.3	20.1	2.5	3.0	R35	—
7-0/5-0		83-1/2	59-1/2	22-7/16	24-5/16	3.7	22.8	2.5	3.0	R35	—
7-0/5-2		83-1/2	61-1/2	22-7/16	25-5/16	3.9	23.7	2.5	3.0	R35	—
7-0/5-6		83-1/2	65-1/2	22-7/16	27-5/16	4.2	25.5	2.5	3.0	R30	—
7-0/6-0		83-1/2	71-1/2	22-7/16	30-5/16	4.7	28.1	2.5	3.0	R30	—
7-0/6-6	E1	83-1/2	77-1/2	22-7/16	33-5/16	5.1	30.8	2.5	3.0	R20	—
7-6/3-0		89-1/2	35-1/2	24-7/16	12-5/16	2.0	13.3	2.5	3.0	R35	—
7-6/3-2		89-1/2	37-1/2	24-7/16	13-5/16	2.2	14.3	2.5	3.0	R35	—
7-6/3-6		89-1/2	41-1/2	24-7/16	15-5/16	2.6	16.2	2.5	3.0	R35	—
7-6/3-10		89-1/2	45-1/2	24-7/16	17-5/16	2.9	18.2	2.5	3.0	R35	—
7-6/4-0		89-1/2	47-1/2	24-7/16	18-5/16	3.1	19.1	2.5	3.0	R35	—
7-6/4-3		89-1/2	51-1/2	24-7/16	20-5/16	3.4	21.1	2.5	3.0	R35	—
7-6/4-6		89-1/2	53-1/2	24-7/16	21-5/16	3.6	22.0	2.5	3.0	R35	—
7-6/5-0		89-1/2	59-1/2	24-7/16	24-5/16	4.1	24.9	2.5	3.0	R35	—
7-6/5-2		89-1/2	61-1/2	24-7/16	25-5/16	4.3	25.9	2.5	3.0	R35	—
7-6/5-6		89-1/2	65-1/2	24-7/16	27-5/16	4.6	27.9	2.5	3.0	R30	—
7-6/6-0	E1	89-1/2	71-1/2	24-7/16	30-5/16	5.1	30.8	2.5	3.0	R30	—
7-6/6-6	E1	89-1/2	77-1/2	24-7/16	33-5/16	5.6	33.7	2.5	3.0	R20	—
8-0/3-0		95-1/2	35-1/2	26-7/16	12-5/16	2.2	14.5	2.5	3.0	R35	—
8-0/3-2		95-1/2	37-1/2	26-7/16	13-5/16	2.4	15.5	2.5	3.0	R35	—
8-0/3-6		95-1/2	41-1/2	26-7/16	15-5/16	2.8	17.6	2.5	3.0	R35	—
8-0/3-10		95-1/2	45-1/2	26-7/16	17-5/16	3.1	19.7	2.5	3.0	R35	—
8-0/4-0		95-1/2	47-1/2	26-7/16	18-5/16	3.3	20.8	2.5	3.0	R35	—
8-0/4-3		95-1/2	51-1/2	26-7/16	20-5/16	3.7	22.9	2.5	3.0	R35	—
8-0/4-6		95-1/2	53-1/2	26-7/16	21-5/16	3.9	23.9	2.5	3.0	R35	—
8-0/5-0		95-1/2	59-1/2	26-7/16	24-5/16	4.4	27.1	2.5	3.0	R35	—
8-0/5-2		95-1/2	61-1/2	26-7/16	25-5/16	4.6	28.1	2.5	3.0	R35	—
8-0/5-6	E1	95-1/2	65-1/2	26-7/16	27-5/16	5.0	30.2	2.5	3.0	R30	—
9-0/3-0		107-1/2	35-1/2	30-7/16	12-5/16	2.6	16.8	2.5	3.0	R35	—
9-0/3-2		107-1/2	37-1/2	30-7/16	13-5/16	2.8	18.0	2.5	3.0	R35	—
9-0/3-6		107-1/2	41-1/2	30-7/16	15-5/16	3.2	20.4	2.5	3.0	R35	—
9-0/3-10		107-1/2	45-1/2	30-7/16	17-5/16	3.6	22.9	2.5	3.0	R35	—
9-0/4-0		107-1/2	47-1/2	30-7/16	18-5/16	3.8	24.1	2.5	3.0	R35	—
9-0/4-3		107-1/2	51-1/2	30-7/16	20-5/16	4.3	26.5	2.5	3.0	R20	—
9-0/4-6		107-1/2	53-1/2	30-7/16	21-5/16	4.5	27.7	2.5	3.0	R20	—
9-0/5-0	E1	107-1/2	59-1/2	30-7/16	24-5/16	5.1	31.4	2.5	3.0	R20	—
9-0/5-2	E1	107-1/2	61-1/2	30-7/16	25-5/16	5.3	32.6	2.5	3.0	R20	—

**Egress Notes:**  
 Check all applicable local codes for emergency egress requirements.

E = Window meets minimum clear opening of 24" height, 20" width, and 5.7 ft<sup>2</sup>.

E1 = Window meets minimum clear opening of 24" height, 20" width, and 5.0 ft<sup>2</sup>.

To convert areas to square meters (m<sup>2</sup>), multiply square feet by 0.0929.

(-) = Not Available

(1) Maximum performance when glazed with the appropriate glass thickness.



# 250 Series Double-Hung

## Design Data

1-Wide Vent Units — Cottage Sash											
Unit	Egress	Frame (Inches)		Clear Opening (Vent Units Only) (Inches)			Visible Glass Ft <sup>2</sup>	Glass Thickness (mm)		Performance Class & Grade <sup>(1)</sup>	
		Width	Height	Width	Height	Ft <sup>2</sup>		Annealed	Tempered	Standard	Upgrade
2-0/3-0		23-1/2	35-1/2	18-7/16	9-3/8	1.2	3.3	2.5	3.0	R35	R50
2-0/3-2		23-1/2	37-1/2	18-7/16	10-3/16	1.3	3.5	2.5	3.0	R35	R50
2-0/3-6		23-1/2	41-1/2	18-7/16	11-3/4	1.5	4.0	2.5	3.0	R35	R50
2-0/3-10		23-1/2	45-1/2	18-7/16	13-3/8	1.7	4.5	2.5	3.0	R35	R50
2-0/4-0		23-1/2	47-1/2	18-7/16	14-3/16	1.8	4.7	2.5	3.0	R35	R50
2-0/4-4		23-1/2	51-1/2	18-7/16	15-3/4	2.0	5.2	2.5	3.0	R35	R50
2-0/4-6		23-1/2	53-1/2	18-7/16	16-9/16	2.1	5.5	2.5	3.0	R35	R50
2-0/5-0		23-1/2	59-1/2	18-7/16	18-15/16	2.4	6.2	2.5	3.0	R35	R50
2-0/5-2		23-1/2	61-1/2	18-7/16	19-3/4	2.5	6.4	2.5	3.0	R35	R50
2-0/5-6		23-1/2	65-1/2	18-7/16	21-3/8	2.7	6.9	2.5	3.0	R30	R50
2-4/3-0		27-1/2	35-1/2	22-7/16	9-3/8	1.4	4.1	2.5	3.0	R35	R50
2-4/3-2		27-1/2	37-1/2	22-7/16	10-3/16	1.5	4.4	2.5	3.0	R35	R50
2-4/3-6		27-1/2	41-1/2	22-7/16	11-3/4	1.8	4.9	2.5	3.0	R35	R50
2-4/3-10		27-1/2	45-1/2	22-7/16	13-3/8	2.0	5.5	2.5	3.0	R35	R50
2-4/4-0		27-1/2	47-1/2	22-7/16	14-3/16	2.2	5.8	2.5	3.0	R35	R50
2-4/4-4		27-1/2	51-1/2	22-7/16	15-3/4	2.4	6.4	2.5	3.0	R35	R50
2-4/4-6		27-1/2	53-1/2	22-7/16	16-9/16	2.5	6.7	2.5	3.0	R35	R50
2-4/5-0		27-1/2	59-1/2	22-7/16	18-15/16	2.9	7.6	2.5	3.0	R35	R50
2-4/5-2		27-1/2	61-1/2	22-7/16	19-3/4	3.0	7.9	2.5	3.0	R35	R50
2-4/5-6		27-1/2	65-1/2	22-7/16	21-3/8	3.3	8.5	2.5	3.0	R30	R50
2-6/3-0		29-1/2	35-1/2	24-7/16	9-3/8	1.5	4.4	2.5	3.0	R35	R50
2-6/3-2		29-1/2	37-1/2	24-7/16	10-3/16	1.7	4.8	2.5	3.0	R35	R50
2-6/3-6		29-1/2	41-1/2	24-7/16	11-3/4	2.0	5.4	2.5	3.0	R35	R50
2-6/3-10		29-1/2	45-1/2	24-7/16	13-3/8	2.2	6.1	2.5	3.0	R35	R50
2-6/4-0		29-1/2	47-1/2	24-7/16	14-3/16	2.4	6.4	2.5	3.0	R35	R50
2-6/4-4		29-1/2	51-1/2	24-7/16	15-3/4	2.6	7.0	2.5	3.0	R35	R50
2-6/4-6		29-1/2	53-1/2	24-7/16	16-9/16	2.8	7.3	2.5	3.0	R35	R50
2-6/5-0		29-1/2	59-1/2	24-7/16	18-15/16	3.2	8.3	2.5	3.0	R35	R50
2-6/5-2		29-1/2	61-1/2	24-7/16	19-3/4	3.3	8.6	2.5	3.0	R35	R50
2-6/5-6		29-1/2	65-1/2	24-7/16	21-3/8	3.6	9.3	2.5	3.0	R30	R50
2-8/3-0		31-1/2	35-1/2	26-7/16	9-3/8	1.7	4.8	2.5	3.0	R35	R50
2-8/3-2		31-1/2	37-1/2	26-7/16	10-3/16	1.8	5.2	2.5	3.0	R35	R50
2-8/3-6		31-1/2	41-1/2	26-7/16	11-3/4	2.1	5.9	2.5	3.0	R35	R50
2-8/3-10		31-1/2	45-1/2	26-7/16	13-3/8	2.4	6.6	2.5	3.0	R35	R50
2-8/4-0		31-1/2	47-1/2	26-7/16	14-3/16	2.6	6.9	2.5	3.0	R35	R50
2-8/4-4		31-1/2	51-1/2	26-7/16	15-3/4	2.9	7.6	2.5	3.0	R35	R50
2-8/4-6		31-1/2	53-1/2	26-7/16	16-9/16	3.0	8.0	2.5	3.0	R35	R50
2-8/5-0		31-1/2	59-1/2	26-7/16	18-15/16	3.4	9.0	2.5	3.0	R35	R50
2-8/5-2		31-1/2	61-1/2	26-7/16	19-3/4	3.6	9.4	2.5	3.0	R35	R50
2-8/5-6		31-1/2	65-1/2	26-7/16	21-3/8	3.9	10.1	2.5	3.0	R30	R50
3-0/3-0		35-1/2	35-1/2	30-7/16	9-3/8	1.9	5.6	2.5	3.0	R35	R50
3-0/3-2		35-1/2	37-1/2	30-7/16	10-3/16	2.1	6.0	2.5	3.0	R35	R50
3-0/3-6		35-1/2	41-1/2	30-7/16	11-3/4	2.4	6.8	2.5	3.0	R35	R50
3-0/3-10		35-1/2	45-1/2	30-7/16	13-3/8	2.8	7.6	2.5	3.0	R35	R50
3-0/4-0		35-1/2	47-1/2	30-7/16	14-3/16	3.0	8.0	2.5	3.0	R35	R50
3-0/4-4		35-1/2	51-1/2	30-7/16	15-3/4	3.3	8.8	2.5	3.0	R35	R50
3-0/4-6		35-1/2	53-1/2	30-7/16	16-9/16	3.5	9.2	2.5	3.0	R35	R50
3-0/5-0		35-1/2	59-1/2	30-7/16	18-15/16	4.0	10.5	2.5	3.0	R35	R50
3-0/5-2		35-1/2	61-1/2	30-7/16	19-3/4	4.1	10.9	2.5	3.0	R35	R50
3-0/5-6		35-1/2	65-1/2	30-7/16	21-3/8	4.5	11.7	2.5	3.0	R30	R50

(1) Maximum performance when glazed with the appropriate glass thickness.



# 250 Series Double-Hung

## Design Data

1-Wide Vent Units — Cottage Sash											
Unit	Egress	Frame (Inches)		Clear Opening (Vent Units Only) (Inches)			Visible Glass Ft <sup>2</sup>	Glass Thickness (mm)		Performance Class & Grade <sup>1</sup>	
		Width	Height	Width	Height	Ft <sup>2</sup>		Annealed	Tempered	Standard	Upgrade
3-2/3-0		37-1/2	35-1/2	32-7/16	9-3/8	2.1	6.0	2.5	3.0	R30	R50
3-2/3-2		37-1/2	37-1/2	32-7/16	10-3/16	2.2	6.4	2.5	3.0	R30	R50
3-2/3-6		37-1/2	41-1/2	32-7/16	11-3/4	2.6	7.3	2.5	3.0	R30	R50
3-2/3-10		37-1/2	45-1/2	32-7/16	13-3/8	3.0	8.1	2.5	3.0	R30	R50
3-2/4-0		37-1/2	47-1/2	32-7/16	14-3/16	3.1	8.6	2.5	3.0	R30	R50
3-2/4-4		37-1/2	51-1/2	32-7/16	15-3/4	3.5	9.4	2.5	3.0	R30	R50
3-2/4-6		37-1/2	53-1/2	32-7/16	16-9/16	3.7	9.9	2.5	3.0	R30	R50
3-2/5-0		37-1/2	59-1/2	32-7/16	18-15/16	4.2	11.2	2.5	3.0	R30	R50
3-2/5-2		37-1/2	61-1/2	32-7/16	19-3/4	4.4	11.6	2.5	3.0	R30	R50
3-2/5-6		37-1/2	65-1/2	32-7/16	21-3/8	4.8	12.5	2.5	3.0	R30	R50
3-6/3-0		41-1/2	35-1/2	36-7/16	9-3/8	2.3	6.7	2.5	3.0	R30	R50
3-6/3-2		41-1/2	37-1/2	36-7/16	10-3/16	2.5	7.2	2.5	3.0	R30	R50
3-6/3-6		41-1/2	41-1/2	36-7/16	11-3/4	2.9	8.2	2.5	3.0	R30	R50
3-6/3-10		41-1/2	45-1/2	36-7/16	13-3/8	3.3	9.2	2.5	3.0	R30	R50
3-6/4-0		41-1/2	47-1/2	36-7/16	14-3/16	3.5	9.7	2.5	3.0	R30	R50
3-6/4-4		41-1/2	51-1/2	36-7/16	15-3/4	3.9	10.6	2.5	3.0	R30	R50
3-6/4-6		41-1/2	53-1/2	36-7/16	16-9/16	4.1	11.1	2.5	3.0	R30	R50
3-6/5-0		41-1/2	59-1/2	36-7/16	18-15/16	4.8	12.6	2.5	3.0	R30	R50
3-6/5-2		41-1/2	61-1/2	36-7/16	19-3/4	5.0	13.1	2.5	3.0	R30	R50
3-6/5-6		41-1/2	65-1/2	36-7/16	21-3/8	5.4	14.1	2.5	3.0	R20	R50
4-0/3-0		47-1/2	35-1/2	42-7/16	9-3/8	2.7	7.9	2.5	3.0	R30	R50
4-0/3-2		47-1/2	37-1/2	42-7/16	10-3/16	3.0	8.5	2.5	3.0	R30	R50
4-0/3-6		47-1/2	41-1/2	42-7/16	11-3/4	3.4	9.6	2.5	3.0	R30	R50
4-0/3-10		47-1/2	45-1/2	42-7/16	13-3/8	3.9	10.7	2.5	3.0	R30	R50
4-0/4-0		47-1/2	47-1/2	42-7/16	14-3/16	4.1	11.3	2.5	3.0	R30	R50
4-0/4-4		47-1/2	51-1/2	42-7/16	15-3/4	4.6	12.5	2.5	3.0	R30	R50
4-0/4-6		47-1/2	53-1/2	42-7/16	16-9/16	4.8	13.0	2.5	3.0	R30	R50
4-0/5-0		47-1/2	59-1/2	42-7/16	18-15/16	5.5	14.8	2.5	3.0	R30	R50
4-0/5-2		47-1/2	61-1/2	42-7/16	19-3/4	5.8	15.3	2.5	3.0	R30	R50
4-0/5-6		47-1/2	65-1/2	42-7/16	21-3/8	6.3	16.5	2.5	3.0	R20	R50
4-6/3-0		53-1/2	35-1/2	48-7/16	9-3/8	3.1	9.0	2.5	3.0	R20	—
4-6/3-2		53-1/2	37-1/2	48-7/16	10-3/16	3.4	9.7	2.5	3.0	R20	—
4-6/3-6		53-1/2	41-1/2	48-7/16	11-3/4	3.9	11.0	2.5	3.0	R20	—
4-6/3-10		53-1/2	45-1/2	48-7/16	13-3/8	4.5	12.3	2.5	3.0	R20	—
4-6/4-0		53-1/2	47-1/2	48-7/16	14-3/16	4.7	13.0	2.5	3.0	R20	—
4-6/4-4		53-1/2	51-1/2	48-7/16	15-3/4	5.3	14.3	2.5	3.0	R20	—
4-6/4-6		53-1/2	53-1/2	48-7/16	16-9/16	5.5	14.9	2.5	3.0	R20	—
4-6/5-0		53-1/2	59-1/2	48-7/16	18-15/16	6.3	16.9	2.5	3.0	R20	—
4-6/5-2		53-1/2	61-1/2	48-7/16	19-3/4	6.6	17.6	2.5	3.0	R20	—
4-6/5-6		53-1/2	65-1/2	48-7/16	21-3/8	7.1	18.9	2.5	3.0	R20	—

(-) = Not Available

(1) Maximum performance when glazed with the appropriate glass thickness.



# 250 Series Double-Hung

## Design Data

2-Wide Vent Unit Composites with Integral Mullion — Cottage Sash											
Unit	Egress	Frame (Inches)		Clear Opening (Vent Units Only) (Inches)			Visible Glass Ft <sup>2</sup>	Glass Thickness (mm)		Performance Class & Grade <sup>(1)</sup>	
		Width	Height	Width	Height	Ft <sup>2</sup>		Annealed	Tempered	Standard	Upgrade
4-0/3-0		47-1/2	35-1/2	18-7/16	9-3/8	1.2	6.6	2.5	3.0	R35	R50
4-0/3-2		47-1/2	37-1/2	18-7/16	10-3/16	1.3	7.1	2.5	3.0	R35	R50
4-0/3-6		47-1/2	41-1/2	18-7/16	11-3/4	1.5	8.0	2.5	3.0	R35	R50
4-0/3-10		47-1/2	45-1/2	18-7/16	13-3/8	1.7	9.0	2.5	3.0	R35	R50
4-0/4-0		47-1/2	47-1/2	18-7/16	14-3/16	1.8	9.5	2.5	3.0	R35	R50
4-0/4-4		47-1/2	51-1/2	18-7/16	15-3/4	2.0	10.4	2.5	3.0	R35	R50
4-0/4-6		47-1/2	53-1/2	18-7/16	16-9/16	2.1	10.9	2.5	3.0	R35	R50
4-0/5-0		47-1/2	59-1/2	18-7/16	18-15/16	2.4	12.3	2.5	3.0	R35	R50
4-0/5-2		47-1/2	61-1/2	18-7/16	19-3/4	2.5	12.8	2.5	3.0	R35	R50
4-0/5-6		47-1/2	65-1/2	18-7/16	21-3/8	2.7	13.8	2.5	3.0	R30	R50
4-8/3-0		55-1/2	35-1/2	22-7/16	9-3/8	1.4	8.1	2.5	3.0	R35	R50
4-8/3-2		55-1/2	37-1/2	22-7/16	10-3/16	1.5	8.7	2.5	3.0	R35	R50
4-8/3-6		55-1/2	41-1/2	22-7/16	11-3/4	1.8	9.9	2.5	3.0	R35	R50
4-8/3-10		55-1/2	45-1/2	22-7/16	13-3/8	2.0	11.1	2.5	3.0	R35	R50
4-8/4-0		55-1/2	47-1/2	22-7/16	14-3/16	2.2	11.7	2.5	3.0	R35	R50
4-8/4-4		55-1/2	51-1/2	22-7/16	15-3/4	2.4	12.8	2.5	3.0	R35	R50
4-8/4-6		55-1/2	53-1/2	22-7/16	16-9/16	2.5	13.4	2.5	3.0	R35	R50
4-8/5-0		55-1/2	59-1/2	22-7/16	18-15/16	2.9	15.2	2.5	3.0	R35	R50
4-8/5-2		55-1/2	61-1/2	22-7/16	19-3/4	3.0	15.8	2.5	3.0	R35	R50
4-8/5-6		55-1/2	65-1/2	22-7/16	21-3/8	3.3	17.0	2.5	3.0	R30	R50
5-0/3-0		59-1/2	35-1/2	24-7/16	9-3/8	1.5	8.9	2.5	3.0	R35	R50
5-0/3-2		59-1/2	37-1/2	24-7/16	10-3/16	1.7	9.5	2.5	3.0	R35	R50
5-0/3-6		59-1/2	41-1/2	24-7/16	11-3/4	2.0	10.8	2.5	3.0	R35	R50
5-0/3-10		59-1/2	45-1/2	24-7/16	13-3/8	2.2	12.1	2.5	3.0	R35	R50
5-0/4-0		59-1/2	47-1/2	24-7/16	14-3/16	2.4	12.8	2.5	3.0	R35	R50
4-1/4-4		59-1/2	51-1/2	24-7/16	15-3/4	2.6	14.0	2.5	3.0	R35	R50
5-0/4-6		59-1/2	53-1/2	24-7/16	16-9/16	2.8	14.7	2.5	3.0	R35	R50
5-0/5-0		59-1/2	59-1/2	24-7/16	18-15/16	3.2	16.6	2.5	3.0	R35	R50
5-0/5-2		59-1/2	61-1/2	24-7/16	19-3/4	3.3	17.3	2.5	3.0	R35	R50
5-0/5-6		59-1/2	65-1/2	24-7/16	21-3/8	3.6	18.6	2.5	3.0	R30	R50
5-4/3-0		63-1/2	35-1/2	26-7/16	9-3/8	1.7	9.6	2.5	3.0	R35	R50
5-4/3-2		63-1/2	37-1/2	26-7/16	10-3/16	1.8	10.3	2.5	3.0	R35	R50
5-4/3-6		63-1/2	41-1/2	26-7/16	11-3/4	2.1	11.7	2.5	3.0	R35	R50
5-4/3-10		63-1/2	45-1/2	26-7/16	13-3/8	2.4	13.2	2.5	3.0	R35	R50
5-4/4-0		63-1/2	47-1/2	26-7/16	14-3/16	2.6	13.9	2.5	3.0	R35	R50
5-4/4-4		63-1/2	51-1/2	26-7/16	15-3/4	2.9	15.3	2.5	3.0	R35	R50
5-4/4-6		63-1/2	53-1/2	26-7/16	16-9/16	3.0	16.0	2.5	3.0	R35	R50
5-4/5-0		63-1/2	59-1/2	26-7/16	18-15/16	3.4	18.1	2.5	3.0	R35	R50
5-4/5-2		63-1/2	61-1/2	26-7/16	19-3/4	3.6	18.8	2.5	3.0	R35	R50
5-4/5-6		63-1/2	65-1/2	26-7/16	21-3/8	3.9	20.2	2.5	3.0	R30	R50
6-0/3-0		71-1/2	35-1/2	30-7/16	9-3/8	1.9	11.2	2.5	3.0	R35	R50
6-0/3-2		71-1/2	37-1/2	30-7/16	10-3/16	2.1	12.0	2.5	3.0	R35	R50
6-0/3-6		71-1/2	41-1/2	30-7/16	11-3/4	2.4	13.6	2.5	3.0	R35	R50
6-0/3-10		71-1/2	45-1/2	30-7/16	13-3/8	2.8	15.2	2.5	3.0	R35	R50
6-0/4-0		71-1/2	47-1/2	30-7/16	14-3/16	3.0	16.0	2.5	3.0	R35	R50
6-0/4-4		71-1/2	51-1/2	30-7/16	15-3/4	3.3	17.7	2.5	3.0	R35	R50
6-0/4-6		71-1/2	53-1/2	30-7/16	16-9/16	3.5	18.5	2.5	3.0	R35	R50
6-0/5-0		71-1/2	59-1/2	30-7/16	18-15/16	4.0	20.9	2.5	3.0	R35	R50
6-0/5-2		71-1/2	61-1/2	30-7/16	19-3/4	4.1	21.7	2.5	3.0	R35	R50
6-0/5-6		71-1/2	65-1/2	30-7/16	21-3/8	4.5	23.4	2.5	3.0	R30	R50

(-) = Not Available

(1) Maximum performance when glazed with the appropriate glass thickness.



# 250 Series Double-Hung

## Design Data

2-Wide Vent Unit Composites with Integral Mullion – Cottage Sash											
Unit	Egress	Frame (Inches)		Clear Opening (Vent Units Only) (Inches)			Visible Glass Ft <sup>2</sup>	Glass Thickness (mm)		Performance Class & Grade <sup>(1)</sup>	
		Width	Height	Width	Height	Ft <sup>2</sup>		Annealed	Tempered	Standard	Upgrade
6-4/3-0		75-1/2	35-1/2	32-7/16	9-3/8	2.1	11.9	2.5	3.0	R30	—
6-4/3-2		75-1/2	37-1/2	32-7/16	10-3/16	2.2	12.8	2.5	3.0	R30	—
6-4/3-6		75-1/2	41-1/2	32-7/16	11-3/4	2.6	14.5	2.5	3.0	R30	—
6-4/3-10		75-1/2	45-1/2	32-7/16	13-3/8	3.0	16.3	2.5	3.0	R30	—
6-4/4-0		75-1/2	47-1/2	32-7/16	14-3/16	3.1	17.1	2.5	3.0	R30	—
6-4/4-4		75-1/2	51-1/2	32-7/16	15-3/4	3.5	18.9	2.5	3.0	R30	—
6-4/4-6		75-1/2	53-1/2	32-7/16	16-9/16	3.7	19.7	2.5	3.0	R30	—
6-4/5-0		75-1/2	59-1/2	32-7/16	18-15/16	4.2	22.4	2.5	3.0	R30	—
6-4/5-2		75-1/2	61-1/2	32-7/16	19-3/4	4.4	23.2	2.5	3.0	R30	—
6-4/5-6		75-1/2	65-1/2	32-7/16	21-3/8	4.8	25.0	2.5	3.0	R30	—
7-0/3-0		83-1/2	35-1/2	42-7/16	9-3/8	2.3	13.5	2.5	3.0	R30	—
7-0/3-2		83-1/2	37-1/2	42-7/16	10-3/16	2.5	14.4	2.5	3.0	R30	—
7-0/3-6		83-1/2	41-1/2	42-7/16	11-3/4	2.9	16.4	2.5	3.0	R30	—
7-0/3-10		83-1/2	45-1/2	42-7/16	13-3/8	3.3	18.4	2.5	3.0	R30	—
7-0/4-0		83-1/2	47-1/2	42-7/16	14-3/16	3.5	19.3	2.5	3.0	R30	—
7-0/4-4		83-1/2	51-1/2	42-7/16	15-3/4	3.9	21.3	2.5	3.0	R30	—
7-0/4-6		83-1/2	53-1/2	42-7/16	16-9/16	4.1	22.3	2.5	3.0	R30	—
7-0/5-0		83-1/2	59-1/2	42-7/16	18-15/16	4.8	25.2	2.5	3.0	R30	—
7-0/5-2		83-1/2	61-1/2	42-7/16	19-3/4	5.0	26.2	2.5	3.0	R30	—
7-0/5-6		83-1/2	65-1/2	42-7/16	21-3/8	5.4	28.2	2.5	3.0	R30	—
8-0/3-0		95-1/2	35-1/2	48-7/16	9-3/8	2.7	15.8	2.5	3.0	R30	—
8-0/3-2		95-1/2	37-1/2	48-7/16	10-3/16	3.0	16.9	2.5	3.0	R30	—
8-0/3-6		95-1/2	41-1/2	48-7/16	11-3/4	3.4	19.2	2.5	3.0	R30	—
8-0/3-10		95-1/2	45-1/2	48-7/16	13-3/8	3.9	21.5	2.5	3.0	R30	—
8-0/4-0		95-1/2	47-1/2	48-7/16	14-3/16	4.1	22.6	2.5	3.0	R30	—
8-0/4-4		95-1/2	51-1/2	48-7/16	15-3/4	4.6	24.9	2.5	3.0	R30	—
8-0/4-6		95-1/2	53-1/2	48-7/16	16-9/16	4.8	26.1	2.5	3.0	R30	—
8-0/5-0		95-1/2	59-1/2	48-7/16	18-15/16	5.5	29.5	2.5	3.0	R30	—
8-0/5-2		95-1/2	61-1/2	48-7/16	19-3/4	5.8	30.7	2.5	3.0	R30	—
8-0/5-6		95-1/2	65-1/2	48-7/16	21-3/8	6.3	32.9	2.5	3.0	R30	—

(—) = Not Available

(1) Maximum performance when glazed with the appropriate glass thickness.



# 250 Series Double-Hung

## Design Data

3-Wide Vent Unit Composites with Integral Mullion — Cottage Sash											
Unit	Egress	Frame (Inches)		Clear Opening (Vent Units Only) (Inches)			Visible Glass Ft <sup>2</sup>	Glass Thickness (mm)		Performance Class & Grade <sup>(1)</sup>	
		Width	Height	Width	Height	Ft <sup>2</sup>		Annealed	Tempered	Standard	Upgrade
6-0/3-0		71-1/2	35-1/2	18-7/16	9-3/8	1.2	9.9	2.5	3.0	R35	—
6-0/3-2		71-1/2	37-1/2	18-7/16	10-3/16	1.3	10.6	2.5	3.0	R35	—
6-0/3-6		71-1/2	41-1/2	18-7/16	11-3/4	1.5	12.0	2.5	3.0	R35	—
6-0/3-10		71-1/2	45-1/2	18-7/16	13-3/8	1.7	13.5	2.5	3.0	R35	—
6-0/4-0		71-1/2	47-1/2	18-7/16	14-3/16	1.8	14.2	2.5	3.0	R35	—
6-0/4-3		71-1/2	51-1/2	18-7/16	15-3/4	2.0	15.6	2.5	3.0	R35	—
6-0/4-6		71-1/2	53-1/2	18-7/16	16-9/16	2.1	16.4	2.5	3.0	R35	—
6-0/5-0		71-1/2	59-1/2	18-7/16	18-15/16	2.4	18.5	2.5	3.0	R35	—
6-0/5-2		71-1/2	61-1/2	18-7/16	19-3/4	2.5	19.2	2.5	3.0	R35	—
6-0/5-6		71-1/2	65-1/2	18-7/16	21-3/8	2.7	20.7	2.5	3.0	R30	—
7-0/3-0		83-1/2	35-1/2	22-7/16	9-3/8	1.4	12.2	2.5	3.0	R35	—
7-0/3-2		83-1/2	37-1/2	22-7/16	10-3/16	1.5	13.1	2.5	3.0	R35	—
7-0/3-6		83-1/2	41-1/2	22-7/16	11-3/4	1.8	14.8	2.5	3.0	R35	—
7-0/3-10		83-1/2	45-1/2	22-7/16	13-3/8	2.0	16.6	2.5	3.0	R35	—
7-0/4-0		83-1/2	47-1/2	22-7/16	14-3/16	2.2	17.5	2.5	3.0	R35	—
7-0/4-3		83-1/2	51-1/2	22-7/16	15-3/4	2.4	19.3	2.5	3.0	R35	—
7-0/4-6		83-1/2	53-1/2	22-7/16	16-9/16	2.5	20.1	2.5	3.0	R35	—
7-0/5-0		83-1/2	59-1/2	22-7/16	18-15/16	2.9	22.8	2.5	3.0	R35	—
7-0/5-2		83-1/2	61-1/2	22-7/16	19-3/4	3.0	23.7	2.5	3.0	R35	—
7-0/5-6		83-1/2	65-1/2	22-7/16	21-3/8	3.3	25.5	2.5	3.0	R30	—
7-6/3-0		89-1/2	35-1/2	24-7/16	9-3/8	1.5	13.3	2.5	3.0	R35	—
7-6/3-2		89-1/2	37-1/2	24-7/16	10-3/16	1.7	14.3	2.5	3.0	R35	—
7-6/3-6		89-1/2	41-1/2	24-7/16	11-3/4	2.0	16.2	2.5	3.0	R35	—
7-6/3-10		89-1/2	45-1/2	24-7/16	13-3/8	2.2	18.2	2.5	3.0	R35	—
7-6/4-0		89-1/2	47-1/2	24-7/16	14-3/16	2.4	19.1	2.5	3.0	R35	—
7-6/4-3		89-1/2	51-1/2	24-7/16	15-3/4	2.6	21.1	2.5	3.0	R35	—
7-6/4-6		89-1/2	53-1/2	24-7/16	16-9/16	2.8	22.0	2.5	3.0	R35	—
7-6/5-0		89-1/2	59-1/2	24-7/16	18-15/16	3.2	24.9	2.5	3.0	R35	—
7-6/5-2		89-1/2	61-1/2	24-7/16	19-3/4	3.3	25.9	2.5	3.0	R35	—
7-6/5-6		89-1/2	65-1/2	24-7/16	21-3/8	3.6	27.9	2.5	3.0	R30	—
8-0/3-0		95-1/2	35-1/2	26-7/16	9-3/8	1.7	14.5	2.5	3.0	R35	—
8-0/3-2		95-1/2	37-1/2	26-7/16	10-3/16	1.8	15.5	2.5	3.0	R35	—
8-0/3-6		95-1/2	41-1/2	26-7/16	11-3/4	2.1	17.6	2.5	3.0	R35	—
8-0/3-10		95-1/2	45-1/2	26-7/16	13-3/8	2.4	19.7	2.5	3.0	R35	—
8-0/4-0		95-1/2	47-1/2	26-7/16	14-3/16	2.6	20.8	2.5	3.0	R35	—
8-0/4-3		95-1/2	51-1/2	26-7/16	15-3/4	2.9	22.9	2.5	3.0	R35	—
8-0/4-6		95-1/2	53-1/2	26-7/16	16-9/16	3.0	23.9	2.5	3.0	R35	—
8-0/5-0		95-1/2	59-1/2	26-7/16	18-15/16	3.4	27.1	2.5	3.0	R35	—
8-0/5-2		95-1/2	61-1/2	26-7/16	19-3/4	3.6	28.1	2.5	3.0	R35	—
8-0/5-6		95-1/2	65-1/2	26-7/16	21-3/8	3.9	30.2	2.5	3.0	R30	—
9-0/3-0		107-1/2	35-1/2	30-7/16	9-3/8	1.9	16.8	2.5	3.0	R35	—
9-0/3-2		107-1/2	37-1/2	30-7/16	10-3/16	2.1	18.0	2.5	3.0	R35	—
9-0/3-6		107-1/2	41-1/2	30-7/16	11-3/4	2.4	20.4	2.5	3.0	R35	—
9-0/3-10		107-1/2	45-1/2	30-7/16	13-3/8	2.8	22.9	2.5	3.0	R35	—
9-0/4-0		107-1/2	47-1/2	30-7/16	14-3/16	3.0	24.1	2.5	3.0	R35	—
9-0/4-3		107-1/2	51-1/2	30-7/16	15-3/4	3.3	26.5	2.5	3.0	R35	—
9-0/4-6		107-1/2	53-1/2	30-7/16	16-9/16	3.5	27.7	2.5	3.0	R35	—
9-0/5-0		107-1/2	59-1/2	30-7/16	18-15/16	4.0	31.4	2.5	3.0	R35	—
9-0/5-2		107-1/2	61-1/2	30-7/16	19-3/4	4.1	32.6	2.5	3.0	R35	—

(—) = Not Available

(1) Maximum performance when glazed with the appropriate glass thickness.



# 250 Series Double-Hung

## Design Data

1-Wide Vent Units – Contemporary Sash											
Unit	Egress	Frame (Inches)		Clear Opening (Vent Units Only) (Inches)			Visible Glass Ft <sup>2</sup>	Glass Thickness (mm)		Performance Class & Grade <sup>(1)</sup>	
		Width	Height	Width	Height	Ft <sup>2</sup>		Annealed	Tempered	Standard	Upgrade
2-0/3-0		23-1/2	35-1/2	18-7/16	9-1/4	1.1	3.3	2.5	3.0	R35	R50
2-0/3-2		23-1/2	37-1/2	18-7/16	10-1/16	1.2	3.5	2.5	3.0	R35	R50
2-0/3-6		23-1/2	41-1/2	18-7/16	11-11/16	1.4	4.0	2.5	3.0	R35	R50
2-0/3-10		23-1/2	45-1/2	18-7/16	13-1/4	1.7	4.5	2.5	3.0	R35	R50
2-0/4-0		23-1/2	47-1/2	18-7/16	14-1/16	1.8	4.7	2.5	3.0	R35	R50
2-0/4-4		23-1/2	51-1/2	18-7/16	15-11/16	2.0	5.2	2.5	3.0	R35	R50
2-0/4-6		23-1/2	53-1/2	18-7/16	16-7/16	2.1	5.5	2.5	3.0	R35	R50
2-0/5-0		23-1/2	59-1/2	18-7/16	18-7/8	2.4	6.2	2.5	3.0	R35	R50
2-0/5-2		23-1/2	61-1/2	18-7/16	19-11/16	2.5	6.4	2.5	3.0	R35	R50
2-0/5-6		23-1/2	65-1/2	18-7/16	21-1/4	2.7	6.9	2.5	3.0	R30	R50
2-4/3-0		27-1/2	35-1/2	22-7/16	9-1/4	1.4	4.1	2.5	3.0	R35	R50
2-4/3-2		27-1/2	37-1/2	22-7/16	10-1/16	1.5	4.4	2.5	3.0	R35	R50
2-4/3-6		27-1/2	41-1/2	22-7/16	11-11/16	1.8	4.9	2.5	3.0	R35	R50
2-4/3-10		27-1/2	45-1/2	22-7/16	13-1/4	2.0	5.5	2.5	3.0	R35	R50
2-4/4-0		27-1/2	47-1/2	22-7/16	14-1/16	2.1	5.8	2.5	3.0	R35	R50
2-4/4-4		27-1/2	51-1/2	22-7/16	15-11/16	2.4	6.4	2.5	3.0	R35	R50
2-4/4-6		27-1/2	53-1/2	22-7/16	16-7/16	2.5	6.7	2.5	3.0	R35	R50
2-4/5-0		27-1/2	59-1/2	22-7/16	18-7/8	2.9	7.6	2.5	3.0	R35	R50
2-4/5-2		27-1/2	61-1/2	22-7/16	19-11/16	3.0	7.9	2.5	3.0	R35	R50
2-4/5-6		27-1/2	65-1/2	22-7/16	21-1/4	3.3	8.5	2.5	3.0	R30	R50
2-6/3-0		29-1/2	35-1/2	24-7/16	9-1/4	1.5	4.4	2.5	3.0	R35	R50
2-6/3-2		29-1/2	37-1/2	24-7/16	10-1/16	1.7	4.8	2.5	3.0	R35	R50
2-6/3-6		29-1/2	41-1/2	24-7/16	11-11/16	1.9	5.4	2.5	3.0	R35	R50
2-6/3-10		29-1/2	45-1/2	24-7/16	13-1/4	2.2	6.1	2.5	3.0	R35	R50
2-6/4-0		29-1/2	47-1/2	24-7/16	14-1/16	2.3	6.4	2.5	3.0	R35	R50
2-6/4-4		29-1/2	51-1/2	24-7/16	15-11/16	2.6	7.0	2.5	3.0	R35	R50
2-6/4-6		29-1/2	53-1/2	24-7/16	16-7/16	2.7	7.3	2.5	3.0	R35	R50
2-6/5-0		29-1/2	59-1/2	24-7/16	18-7/8	3.2	8.3	2.5	3.0	R35	R50
2-6/5-2		29-1/2	61-1/2	24-7/16	19-11/16	3.3	8.6	2.5	3.0	R35	R50
2-6/5-6		29-1/2	65-1/2	24-7/16	21-1/4	3.6	9.3	2.5	3.0	R30	R50
2-8/3-0		31-1/2	35-1/2	26-7/16	9-1/4	1.7	4.8	2.5	3.0	R35	R50
2-8/3-2		31-1/2	37-1/2	26-7/16	10-1/16	1.8	5.2	2.5	3.0	R35	R50
2-8/3-6		31-1/2	41-1/2	26-7/16	11-11/16	2.1	5.9	2.5	3.0	R35	R50
2-8/3-10		31-1/2	45-1/2	26-7/16	13-1/4	2.4	6.6	2.5	3.0	R35	R50
2-8/4-0		31-1/2	47-1/2	26-7/16	14-1/16	2.5	6.9	2.5	3.0	R35	R50
2-8/4-4		31-1/2	51-1/2	26-7/16	15-11/16	2.8	7.6	2.5	3.0	R35	R50
2-8/4-6		31-1/2	53-1/2	26-7/16	16-7/16	3.0	8.0	2.5	3.0	R35	R50
2-8/5-0		31-1/2	59-1/2	26-7/16	18-7/8	3.4	9.0	2.5	3.0	R35	R50
2-8/5-2		31-1/2	61-1/2	26-7/16	19-11/16	3.6	9.4	2.5	3.0	R35	R50
2-8/5-6		31-1/2	65-1/2	26-7/16	21-1/4	3.9	10.1	2.5	3.0	R30	R50
3-0/3-0		35-1/2	35-1/2	30-7/16	9-1/4	1.9	5.6	2.5	3.0	R35	R50
3-0/3-2		35-1/2	37-1/2	30-7/16	10-1/16	2.1	6.0	2.5	3.0	R35	R50
3-0/3-6		35-1/2	41-1/2	30-7/16	11-11/16	2.4	6.8	2.5	3.0	R35	R50
3-0/3-10		35-1/2	45-1/2	30-7/16	13-1/4	2.8	7.6	2.5	3.0	R35	R50
3-0/4-0		35-1/2	47-1/2	30-7/16	14-1/16	2.9	8.0	2.5	3.0	R35	R50
3-0/4-4		35-1/2	51-1/2	30-7/16	15-11/16	3.3	8.8	2.5	3.0	R35	R50
3-0/4-6		35-1/2	53-1/2	30-7/16	16-7/16	3.4	9.2	2.5	3.0	R35	R50
3-0/5-0		35-1/2	59-1/2	30-7/16	18-7/8	3.9	10.5	2.5	3.0	R35	R50
3-0/5-2		35-1/2	61-1/2	30-7/16	19-11/16	4.1	10.9	2.5	3.0	R35	R50
3-0/5-6		35-1/2	65-1/2	30-7/16	21-1/4	4.5	11.7	2.5	3.0	R30	R50
3-2/3-0		37-1/2	35-1/2	32-7/16	9-1/4	2.0	6.0	2.5	3.0	R30	R50

(1) Maximum performance when glazed with the appropriate glass thickness.





# 250 Series Double-Hung

## Design Data

1-Wide Vent Units – Contemporary Sash											
Unit	Egress	Frame (Inches)		Clear Opening (Vent Units Only) (Inches)			Visible Glass Ft <sup>2</sup>	Glass Thickness (mm)		Performance Class & Grade <sup>(1)</sup>	
		Width	Height	Width	Height	Ft <sup>2</sup>		Annealed	Tempered	Standard	Upgrade
3-2/3-2		37-1/2	37-1/2	32-7/16	10-1/16	2.2	6.4	2.5	3.0	R30	R50
3-2/3-6		37-1/2	41-1/2	32-7/16	11-11/16	2.6	7.3	2.5	3.0	R30	R50
3-2/3-10		37-1/2	45-1/2	32-7/16	13-1/4	2.9	8.1	2.5	3.0	R30	R50
3-2/4-0		37-1/2	47-1/2	32-7/16	14-1/16	3.1	8.6	2.5	3.0	R30	R50
3-2/4-4		37-1/2	51-1/2	32-7/16	15-11/16	3.5	9.4	2.5	3.0	R30	R50
3-2/4-6		37-1/2	53-1/2	32-7/16	16-7/16	3.7	9.9	2.5	3.0	R30	R50
3-2/5-0		37-1/2	59-1/2	32-7/16	18-7/8	4.2	11.2	2.5	3.0	R30	R50
3-2/5-2		37-1/2	61-1/2	32-7/16	19-11/16	4.4	11.6	2.5	3.0	R30	R50
3-2/5-6		37-1/2	65-1/2	32-7/16	21-1/4	4.7	12.5	2.5	3.0	R30	R50
3-6/3-0		41-1/2	35-1/2	36-7/16	9-1/4	2.3	6.7	2.5	3.0	R30	R50
3-6/3-2		41-1/2	37-1/2	36-7/16	10-1/16	2.5	7.2	2.5	3.0	R30	R50
3-6/3-6		41-1/2	41-1/2	36-7/16	11-11/16	2.9	8.2	2.5	3.0	R30	R50
3-6/3-10		41-1/2	45-1/2	36-7/16	13-1/4	3.3	9.2	2.5	3.0	R30	R50
3-6/4-0		41-1/2	47-1/2	36-7/16	14-1/16	3.5	9.7	2.5	3.0	R30	R50
3-6/4-4		41-1/2	51-1/2	36-7/16	15-11/16	3.9	10.6	2.5	3.0	R30	R50
3-6/4-6		41-1/2	53-1/2	36-7/16	16-7/16	4.1	11.1	2.5	3.0	R30	R50
3-6/5-0		41-1/2	59-1/2	36-7/16	18-7/8	4.7	12.6	2.5	3.0	R30	R50
3-6/5-2		41-1/2	61-1/2	36-7/16	19-11/16	4.9	13.1	2.5	3.0	R30	R50
3-6/5-6		41-1/2	65-1/2	36-7/16	21-1/4	5.3	14.1	2.5	3.0	R20	R50
4-0/3-0		47-1/2	35-1/2	42-7/16	9-1/4	2.7	7.9	2.5	3.0	R30	R50
4-0/3-2		47-1/2	37-1/2	42-7/16	10-1/16	2.9	8.5	2.5	3.0	R30	R50
4-0/3-6		47-1/2	41-1/2	42-7/16	11-11/16	3.4	9.6	2.5	3.0	R30	R50
4-0/3-10		47-1/2	45-1/2	42-7/16	13-1/4	3.9	10.7	2.5	3.0	R30	R50
4-0/4-0		47-1/2	47-1/2	42-7/16	14-1/16	4.1	11.3	2.5	3.0	R30	R50
4-0/4-4		47-1/2	51-1/2	42-7/16	15-11/16	4.6	12.5	2.5	3.0	R30	R50
4-0/4-6		47-1/2	53-1/2	42-7/16	16-7/16	4.8	13.0	2.5	3.0	R30	R50
4-0/5-0		47-1/2	59-1/2	42-7/16	18-7/8	5.5	14.8	2.5	3.0	R30	R50
4-0/5-2		47-1/2	61-1/2	42-7/16	19-11/16	5.8	15.3	2.5	3.0	R30	R50
4-0/5-6		47-1/2	65-1/2	42-7/16	21-1/4	6.2	16.5	2.5	3.0	R20	R50
4-6/3-0		53-1/2	35-1/2	48-7/16	9-1/4	3.1	9.0	2.5	3.0	R20	—
4-6/3-2		53-1/2	37-1/2	48-7/16	10-1/16	3.3	9.7	2.5	3.0	R20	—
4-6/3-6		53-1/2	41-1/2	48-7/16	11-11/16	3.9	11.0	2.5	3.0	R20	—
4-6/3-10		53-1/2	45-1/2	48-7/16	13-1/4	4.4	12.3	2.5	3.0	R20	—
4-6/4-0		53-1/2	47-1/2	48-7/16	14-1/16	4.7	13.0	2.5	3.0	R20	—
4-6/4-4		53-1/2	51-1/2	48-7/16	15-11/16	5.2	14.3	2.5	3.0	R20	—
4-6/4-6		53-1/2	53-1/2	48-7/16	16-7/16	5.5	14.9	2.5	3.0	R20	—
4-6/5-0		53-1/2	59-1/2	48-7/16	18-7/8	6.3	16.9	2.5	3.0	R20	—
4-6/5-2		53-1/2	61-1/2	48-7/16	19-11/16	6.6	17.6	2.5	3.0	R20	—
4-6/5-6		53-1/2	65-1/2	48-7/16	21-1/4	7.1	18.9	2.5	3.0	R20	—

(-) = Not Available

(1) Maximum performance when glazed with the appropriate glass thickness.



# 250 Series Double-Hung

## Design Data

2-Wide Vent Unit Composites with Integral Mullion – Contemporary Sash											
Unit	Egress	Frame (Inches)		Clear Opening (Vent Units Only) (Inches)			Visible Glass Ft <sup>2</sup>	Glass Thickness (mm)		Performance Class & Grade <sup>(1)</sup>	
		Width	Height	Width	Height	Ft <sup>2</sup>		Annealed	Tempered	Standard	Upgrade
4-0/3-0		47-1/2	35-1/2	18-7/16	9-1/4	1.1	6.6	2.5	3.0	R35	R50
4-0/3-2		47-1/2	37-1/2	18-7/16	10-1/16	1.2	16.9	2.5	3.0	R35	R50
4-0/3-6		47-1/2	41-1/2	18-7/16	11-11/16	1.4	19.2	2.5	3.0	R35	R50
4-0/3-10		47-1/2	45-1/2	18-7/16	13-1/4	1.7	21.5	2.5	3.0	R35	R50
4-0/4-0		47-1/2	47-1/2	18-7/16	14-1/16	1.8	22.6	2.5	3.0	R35	R50
4-0/4-4		47-1/2	51-1/2	18-7/16	15-11/16	2.0	24.9	2.5	3.0	R35	R50
4-0/4-6		47-1/2	53-1/2	18-7/16	16-7/16	2.1	26.1	2.5	3.0	R35	R50
4-0/5-0		47-1/2	59-1/2	18-7/16	18-7/8	2.4	29.5	2.5	3.0	R35	R50
4-0/5-2		47-1/2	61-1/2	18-7/16	19-11/16	2.5	30.7	2.5	3.0	R35	R50
4-0/5-6		47-1/2	65-1/2	18-7/16	21-1/4	2.7	32.9	2.5	3.0	R30	R50
4-8/3-0		55-1/2	35-1/2	22-7/16	9-1/4	1.4	18.8	2.5	3.0	R35	R50
4-8/3-2		55-1/2	37-1/2	22-7/16	10-1/16	1.5	20.2	2.5	3.0	R35	R50
4-8/3-6		55-1/2	41-1/2	22-7/16	11-11/16	1.8	22.9	2.5	3.0	R35	R50
4-8/3-10		55-1/2	45-1/2	22-7/16	13-1/4	2.0	25.7	2.5	3.0	R35	R50
4-8/4-0		55-1/2	47-1/2	22-7/16	14-1/16	2.1	27.0	2.5	3.0	R35	R50
4-8/4-4		55-1/2	51-1/2	22-7/16	15-11/16	2.4	29.8	2.5	3.0	R35	R50
4-8/4-6		55-1/2	53-1/2	22-7/16	16-7/16	2.5	31.1	2.5	3.0	R35	R50
4-8/5-0		55-1/2	59-1/2	22-7/16	18-7/8	2.9	35.2	2.5	3.0	R35	R50
4-8/5-2		55-1/2	61-1/2	22-7/16	19-11/16	3.0	36.6	2.5	3.0	R35	R50
4-8/5-6		55-1/2	65-1/2	22-7/16	21-1/4	3.3	39.3	2.5	3.0	R30	R50
5-0/3-0		59-1/2	35-1/2	24-7/16	9-1/4	1.5	20.3	2.5	3.0	R35	R50
5-0/3-2		59-1/2	37-1/2	24-7/16	10-1/16	1.7	21.8	2.5	3.0	R35	R50
5-0/3-6		59-1/2	41-1/2	24-7/16	11-11/16	1.9	24.8	2.5	3.0	R35	R50
5-0/3-10		59-1/2	45-1/2	24-7/16	13-1/4	2.2	27.7	2.5	3.0	R35	R50
5-0/4-0		59-1/2	47-1/2	24-7/16	14-1/16	2.3	29.2	2.5	3.0	R35	R50
4-1/4-4		59-1/2	51-1/2	24-7/16	15-11/16	2.6	32.2	2.5	3.0	R35	R50
5-0/4-6		59-1/2	53-1/2	24-7/16	16-7/16	2.7	33.7	2.5	3.0	R35	R50
5-0/5-0		59-1/2	59-1/2	24-7/16	18-7/8	3.2	38.1	2.5	3.0	R35	R50
5-0/5-2		59-1/2	61-1/2	24-7/16	19-11/16	3.3	39.6	2.5	3.0	R35	R50
5-0/5-6		59-1/2	65-1/2	24-7/16	21-1/4	3.6	42.5	2.5	3.0	R30	R50
5-4/3-0		63-1/2	35-1/2	26-7/16	9-1/4	1.7	21.9	2.5	3.0	R35	R50
5-4/3-2		63-1/2	37-1/2	26-7/16	10-1/16	1.8	23.5	2.5	3.0	R35	R50
5-4/3-6		63-1/2	41-1/2	26-7/16	11-11/16	2.1	26.6	2.5	3.0	R35	R50
5-4/3-10		63-1/2	45-1/2	26-7/16	13-1/4	2.4	29.8	2.5	3.0	R35	R50
5-4/4-0		63-1/2	47-1/2	26-7/16	14-1/16	2.5	31.4	2.5	3.0	R35	R50
5-4/4-4		63-1/2	51-1/2	26-7/16	15-11/16	2.8	34.6	2.5	3.0	R35	R50
5-4/4-6		63-1/2	53-1/2	26-7/16	16-7/16	3.0	36.2	2.5	3.0	R35	R50
5-4/5-0		63-1/2	59-1/2	26-7/16	18-7/8	3.4	40.9	2.5	3.0	R35	R50
5-4/5-2		63-1/2	61-1/2	26-7/16	19-11/16	3.6	42.5	2.5	3.0	R35	R50
5-4/5-6		63-1/2	65-1/2	26-7/16	21-1/4	3.9	45.7	2.5	3.0	R30	R50
6-0/3-0		71-1/2	35-1/2	30-7/16	9-1/4	1.9	24.9	2.5	3.0	R35	R50
6-0/3-2		71-1/2	37-1/2	30-7/16	10-1/16	2.1	26.7	2.5	3.0	R35	R50
6-0/3-6		71-1/2	41-1/2	30-7/16	11-11/16	2.4	30.4	2.5	3.0	R35	R50
6-0/3-10		71-1/2	45-1/2	30-7/16	13-1/4	2.8	34.0	2.5	3.0	R35	R50
6-0/4-0		71-1/2	47-1/2	30-7/16	14-1/16	2.9	35.8	2.5	3.0	R35	R50
6-0/4-4		71-1/2	51-1/2	30-7/16	15-11/16	3.3	39.4	2.5	3.0	R35	R50
6-0/4-6		71-1/2	53-1/2	30-7/16	16-7/16	3.4	41.2	2.5	3.0	R35	R50
6-0/5-0		71-1/2	59-1/2	30-7/16	18-7/8	3.9	46.7	2.5	3.0	R35	R50
6-0/5-2		71-1/2	61-1/2	30-7/16	19-11/16	4.1	48.5	2.5	3.0	R35	R50
6-0/5-6		71-1/2	65-1/2	30-7/16	21-1/4	4.5	52.1	2.5	3.0	R30	R50

(-) = Not Available

(1) Maximum performance when glazed with the appropriate glass thickness.



# 250 Series Double-Hung

## Design Data

2-Wide Vent Unit Composites with Integral Mullion – Contemporary Sash											
Unit	Egress	Frame (Inches)		Clear Opening (Vent Units Only) (Inches)			Visible Glass Ft <sup>2</sup>	Glass Thickness (mm)		Performance Class & Grade <sup>(1)</sup>	
		Width	Height	Width	Height	Ft <sup>2</sup>		Annealed	Tempered	Standard	Upgrade
6-4/3-0		75-1/2	35-1/2	32-7/16	9-1/4	2.0	26.4	2.5	3.0	R30	—
6-4/3-2		75-1/2	37-1/2	32-7/16	10-1/16	2.2	28.4	2.5	3.0	R30	—
6-4/3-6		75-1/2	41-1/2	32-7/16	11-11/16	2.6	32.2	2.5	3.0	R30	—
6-4/3-10		75-1/2	45-1/2	32-7/16	13-1/4	2.9	36.1	2.5	3.0	R30	—
6-4/4-0		75-1/2	47-1/2	32-7/16	14-1/16	3.1	38.0	2.5	3.0	R30	—
6-4/4-4		75-1/2	51-1/2	32-7/16	15-11/16	3.5	41.8	2.5	3.0	R30	—
6-4/4-6		75-1/2	53-1/2	32-7/16	16-7/16	3.7	43.8	2.5	3.0	R30	—
6-4/5-0		75-1/2	59-1/2	32-7/16	18-7/8	4.2	49.5	2.5	3.0	R30	—
6-4/5-2		75-1/2	61-1/2	32-7/16	19-11/16	4.4	51.5	2.5	3.0	R30	—
6-4/5-6		75-1/2	65-1/2	32-7/16	21-1/4	4.7	55.3	2.5	3.0	R20	—
7-0/3-0		83-1/2	35-1/2	42-7/16	9-1/4	2.3	29.5	2.5	3.0	R30	—
7-0/3-2		83-1/2	37-1/2	42-7/16	10-1/16	2.5	31.7	2.5	3.0	R30	—
7-0/3-6		83-1/2	41-1/2	42-7/16	11-11/16	2.9	35.9	2.5	3.0	R30	—
7-0/3-10		83-1/2	45-1/2	42-7/16	13-1/4	3.3	40.2	2.5	3.0	R30	—
7-0/4-0		83-1/2	47-1/2	42-7/16	14-1/16	3.5	42.4	2.5	3.0	R30	—
7-0/4-4		83-1/2	51-1/2	42-7/16	15-11/16	3.9	46.7	2.5	3.0	R30	—
7-0/4-6		83-1/2	53-1/2	42-7/16	16-7/16	4.1	48.8	2.5	3.0	R30	—
7-0/5-0		83-1/2	59-1/2	42-7/16	18-7/8	4.7	55.3	2.5	3.0	R30	—
7-0/5-2		83-1/2	61-1/2	42-7/16	19-11/16	4.9	57.4	2.5	3.0	R30	—
7-0/5-6		83-1/2	65-1/2	42-7/16	21-1/4	5.3	61.7	2.5	3.0	R20	—
8-0/3-0		95-1/2	35-1/2	48-7/16	9-1/4	2.7	34.1	2.5	3.0	R30	—
8-0/3-2		95-1/2	37-1/2	48-7/16	10-1/16	2.9	36.6	2.5	3.0	R30	—
8-0/3-6		95-1/2	41-1/2	48-7/16	11-11/16	3.4	41.5	2.5	3.0	R30	—
8-0/3-10		95-1/2	45-1/2	48-7/16	13-1/4	3.9	46.5	2.5	3.0	R30	—
8-0/4-0		95-1/2	47-1/2	48-7/16	14-1/16	4.1	49.0	2.5	3.0	R30	—
8-0/4-4		95-1/2	51-1/2	48-7/16	15-11/16	4.6	53.9	2.5	3.0	R30	—
8-0/4-6		95-1/2	53-1/2	48-7/16	16-7/16	4.8	56.4	2.5	3.0	R30	—
8-0/5-0		95-1/2	59-1/2	48-7/16	18-7/8	5.5	63.8	2.5	3.0	R30	—
8-0/5-2		95-1/2	61-1/2	48-7/16	19-11/16	5.8	66.3	2.5	3.0	R30	—
8-0/5-6		95-1/2	65-1/2	48-7/16	21-1/4	6.2	71.3	2.5	3.0	R20	—
4-0/3-0		95-1/2	35-1/2	48-7/16	9-1/4	2.7	34.1	2.5	3.0	R30	—
4-0/3-2		95-1/2	37-1/2	48-7/16	10-1/16	2.9	36.6	2.5	3.0	R30	—
4-0/3-6		95-1/2	41-1/2	48-7/16	11-11/16	3.4	41.5	2.5	3.0	R30	—
4-0/3-10		95-1/2	45-1/2	48-7/16	13-1/4	3.9	46.5	2.5	3.0	R30	—
4-0/4-0		95-1/2	47-1/2	48-7/16	14-1/16	4.1	49.0	2.5	3.0	R30	—
4-0/4-4		95-1/2	51-1/2	48-7/16	15-11/16	4.6	53.9	2.5	3.0	R30	—
4-0/4-6		95-1/2	53-1/2	48-7/16	16-7/16	4.8	56.4	2.5	3.0	R30	—
4-0/5-0		95-1/2	59-1/2	48-7/16	18-7/8	5.5	63.8	2.5	3.0	R30	—
4-0/5-2		95-1/2	61-1/2	48-7/16	19-11/16	5.8	66.3	2.5	3.0	R30	—
4-0/5-6		95-1/2	65-1/2	48-7/16	21-1/4	6.2	71.3	2.5	3.0	R20	—

(—) = Not Available

(1) Maximum performance when glazed with the appropriate glass thickness.



# 250 Series Double-Hung

## Design Data

3-Wide Vent Unit Composites with Integral Mullion — Contemporary Sash											
Unit	Egress	Frame (Inches)		Clear Opening (Vent Units Only) (Inches)			Visible Glass Ft <sup>2</sup>	Glass Thickness (mm)		Performance Class & Grade <sup>(1)</sup>	
		Width	Height	Width	Height	Ft <sup>2</sup>		Annealed	Tempered	Standard	Upgrade
6-0/3-0		71-1/2	35-1/2	18-7/16	9-1/4	1.1	9.9	2.5	3.0	R35	—
6-0/3-2		71-1/2	37-1/2	18-7/16	10-1/16	1.2	10.6	2.5	3.0	R35	—
6-0/3-6		71-1/2	41-1/2	18-7/16	11-11/16	1.4	12.0	2.5	3.0	R35	—
6-0/3-10		71-1/2	45-1/2	18-7/16	13-1/4	1.7	13.5	2.5	3.0	R35	—
6-0/4-0		71-1/2	47-1/2	18-7/16	14-1/16	1.8	14.2	2.5	3.0	R35	—
6-0/4-3		71-1/2	51-1/2	18-7/16	15-11/16	2.0	15.6	2.5	3.0	R35	—
6-0/4-6		71-1/2	53-1/2	18-7/16	16-7/16	2.1	16.4	2.5	3.0	R35	—
6-0/5-0		71-1/2	59-1/2	18-7/16	18-7/8	2.4	18.5	2.5	3.0	R35	—
6-0/5-2		71-1/2	61-1/2	18-7/16	19-11/16	2.5	19.2	2.5	3.0	R35	—
6-0/5-6		71-1/2	65-1/2	18-7/16	21-1/4	2.7	20.7	2.5	3.0	R30	—
7-0/3-0		83-1/2	35-1/2	22-7/16	9-1/4	1.4	12.2	2.5	3.0	R35	—
7-0/3-2		83-1/2	37-1/2	22-7/16	10-1/16	1.5	13.1	2.5	3.0	R35	—
7-0/3-6		83-1/2	41-1/2	22-7/16	11-11/16	1.8	14.8	2.5	3.0	R35	—
7-0/3-10		83-1/2	45-1/2	22-7/16	13-1/4	2.0	16.6	2.5	3.0	R35	—
7-0/4-0		83-1/2	47-1/2	22-7/16	14-1/16	2.1	17.5	2.5	3.0	R35	—
7-0/4-3		83-1/2	51-1/2	22-7/16	15-11/16	2.4	19.3	2.5	3.0	R35	—
7-0/4-6		83-1/2	53-1/2	22-7/16	16-7/16	2.5	20.1	2.5	3.0	R35	—
7-0/5-0		83-1/2	59-1/2	22-7/16	18-7/8	2.9	22.8	2.5	3.0	R35	—
7-0/5-2		83-1/2	61-1/2	22-7/16	19-11/16	3.0	23.7	2.5	3.0	R35	—
7-0/5-6		83-1/2	65-1/2	22-7/16	21-1/4	3.3	25.5	2.5	3.0	R30	—
7-6/3-0		89-1/2	35-1/2	24-7/16	9-1/4	1.5	13.3	2.5	3.0	R35	—
7-6/3-2		89-1/2	37-1/2	24-7/16	10-1/16	1.7	14.3	2.5	3.0	R35	—
7-6/3-6		89-1/2	41-1/2	24-7/16	11-11/16	1.9	16.2	2.5	3.0	R35	—
7-6/3-10		89-1/2	45-1/2	24-7/16	13-1/4	2.2	18.2	2.5	3.0	R35	—
7-6/4-0		89-1/2	47-1/2	24-7/16	14-1/16	2.3	19.1	2.5	3.0	R35	—
7-6/4-3		89-1/2	51-1/2	24-7/16	15-11/16	2.6	21.1	2.5	3.0	R35	—
7-6/4-6		89-1/2	53-1/2	24-7/16	16-7/16	2.7	22.0	2.5	3.0	R35	—
7-6/5-0		89-1/2	59-1/2	24-7/16	18-7/8	3.2	24.9	2.5	3.0	R35	—
7-6/5-2		89-1/2	61-1/2	24-7/16	19-11/16	3.3	25.9	2.5	3.0	R35	—
7-6/5-6		89-1/2	65-1/2	24-7/16	21-1/4	3.6	27.9	2.5	3.0	R30	—
8-0/3-0		95-1/2	35-1/2	26-7/16	9-1/4	1.7	14.5	2.5	3.0	R35	—
8-0/3-2		95-1/2	37-1/2	26-7/16	10-1/16	1.8	15.5	2.5	3.0	R35	—
8-0/3-6		95-1/2	41-1/2	26-7/16	11-11/16	2.1	17.6	2.5	3.0	R35	—
8-0/3-10		95-1/2	45-1/2	26-7/16	13-1/4	2.4	19.7	2.5	3.0	R35	—
8-0/4-0		95-1/2	47-1/2	26-7/16	14-1/16	2.5	20.8	2.5	3.0	R35	—
8-0/4-3		95-1/2	51-1/2	26-7/16	15-11/16	2.8	22.9	2.5	3.0	R35	—
8-0/4-6		95-1/2	53-1/2	26-7/16	16-7/16	3.0	23.9	2.5	3.0	R35	—
8-0/5-0		95-1/2	59-1/2	26-7/16	18-7/8	3.4	27.1	2.5	3.0	R35	—
8-0/5-2		95-1/2	61-1/2	26-7/16	19-11/16	3.6	28.1	2.5	3.0	R35	—
8-0/5-6		95-1/2	65-1/2	26-7/16	21-1/4	3.9	30.2	2.5	3.0	R30	—
9-0/3-0		107-1/2	35-1/2	30-7/16	9-1/4	1.9	16.8	2.5	3.0	R35	—
9-0/3-2		107-1/2	37-1/2	30-7/16	10-1/16	2.1	18.0	2.5	3.0	R35	—
9-0/3-6		107-1/2	41-1/2	30-7/16	11-11/16	2.4	20.4	2.5	3.0	R35	—
9-0/3-10		107-1/2	45-1/2	30-7/16	13-1/4	2.8	22.9	2.5	3.0	R35	—
9-0/4-0		107-1/2	47-1/2	30-7/16	14-1/16	2.9	24.1	2.5	3.0	R35	—
9-0/4-3		107-1/2	51-1/2	30-7/16	15-11/16	3.3	26.5	2.5	3.0	R35	—
9-0/4-6		107-1/2	53-1/2	30-7/16	16-7/16	3.4	27.7	2.5	3.0	R35	—
9-0/5-0		107-1/2	59-1/2	30-7/16	18-7/8	3.9	31.4	2.5	3.0	R35	—
9-0/5-2		107-1/2	61-1/2	30-7/16	19-11/16	4.1	32.6	2.5	3.0	R35	—

**Egress Notes:**

Check all applicable local codes for emergency egress requirements.

E1 = Window meets minimum clear opening of 24" height, 20" width, and 5.0 ft<sup>2</sup>.

To convert areas to square meters (m<sup>2</sup>), multiply square feet by 0.0929.

(—) = Not Available

(1) Maximum performance when glazed with the appropriate glass thickness.



### Frame

- Overall frame depth: 3-1/4" on all frame types.
- Frame members are mitered and heat fused to provide a fully welded corner assembly. Sill is fitted with weeps.
- Frame: [1-1/8" setback nail fin for 2-1/8" wall depth] [nail fin with flat casing for 2-1/8" wall depth<sup>1</sup>] [Block frame for 3-1/4" wall depth] [Double Wall Flush Flange for 3" wall depth] [Integral 5/8" flange for 3" wall depth].
- Interior and exterior frame surfaces are extruded rigid uPVC.

### Sash

- Sash members are extruded, rigid uPVC [with optional foam insulation].
- Sash members are mitered and heat-fused to provide a fully welded corner assembly.
- Includes an integral extruded sash lift as standard.
- Contains sealed insulating glass.

### Weatherstripping

- Sash is weatherstripped around the sash perimeter with a fin-type, pile weatherstripping and vinyl wrapped foam weatherstrip.

### Glazing System

- Quality float glass complying with ASTM C 1036.
- Exterior face-glazed sealed insulating glass.
- Dual-Pane insulating glass [[annealed] [tempered]] [[Advanced] [NaturalSun] [SunDefense™] Low-E coated [with Argon]] [[NaturalSun+] [SunDefense+] Low-E with argon]] [Bronze, Advanced Low-E coated [with Argon]] [Obscure<sub>3</sub>] [High Altitude<sub>2</sub>].
- 1" Triple-Pane [[annealed] [tempered]] [[Advanced] [NaturalSun] Low-E coated [with Argon]] [Obscure<sub>3</sub>] [High Altitude<sub>2</sub>].

### Interior / Exterior

- Window frame and sash members are [[White] [Almond] [Fossil] with integral color extruded throughout the profiles] [[Brown] [Black] laminate exterior, consisting of a solar reflective coating exceeding AAMA 307 test requirements, with White integral color extruded throughout the profiles on the interior].
- All exposed PVC surfaces are smooth, glossy and uniform in appearance.

### Hardware

- Constant force balances connected to sash with stainless steel spring and concealed within the frame.
- Upper and lower sashes are fully operable for ventilation.
- All fasteners are corrosion-resistant material compatible with PVC.
- Locks are factory-installed, zinc die cast, self-aligning, [cam action locks] [AutoLock] located on the check rail. Two sash locks are installed on units with 29-1/2" or greater frame width.
- Tilt latches are factory installed, [zinc die cast (advanced performance)] [nylon 6 (standard)] and are located on the check rail of the lower sash and the top rail of the upper sash.
- Hardware finish is [White] [Almond] [Fossil].

### Screens

- [Full-size] [Half-screen] Set in aluminum frame and fitted to exterior of window.
- Screen frame finish is baked enamel, color to match exterior
- Screens for windows with frame width >39" or frame height > 53-1/2" have a screen spreader bar.
- InView™ flat screen
  - Black vinyl coated 18/18 mesh fiberglass screen cloth complying with ASTM D 3656 and SMA 1201.
- Hidden screen (Available only to select markets/sales channels, contact your local sales representative for details).

### Optional Products

#### Grilles

- Grilles-Between-the-Glass
  - [Dual-Pane Insulating glass contains [[3/4" [1" contoured] [5/8" flat] aluminum grilles permanently installed between two panes of glass] [Triple-Pane Insulating glass contains 3/4" contoured aluminum grilles permanently installed between three panes of glass].
  - Patterns are [Traditional] [6-Lite Prairie] [9-Lite Prairie] [Top Row].
  - Interior grille color matches interior frame.
  - Exterior grille color [3/4" Grille is [White] [Almond<sub>4</sub>] [Fossil<sub>4</sub>] [Brown] [Black]] [1" Grille is [White] [Almond<sub>4</sub>] [Fossil<sub>4</sub>]] [5/8" Grille is [White] [Almond<sub>4</sub>] [Fossil<sub>4</sub>]].

#### Hardware

- Optional limited opening hardware available for vent units in [White] [Almond] [Fossil] extruded vinyl to match the unit; nominal 3-3/4" opening.
- Optional window opening control device available for factory or field installation. Device allows window to open less than 4" with normal operation, with a release mechanism that allows the sash to open completely. Complies with ASTM F2090-10.

(1) Flat casing availability is limited to Northeast region, not all color options available at launch. Contact your local sales representative for current offering.

(2) Dual-Pane IG High Altitude glazings are available with or without Argon. Triple-Pane IG High Altitude glazings are only available without Argon.

(3) Obscure glass not available with Bronze Advanced, SunDefense+ or NaturalSun+ Low-E IG.

(4) Almond grilles only available on almond units. Almond units with grilles will have an almond grille color, Fossil extruded color units with grilles have a Fossil grille color.



# 250 Series Double-Hung

## Unit sections - Optional Foam Insulation

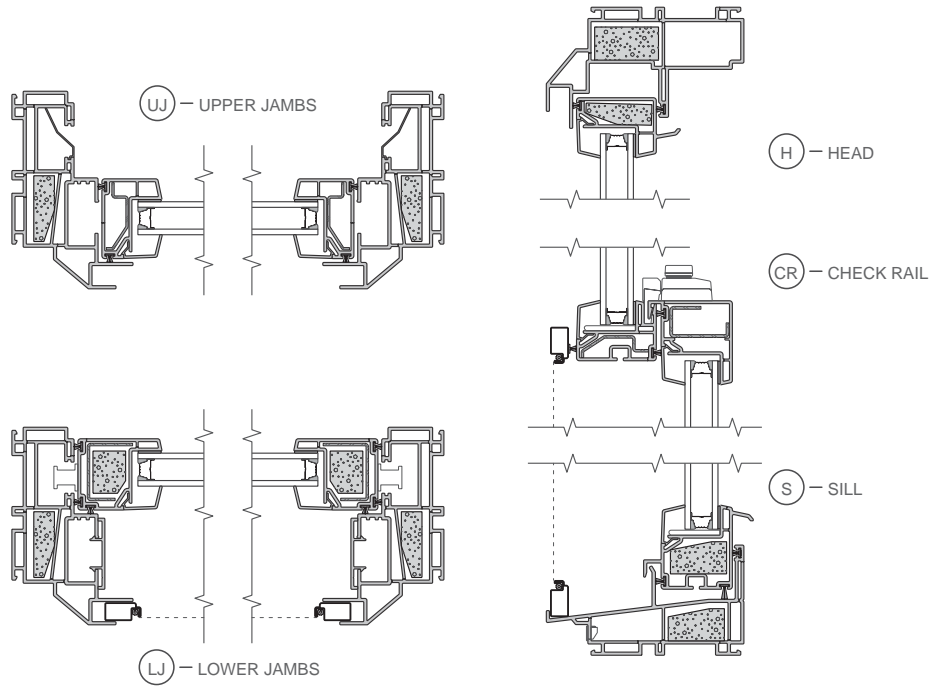

Scale 3" = 1' 0"

All dimensions are approximate.



# 250 Series Double-Hung

## Unit sections - Frame Types

### NEW CONSTRUCTION FRAME

Standard Nailing Fin

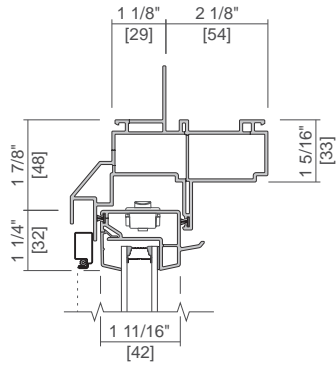

Standard Fin with J-Channel

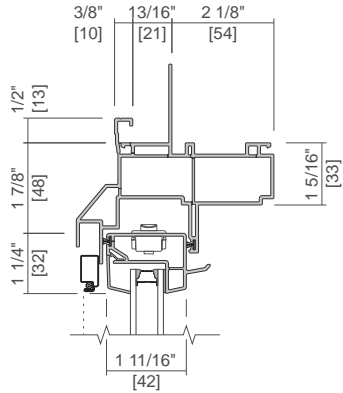

Standard Fin with Flat Casing

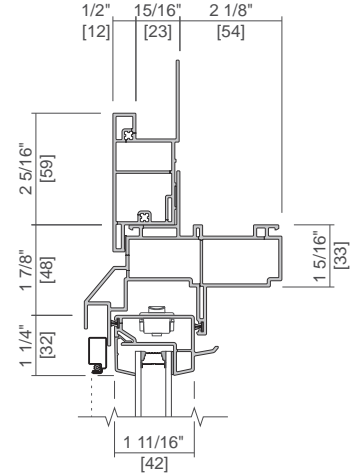

### REPLACEMENT FRAME

Standard Block Frame

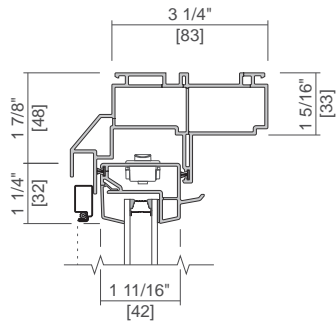

5/8" Flush Flange

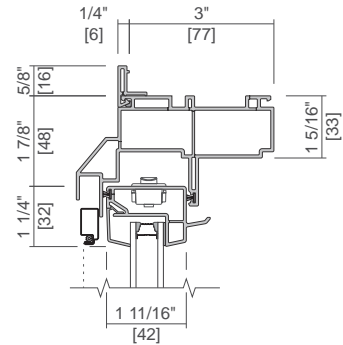

Double Wall Flush Flange

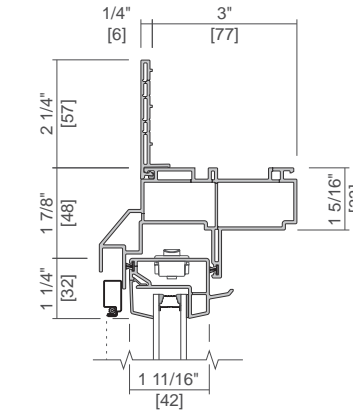

### GLAZING OPTIONS

1 1/16" IG

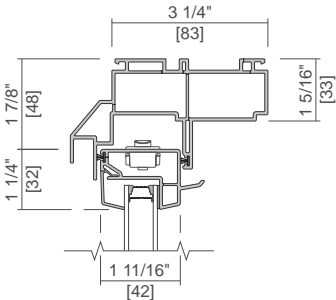

3/4" IG

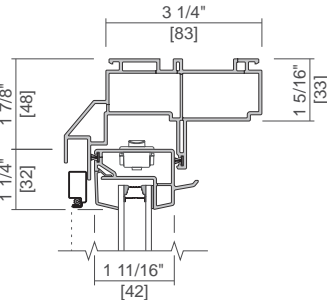

1" Triple IG

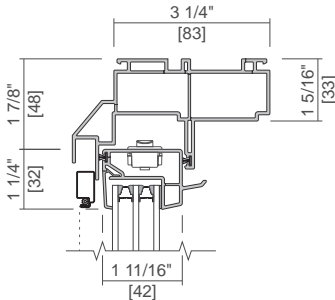

Scale 3" = 1' 0"  
All dimensions are approximate.



# 250 Series Double-Hung

## Unit Sections - Nail Fin

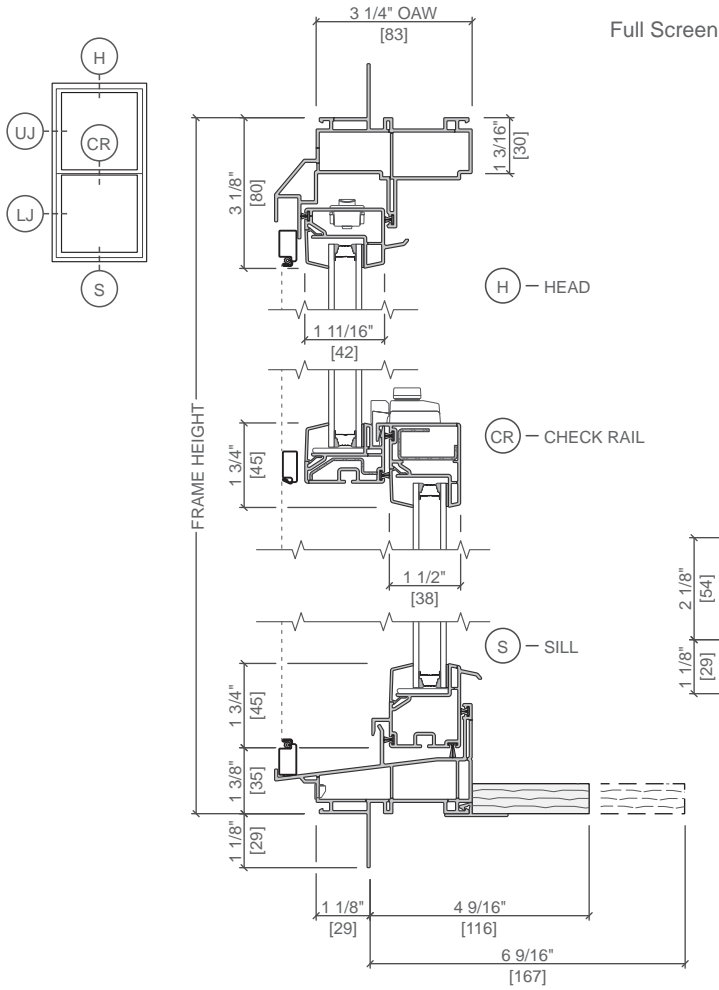

Full Screen

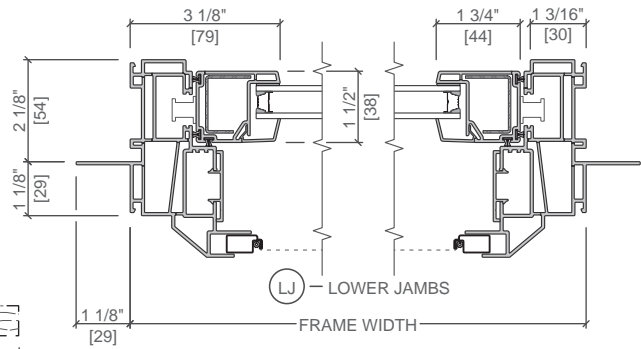
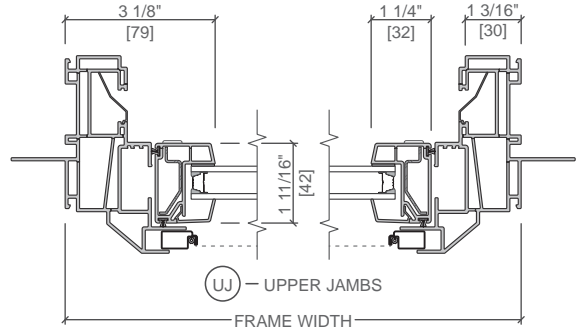

Optional Factory Applied Jamb Extensions

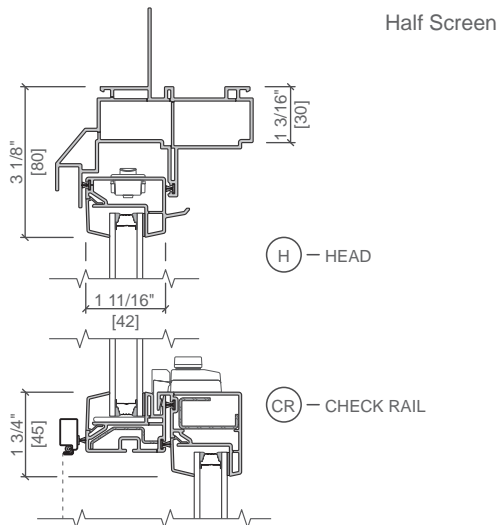
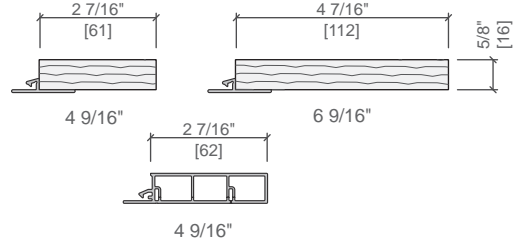

Half Screen

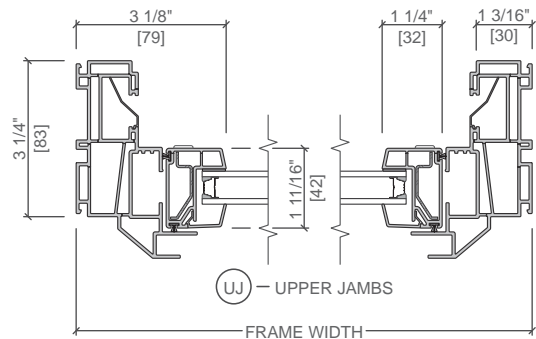

Scale 3" = 1' 0"

All dimensions are approximate.





# 250 Series Double-Hung

## Unit Sections - Nail Fin

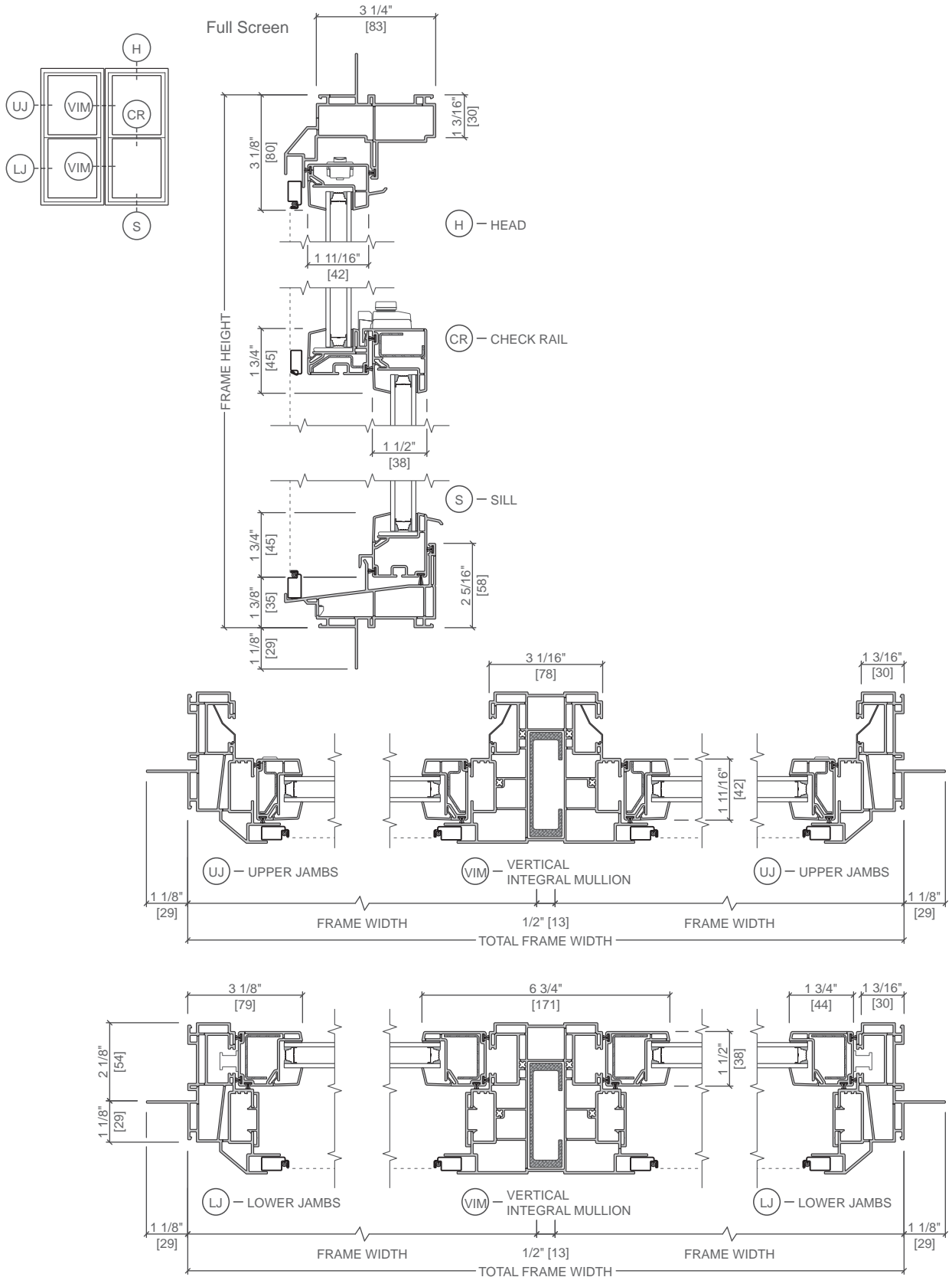

Scale 3" = 1' 0"  
All dimensions are approximate.



# 250 Series Double-Hung

## Unit Sections - Block Frame

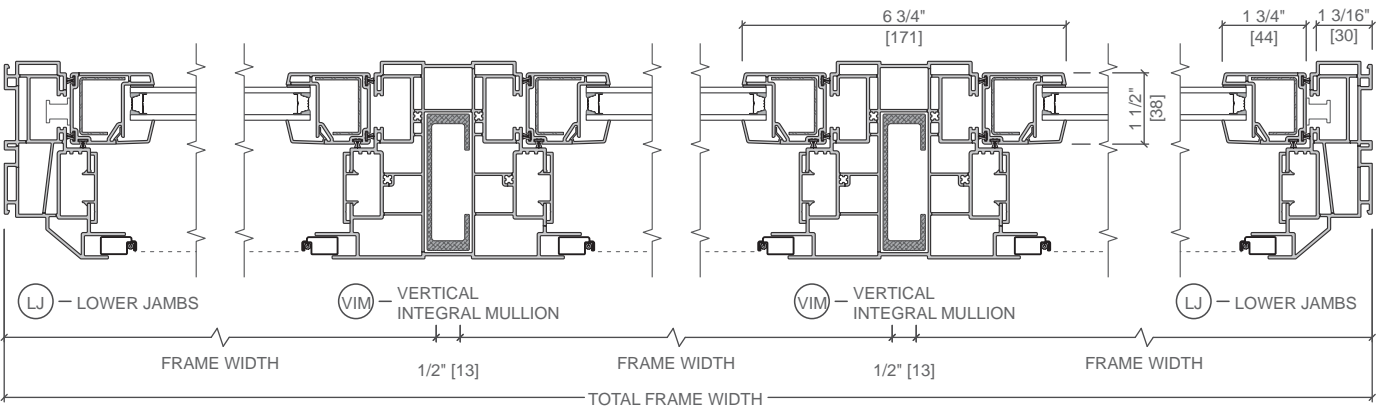
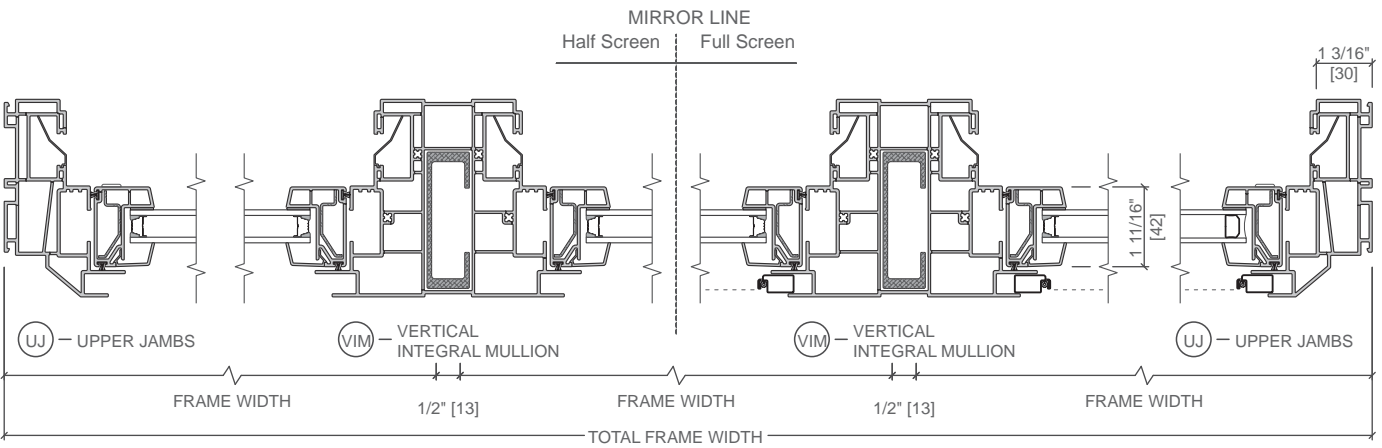
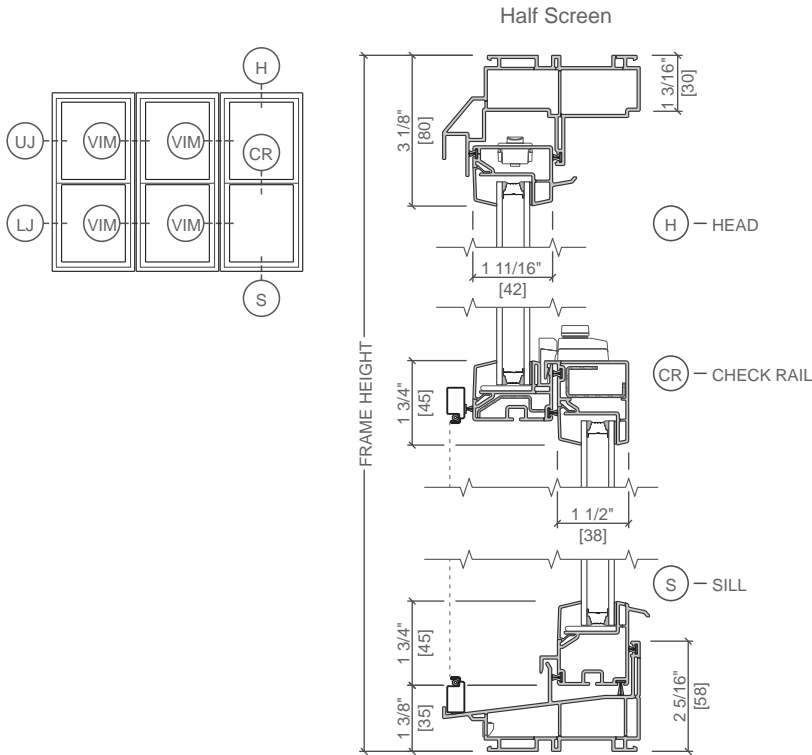

Scale 3" = 1' 0"

All dimensions are approximate.



# 250 Series Double-Hung

## Unit sections - Nail Fin with Flat Casing

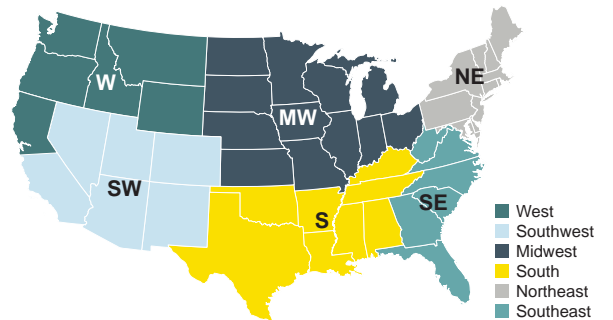
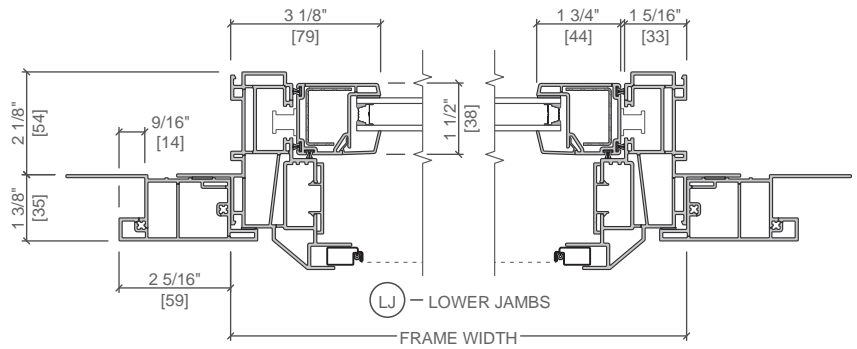
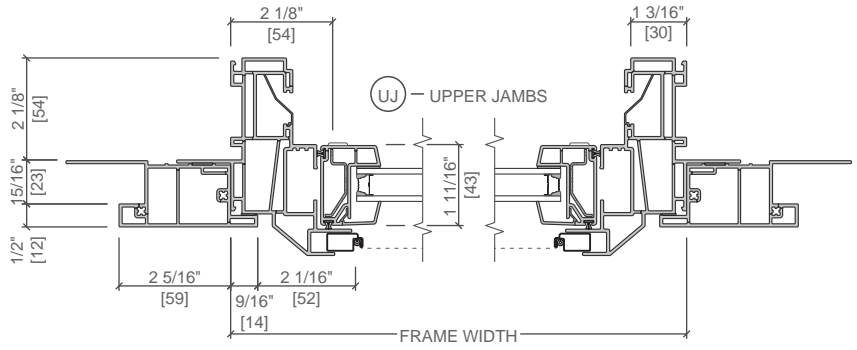
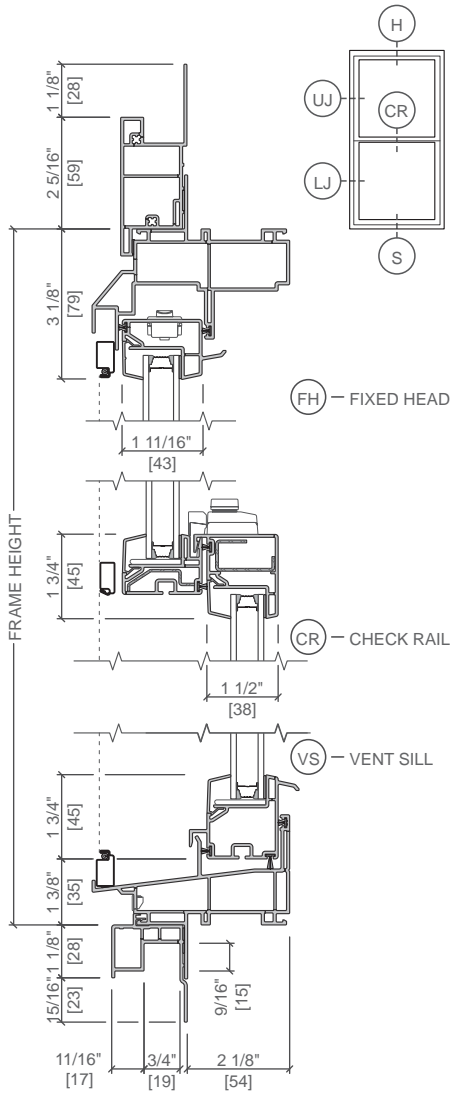

Scale 3" = 1' 0"

All dimensions are approximate.

Flat casing availability is limited to Northeast region. Contact your local sales representative for current offering.