



# Owner's Guide and Installation Manual PELLA® EXPRESS INSTALL® STORM DOORS WITH BLINDS-BETWEEN-THE-GLASS

**NOTE TO THE INSTALLER:** This Owner's Guide and Installation Manual is the property of the homeowner. Please leave it with the homeowner upon completion of the installation.



## Recommended Tools

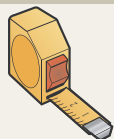

Tape Measure



Power Drill with  
1/8", 3/32", 3/8" drill bits  
(7/8" spade bit included)

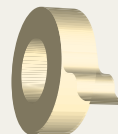

Adhesive Tape

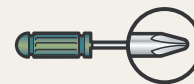

Phillips Screwdriver #2

For safety reasons, the assistance of a second person is recommended when handling the door.

*Read the legend below in order to easily follow along and install your storm door.  
For reference, the storm door assembly is illustrated on page 2.*

## Legend



Follow the steps in order, from 1 to 30.

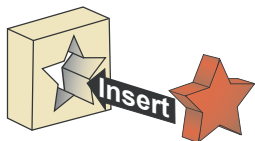

**RED** objects are the action items for that step.



Steps in **BLUE** apply to **LEFT HINGE** configurations **ONLY**.  
(Hinge side will be determined in a later step.)



Steps in **GREEN** apply to **RIGHT HINGE** configurations **ONLY**.  
(Hinge side will be determined in a later step.)

**MUST READ! Instructions in this box style are IMPORTANT!**

To order replacement parts, call  
**1-800-374-4758**

or visit us at

**www.pella.com**

Please have your registration number ready when you contact us either by telephone or on the internet.

**TROUBLESHOOTING GUIDE**  
is located on page 12 of this manual.

Lay door flat. Make sure ALL parts are accounted for before discarding carton.

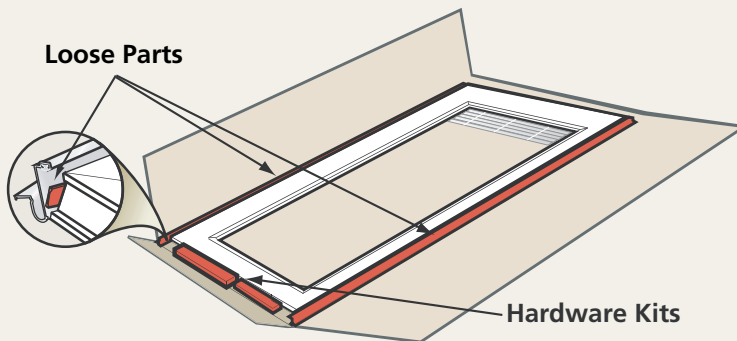

The carton material is recyclable

# Storm Door Components

NOTE: Actual door styles may vary from illustrations, however, the installation steps will be the same.

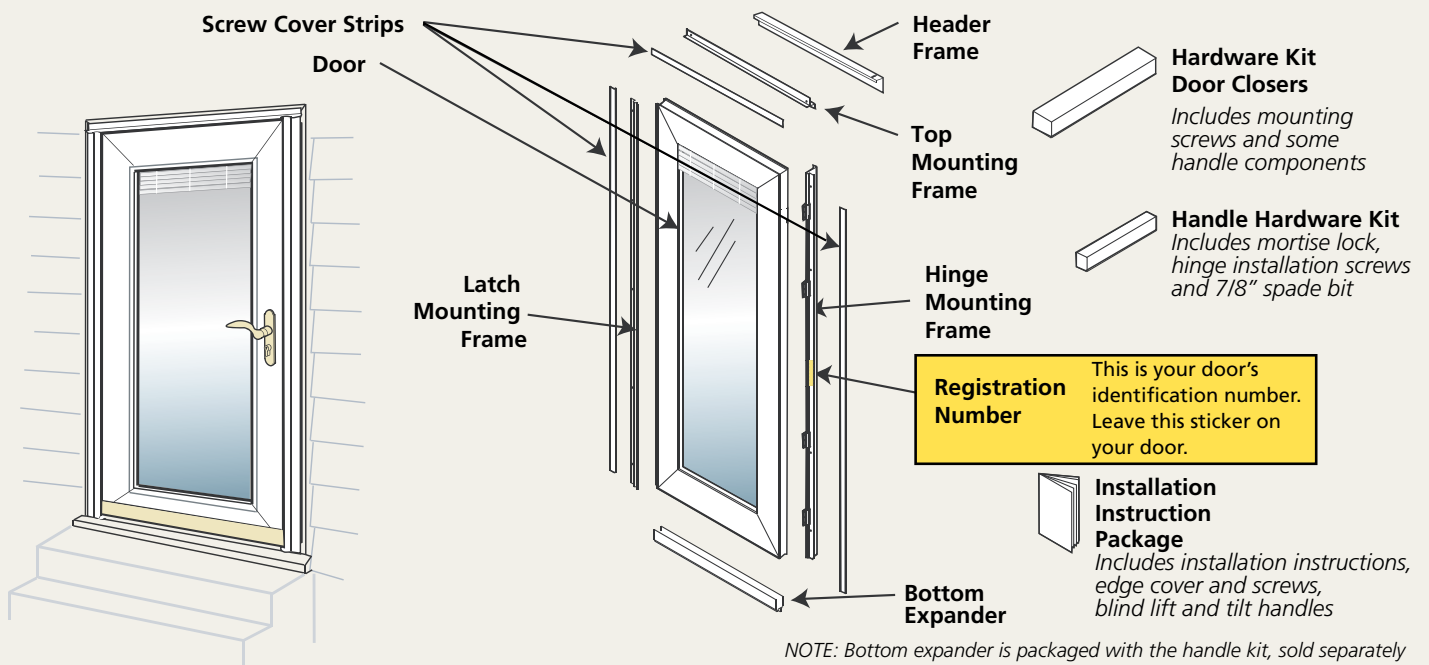

## Before you begin

Make sure brickmold trim is in good condition and securely fastened before beginning installation. It is highly recommended that additional fasteners be used to reinforce brickmold trim.

Follow steps a, b and c to verify your entryway opening requirements.

**a** Locate header frame.

**b** Slide to one side of the entryway.

**c** Measure gap.

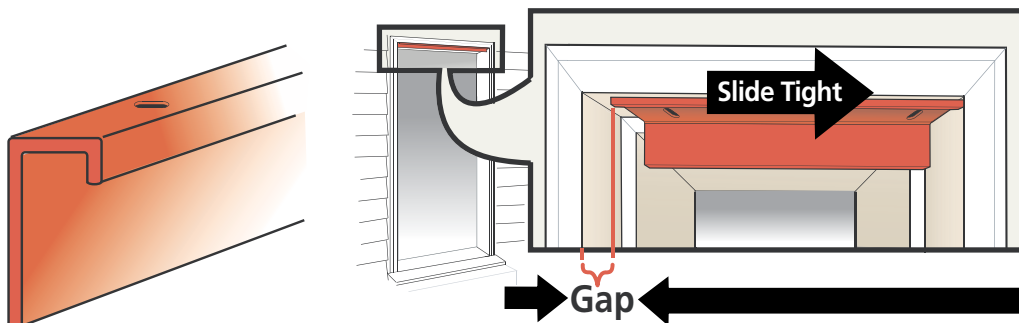

**If this gap is ...**

- LESS than 1/4", Go to **START** on page 3
- 1/4" or GREATER, Go to Step d to shim

**d**

**LEFT HINGE** doors, shim this side

**RIGHT HINGE** doors, shim this side

Shim on YOUR hinge side - see Step 4 on Page 3, to determine your hinge side.

**e**

**Shim**

**Hinge**

Shim may be one long piece or small 8" to 12" sections.  
NOTE: small sections must fully support the hinges on the mounting frame.  
Use an appropriate shim thickness to reduce the gap in step C to 1/4" or less.  
Household shim materials may include paint stir sticks or wooden yardsticks.

**f**

**Shim**

Shim must not extend beyond entryway face

Nail shims in place.  
Note: If you removed an old storm door, you may wish to paint and cover any existing holes before proceeding.  
Go to **START** on page 3.

# START

Your Installation

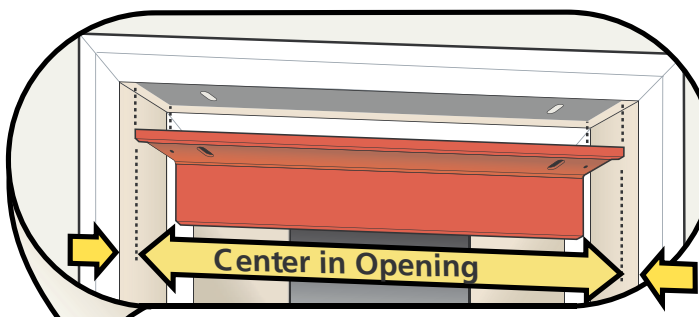

**1** FIRST, center header frame in entryway opening ...

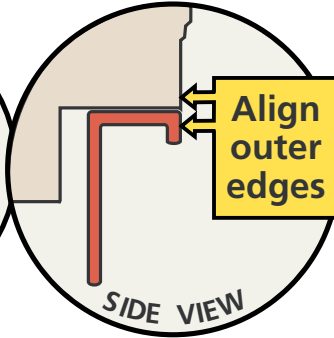

**2** ... THEN, align with face of brickmold.

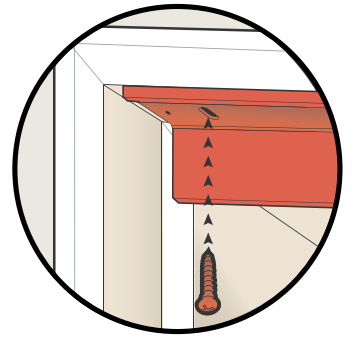

**3** Predrill the two holes. Secure with jamb screws.

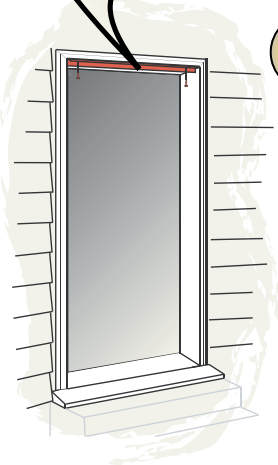

<p>Drill 3/32" Pilot Holes</p>	<p>Qty. 2 "Jamb Screw Bag" unpainted #8 x 3/4" Pan Head</p>
--------------------------------	---

**4** Determine the side you want your door to hinge.

Remove hardware drilling template sticker from **HINGE SIDE** of door only. Position edge cover over mortise hole on hinge side of door. Drill 3/32" pilot holes and secure with screws.

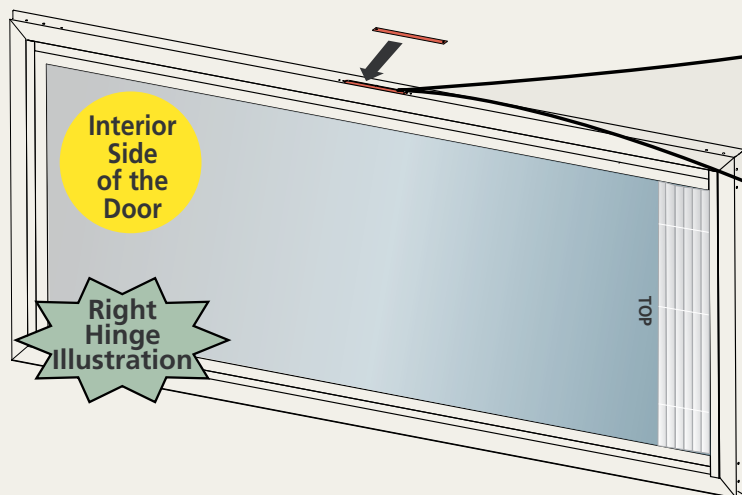

<p>Use a HAND screwdriver</p>	<p>Qty. 2 "Instruction Package" #6 x 1/2" Pan Head</p>
-------------------------------	--

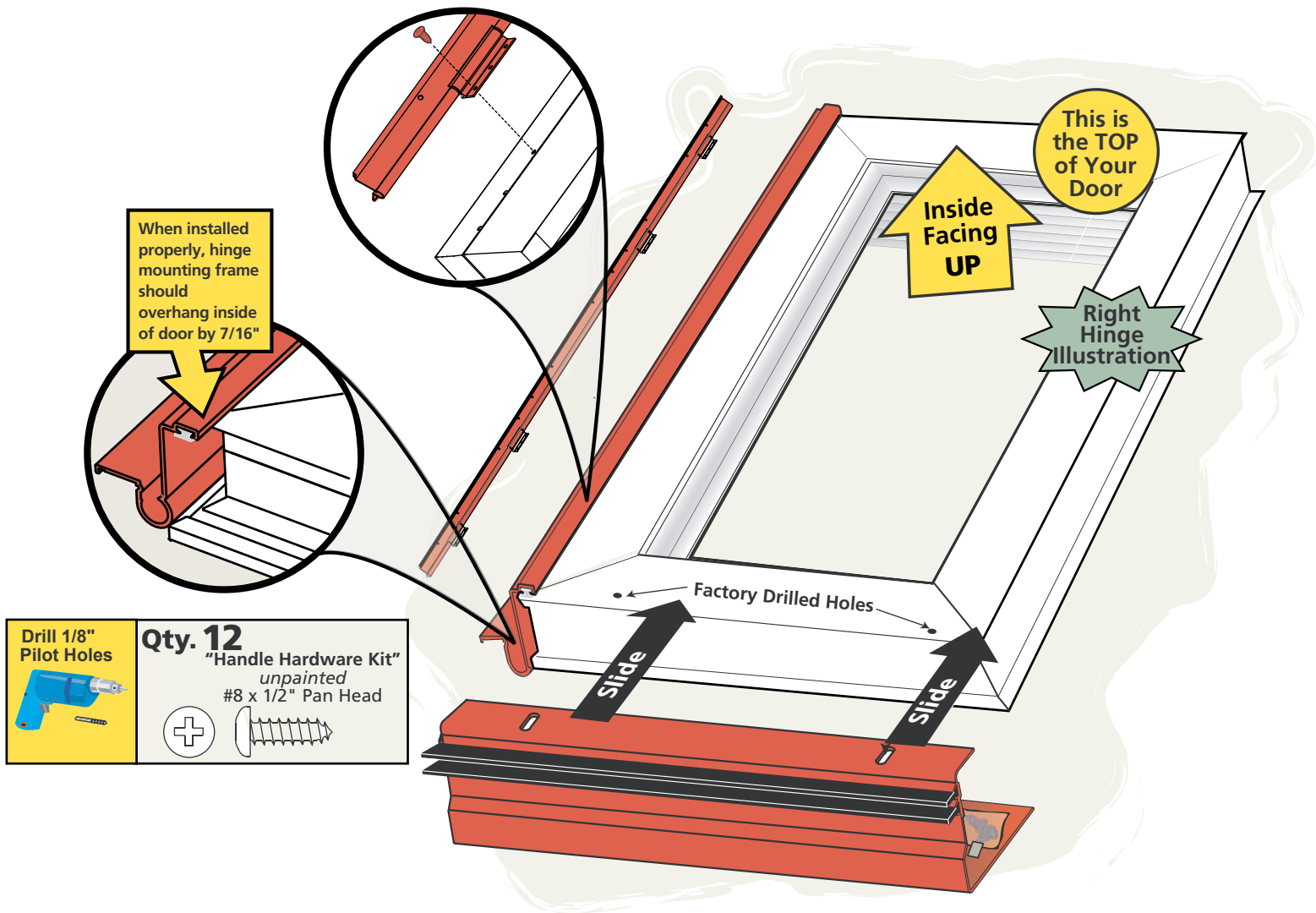

**5** Install hinge mounting frame. Align the outside hole of the hinge with the pilot hole that is pre-drilled on the door. Pilot hole is located toward the bottom of the door on a RH application (as shown here) and toward the top on a LH application. Install screw into hole. Pre-drill remaining hinge holes and install screws.

**6** Locate bottom expander. Remove any protective film and screw packet taped to inside of expander. Save screws for step 29, page 10. Slide bottom expander tight onto bottom of door.

**7** Place installation support block to door's HINGE side. Apply adhesive tape to both sides to secure support block during installation.

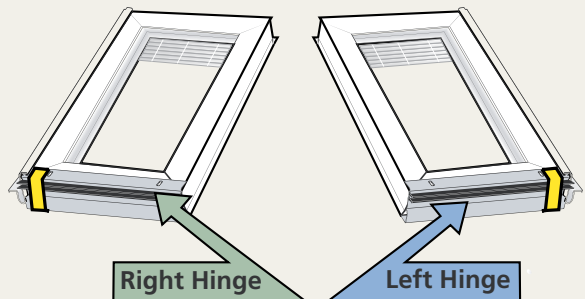
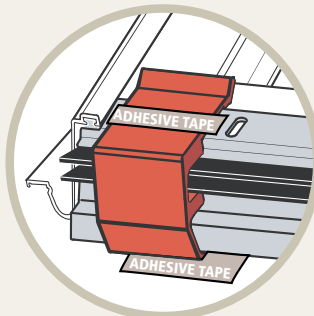



**8**

Set door in opening  
(resting on bottom spacer from step 7).  
Hold tight to hinge side.

**9**

Predrill the five hinge  
side hole locations.  
Secure with screws.

Drill 3/32" Pilot Holes	<b>Qty. 5</b> "Mounting Frame Screw Bag" <i>unpainted</i> #6 x 1" Pan Head
	

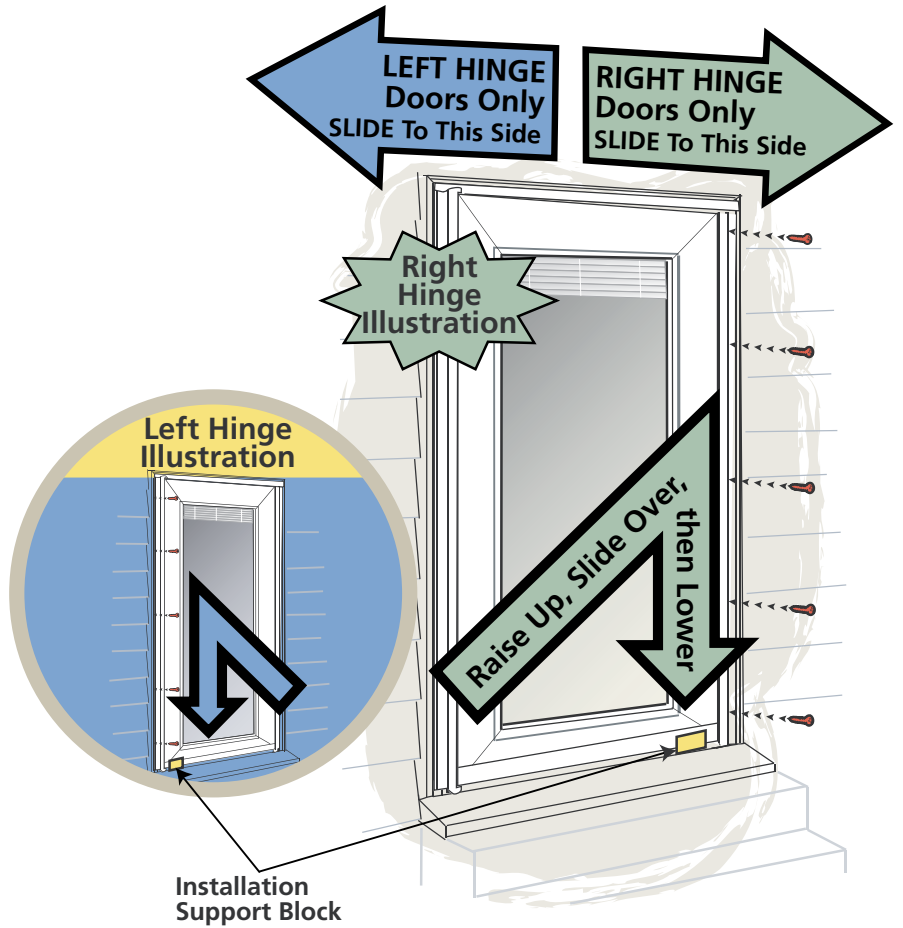

**10**

Open the door.  
Predrill the eight holes.  
Secure with screws.

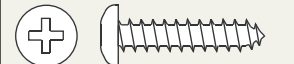
Drill 3/32" Pilot Holes	<b>Qty. 8</b> "Jamb Screw Bag" <i>unpainted</i> #8 x 3/4" Pan Head
	

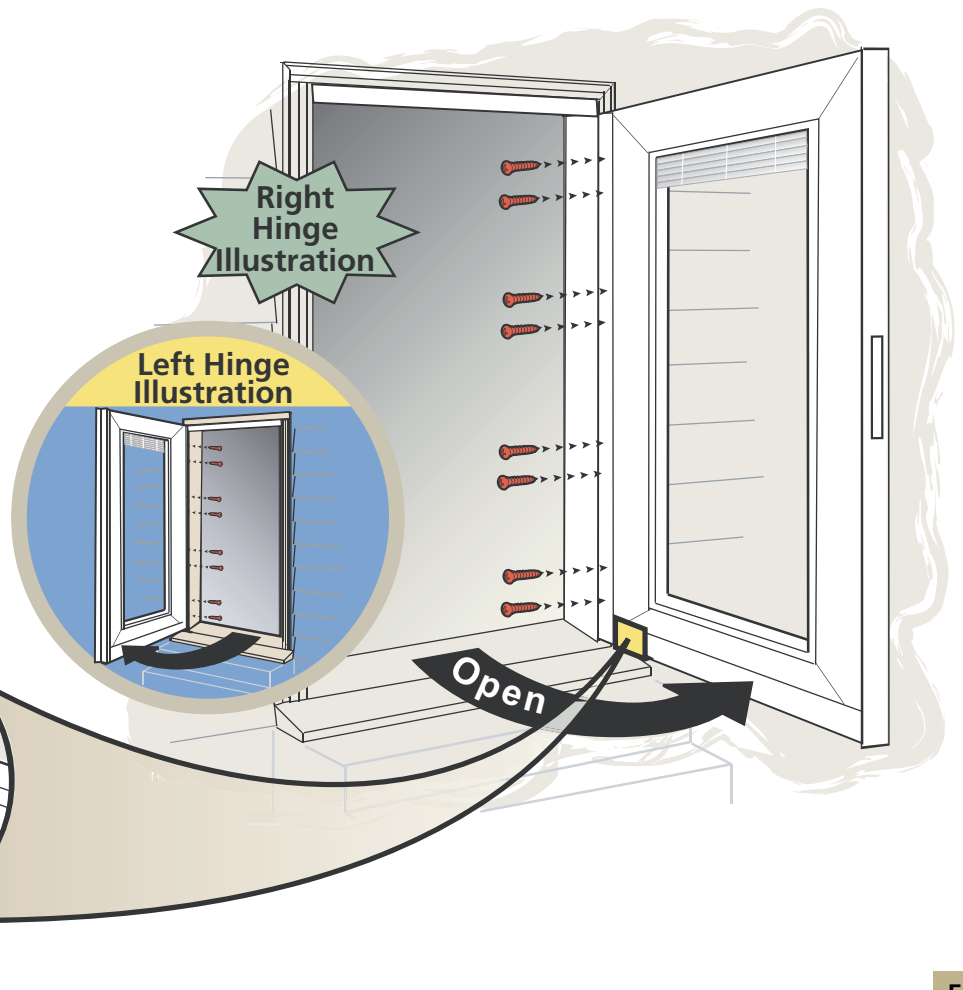

**11**

Remove and discard  
installation support block.

12

Position top mounting frame.

*Note: if you have interference with siding, remove the break-off tab with a pliers, then caulk along the back surface for protection from rain.*

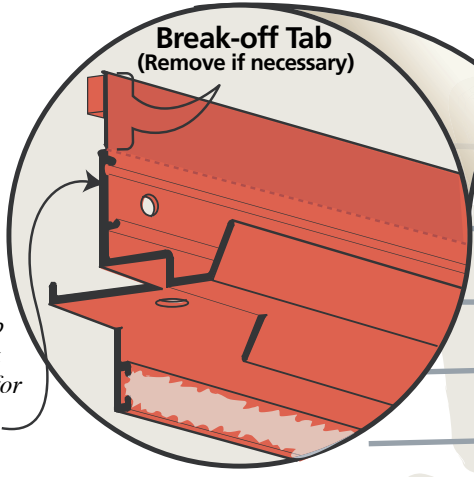

13

Close door.

Rest mounting frame on door.

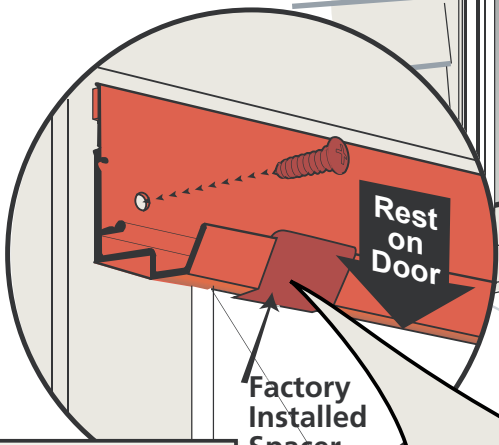

Predrill the two hole locations.

Secure with screws.

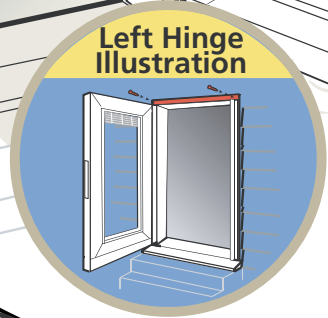

Right Hinge Illustration



<p>Drill 3/32" Pilot Holes</p> 	<p>Qty. 2 "Mounting Frame Screw Bag" unpainted #6 x 1" Pan Head</p> 
---	---

14

Remove the two spacers.

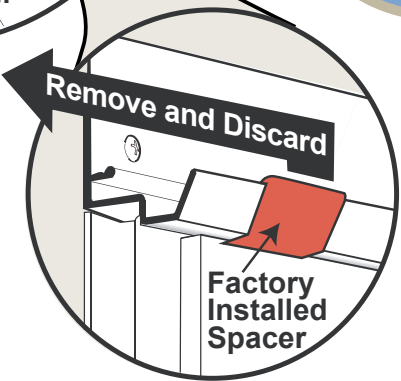



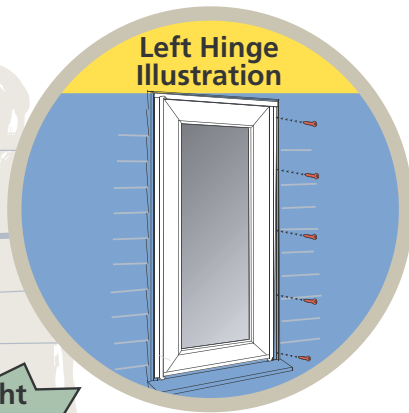
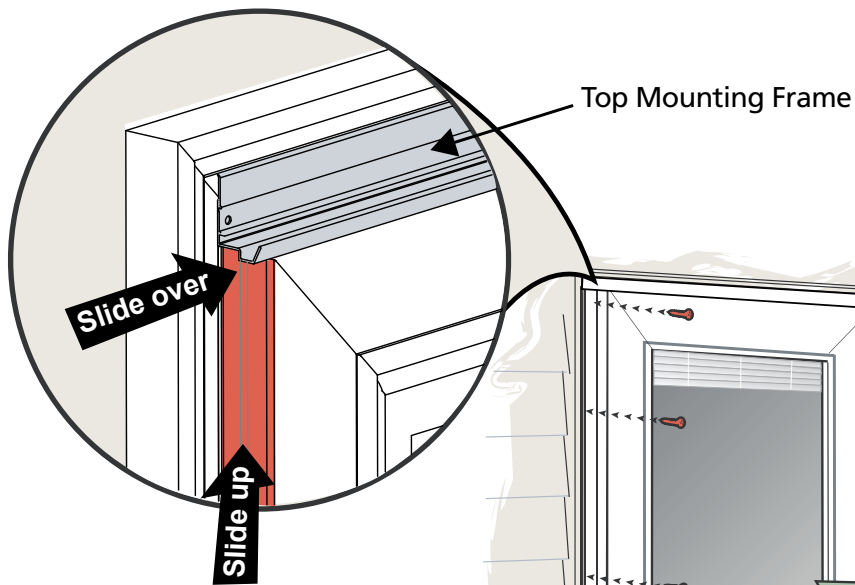

**15** Slide the latch side mounting frame up tight against top mounting frame, then slide over tight against notch in top mounting frame. Align outside edge of latch mounting frame parallel with the door. Verify that the door closes freely without hitting the latch mounting frame.

Predrill the five hole locations.  
Secure with screws.

Drill 3/32" Pilot Holes

**Qty. 5**  
"Mounting Frame Screw Bag"  
unpainted  
#6 x 1" Pan Head

**16** Install your handleset.

**a** The handle template is pre-applied to the door. Drill holes using instructions on template. Remove template after drilling.

**b** Insert the lock body so the flat side of the live bolt faces the outside of the door.

**c** Refer to handle instructions in Select® hardware kit (skip Step 9 in handle instructions). *Select hardware kit sold separately.*

**d** Once handle is installed, continue with step 17 on page 8.

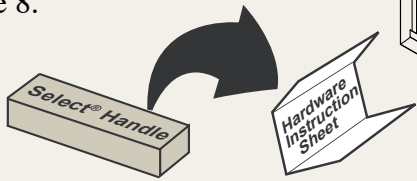
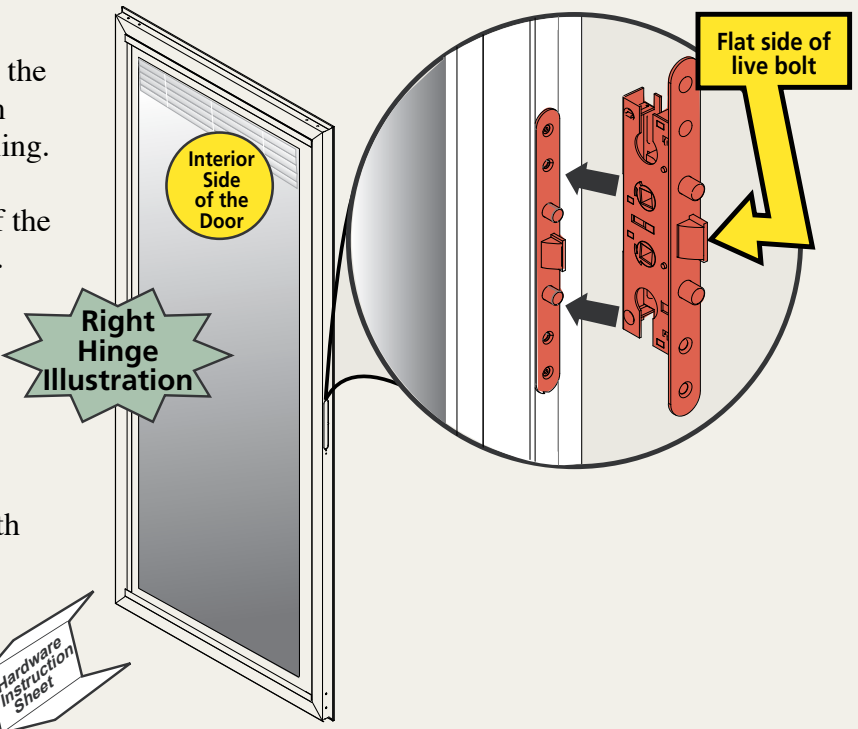

- 17** Remove the two pins (shown in red) from the closer bases and discard.

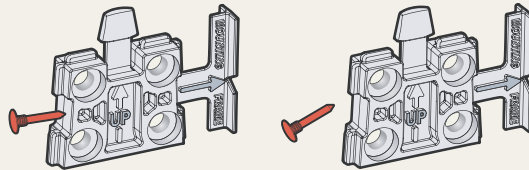

- 18** Determine which side to install the closers.  
[Right versus Left].

**LEFT HINGE** Install Closers on this side.

**RIGHT HINGE** Install Closers on this side.

- 19** Align closer base arrow with small notch on mounting frame (install both top and bottom).

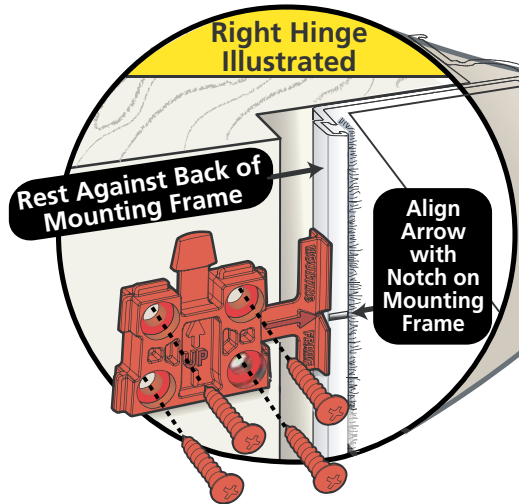

- 20** Predrill holes (3/32" bit).  
Secure with screws.

**Drill 3/32" Pilot Holes**

**Qty. 4 each**  
"Closer Screw Bag"  
Unpainted  
#10 x 1 1/2" Pan Head

- 21** Break off alignment tabs.

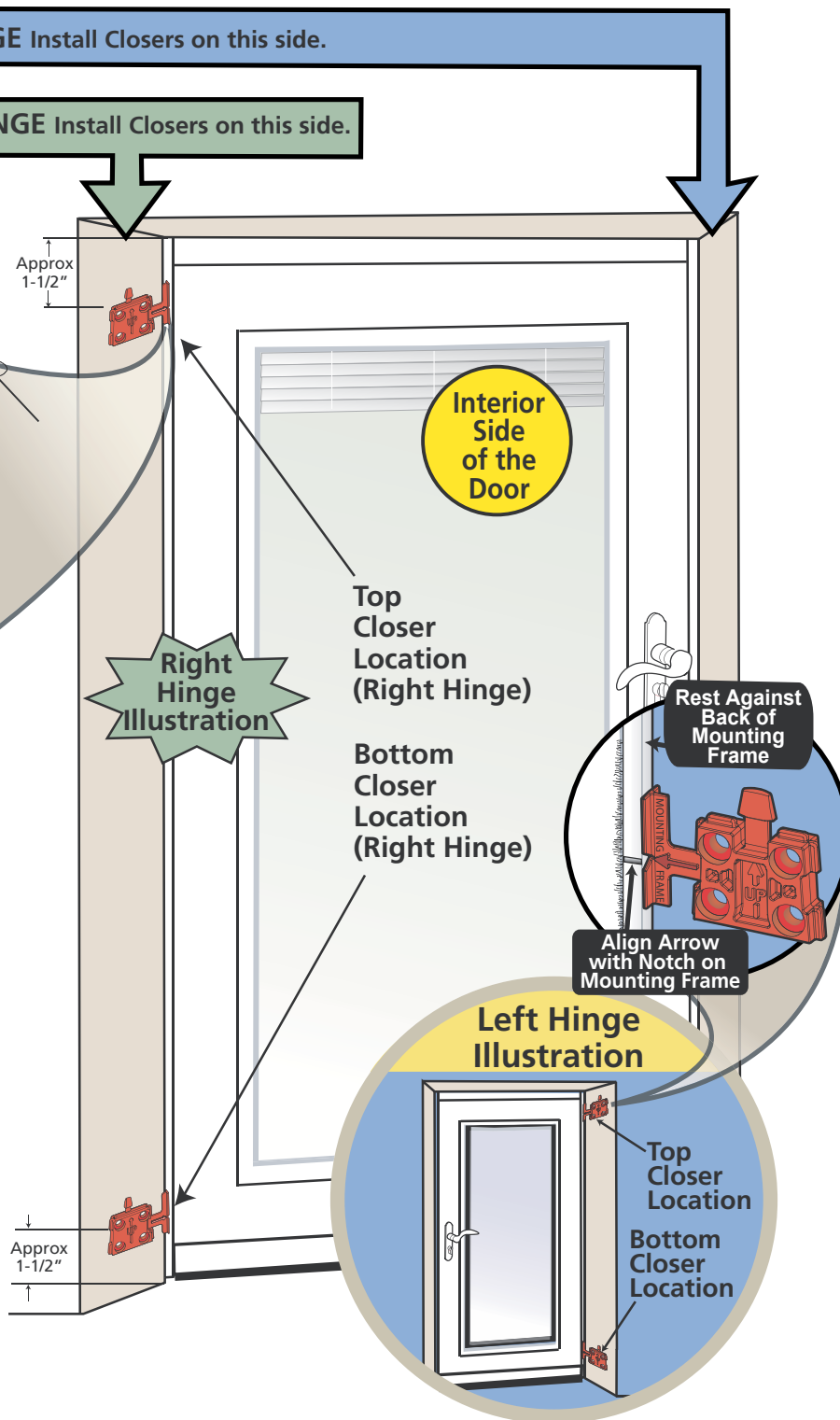
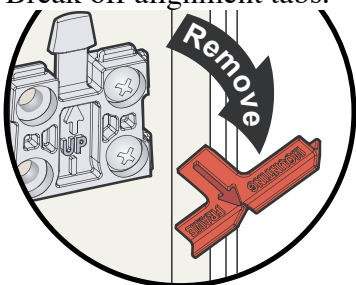



**22** Locate the top and bottom closers.

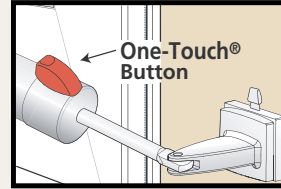
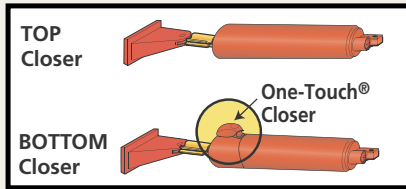

**To Use:**  
Open the door, then tap then button.

**To Close:**  
Nudge the door open slightly.

**23** Slide top and bottom closers onto their bases.

Rotate bottom closer as shown.

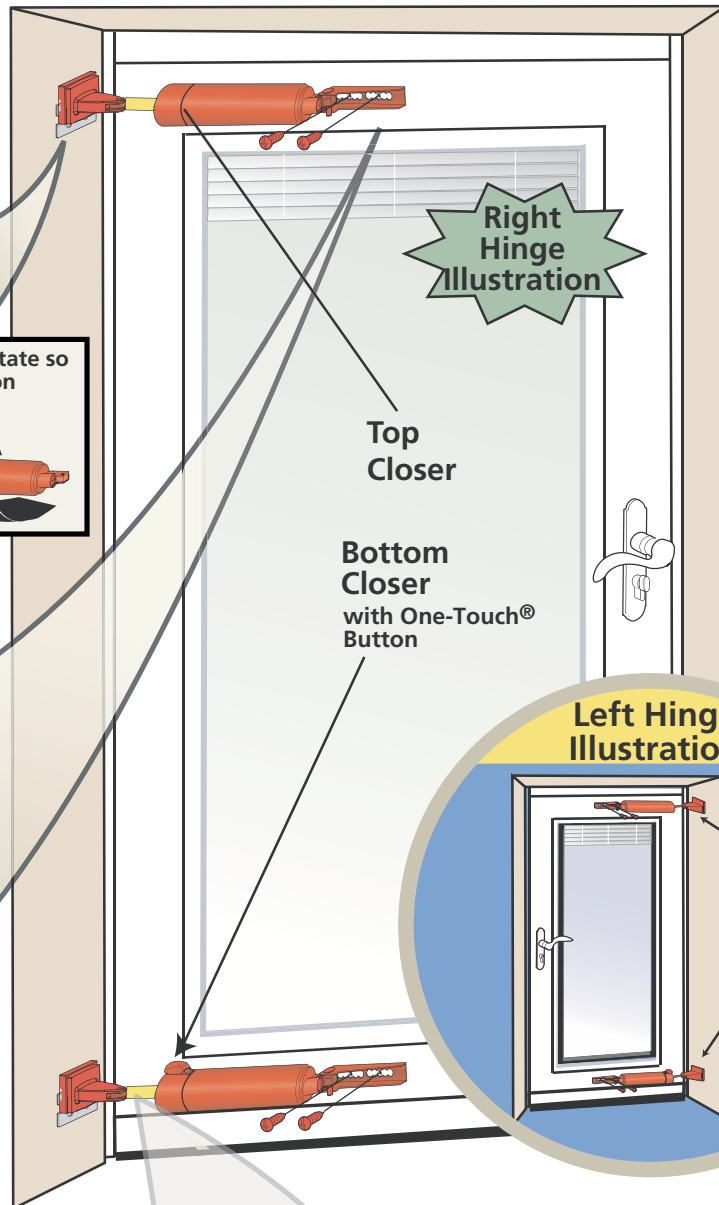
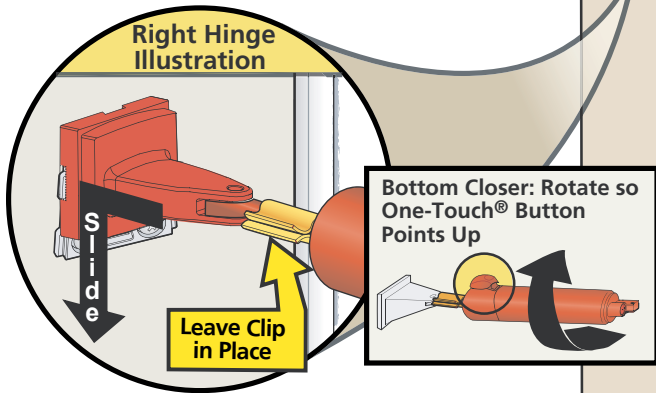

**24** Pin door bracket onto closer assembly.

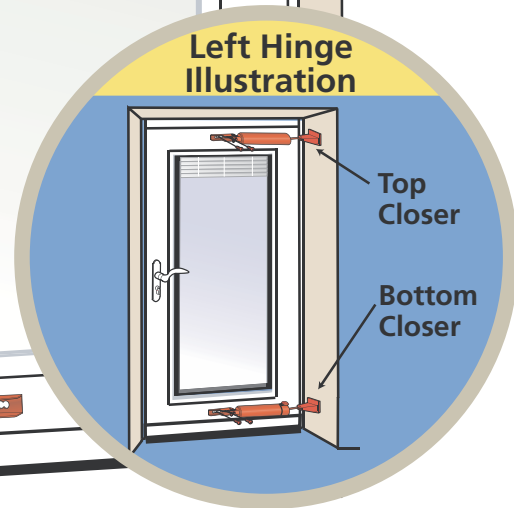
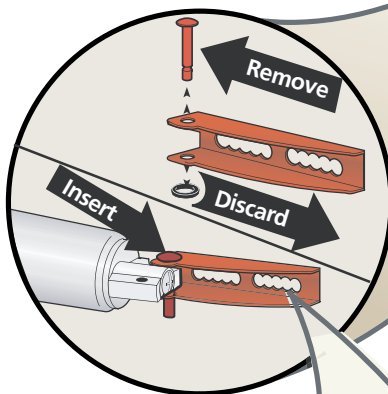

**25** Close door and position closer horizontally. Pre-drill 1/8" holes, then secure door bracket with screws.

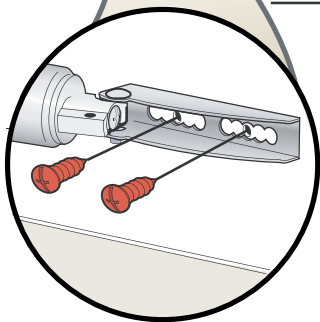

**26** Discard clips (top and bottom).



**27** Adjust closer speed with adjustment screw.

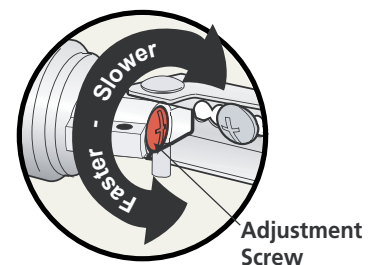

**Qty. 2 each**  
"Closer Screw Bag"  
color matched to door  
#10 x 5/8" Pan Head

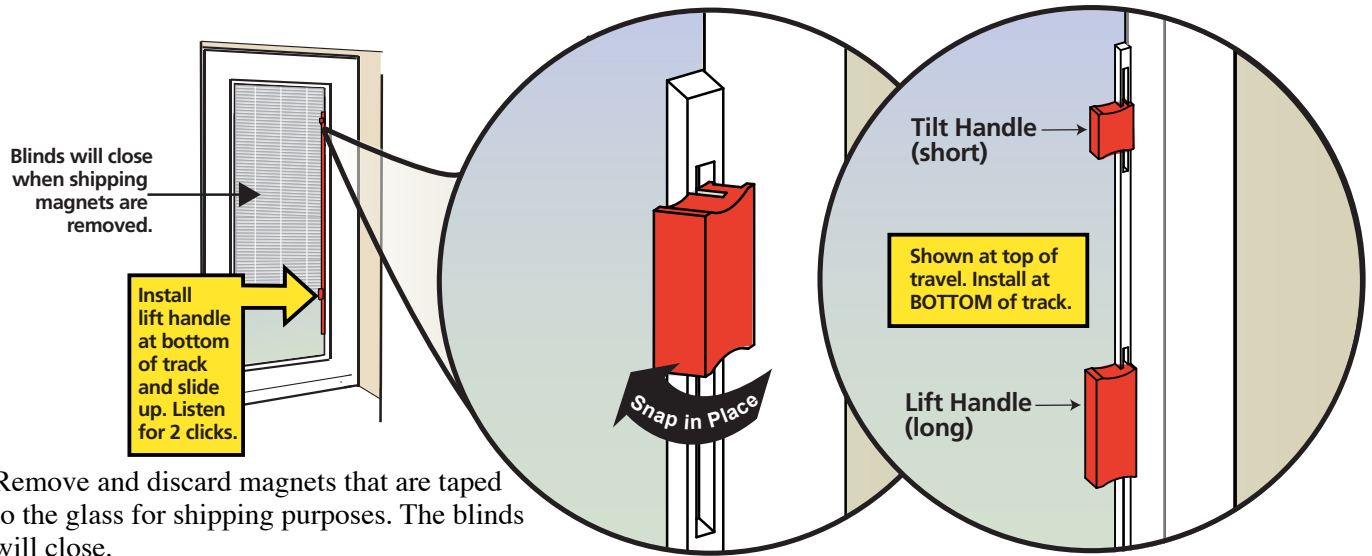

**28** Remove and discard magnets that are taped to the glass for shipping purposes. The blinds will close.

Insert tilt and lift handles at an angle **near the bottom of the track** and snap into place (moderate pressure may be required). Slide lift handle upward until you hear a soft click. Continue sliding up until you hear a loud click. The blinds are now operational.

**29** Close door.  
Adjust bottom expander to lightly contact the sill.  
Secure with screws from step 6, page 4.

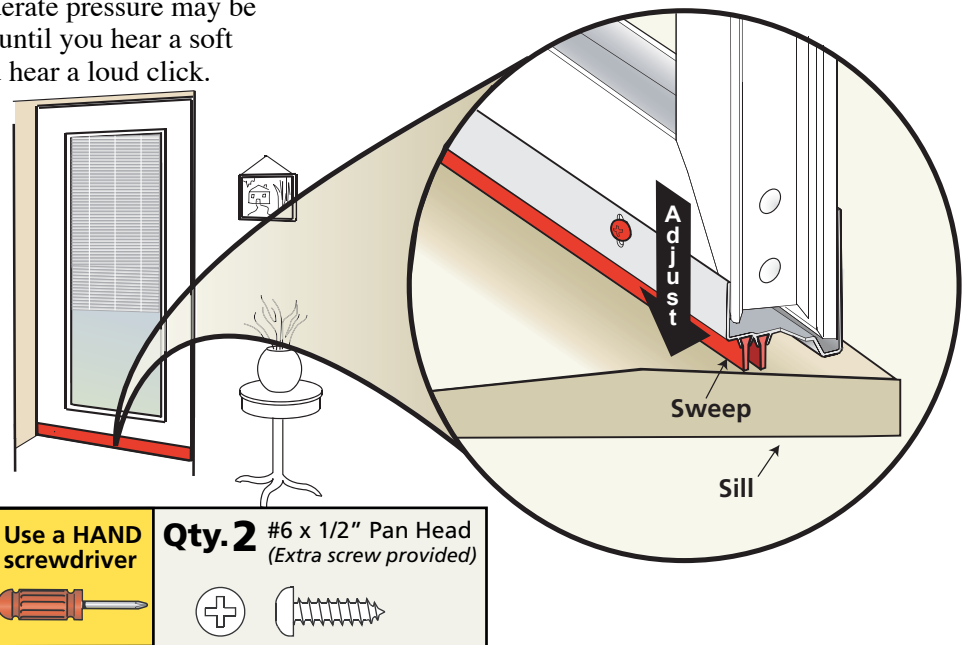

**30** Install screw cover strips (1 Horizontal, 2 Vertical).

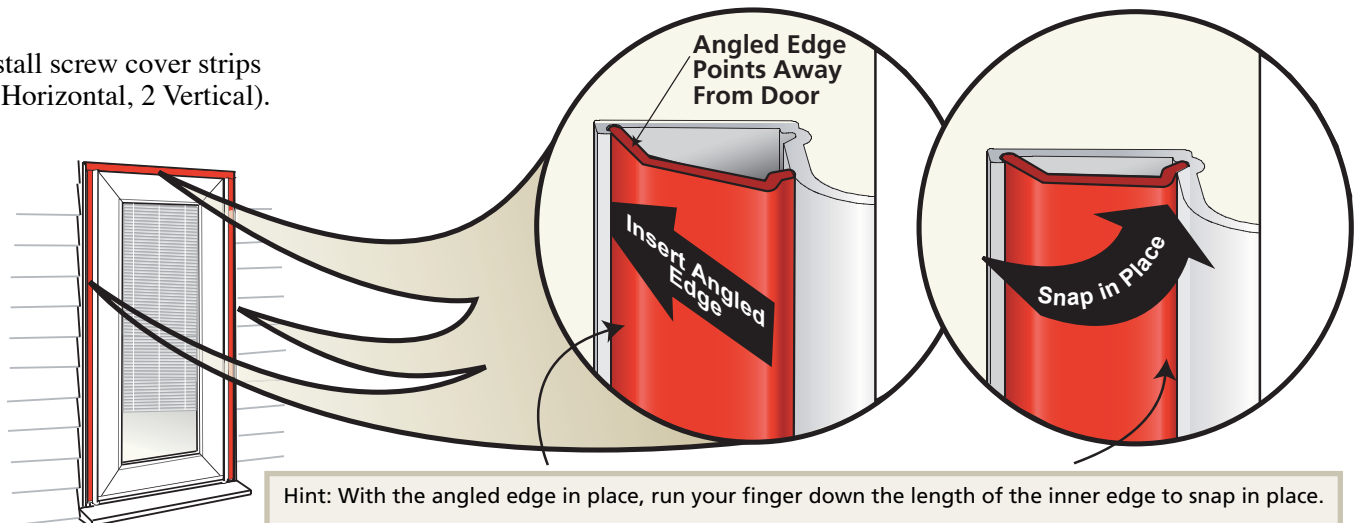

**Finished** with the installation. See page 11 for care and maintenance.

## Care and Maintenance

### Door Cleaning

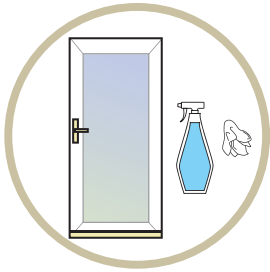

Use a soft cloth with any household grease-cutting cleaner to clean the door.

**PLEASE NOTE:** Thin marks on the painted surfaces of the door can be removed using turpentine and light rubbing with a clean cloth.

**IMPORTANT:** DO NOT use brass polish or steel wool on the bottom expander—Use a household grease-cutting cleaner or a mild soap and water solution.

### Glass Cleaning

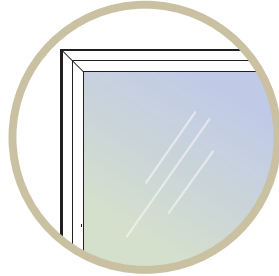

Routine Cleaning: Use any household glass cleaner.

### Handle Cleaning

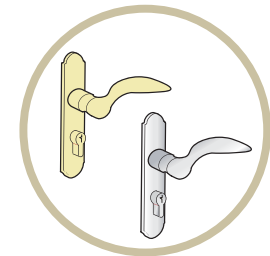

Routine Cleaning: Use a soft cloth with a mild soap and water solution to clean the surfaces.

Apply a high quality, non-abrasive automobile wax to polish.

Note: DO NOT use ammonia-based cleaners on brass or other metallic finish handles.

### Cleaning & Refinishing Damaged Brass

If your Pella® door includes a solid brass handle, the brass is polished and sealed with a clear coating by the manufacturer. Should the finish be accidentally damaged by an abrasive or sharp object, it will succumb to a natural oxidation process that occurs when the elements contact unprotected brass. Brass has an enduring quality, in that it can be refurbished to its original polished finish again and again by using a quality brass polish and a soft cloth. Do not clean the bottom expander in this manner - see door cleaning above.

1. Remove the hardware from the door so the finish of the door will not be affected. See the hardware instructions for removal.  
**NOTE:** you may be able to leave the hardware in place on the door when polishing the handle only – make certain to completely mask off all areas around the handle before starting. If polishing the key cylinder, protect the internal mechanism by covering the opening with tape.
2. Use a quality brass polish or cleaner to clean the brass - follow the product's directions and cautions. Note: Firm rubbing may be necessary to loosen the coating on the brass.
3. Reseal the brass per instructions below.
  - a. Use the properties from the brass polish you used to clean the brass. (Easiest method, but requires more frequent polishing.)
  - b. Apply a high quality, non-abrasive, polymer-based automobile wax to seal the surface.
  - c. Apply a new clear coat with a clear lacquer spray - follow the product's directions. (Most difficult, but lasts the longest.)

**PLEASE NOTE:** If you removed the hardware from the door, lubricate any internal workings with a spray lubricant. Re-install the hardware on the door. See the hardware instructions for installation.

# Troubleshooting Guide

If you have a question that you do not see listed here, or have not been able to resolve through your Pella® Owner's Guide and Installation Manual, call one of our customer service representatives toll-free at 1-800-374-4758.

Common Questions	Probable Causes	Suggested Solutions
Door does not open or close properly	Entryway framing is out or square/plumb or frame is warped	1. Verify the entryway framing and shim as necessary. [see page 2]
	Closer(s) out of position or adjustment	1. Remove the adjustment screw from the closer(s), cycle the door a few times, then replace the screw. [see page 9, Step 27] 2. Adjust the position of the closer door bracket until the door operates properly. [see page 9, Step 25]
	Bottom Expander is out of position	1. Verify the expander is centered on the door—adjust if necessary. [see page 4] 2. Verify the expander is not too low—adjust as necessary. [see page 10, step 29]
	Header Frame is out of position	1. Verify header frame is centered and aligned in the opening—adjust as necessary. [see page 3, steps 1–3]
	Hinges are binding	1. Verify mounting frame screws are not over tightened—back off screws slightly. [See page 5, steps 9 and 10] 2. Verify entryway framing is not twisted or warped—shim or modify as necessary. 3. Verify hinge mounting frame is not twisted or bent —replace if necessary.
Blinds do not operate	Handle not installed properly	1. Verify that handles were slid to top of travel during installation. [see page 10, step 28]
Handle does not latch properly	Latch not hitting trim plate	1. Adjust the trim plate until the latch catches. [see separate hardware instruction]
	Closer is out of position	1. See "Closer(s) out of position" in the "Door does not open or close properly" question above.
Water between the storm door and entry door	Bottom Sweep is making a tight seal against the door sill	1. Open the storm door and notch up to 1/2" off the ends of the black vinyl sweep.

## Pella® Storm Doors Limited Warranty

Congratulations on choosing a Pella storm door to protect and beautify your home. This superior quality door has been designed to give you years of trouble-free service, and you are protected by this limited warranty:

Pella warrants to the ORIGINAL HOMEOWNER PURCHASER of this storm door that it will, without charge to the purchaser, provide parts or exchange, at its option, any door determined to be defective in material or workmanship for 20 years after the purchase date. The purchaser will be responsible for transportation charges. Should the door be determined to be defective in material or workmanship AFTER 20 years from the purchase date, the original purchaser may buy one new Pella storm door at 50% of the then-current manufacturer's suggested list price for as long as the original purchaser owns the home on which the door was installed. The purchase must be made directly from the factory, and all transportation charges are the responsibility of the purchaser.

Should the door be determined to be defective and the purchaser incurs a reinstallation cost within three years of the purchase date, he or she may be reimbursed for these costs up to a maximum of \$25.00, upon furnishing a copy of the invoice for the reinstallation costs.

As a condition of this warranty, it is required that the door be used for residential use only in an owner-occupied home, that it be installed properly as an operating door according to manufacturer's instructions, and that it not be altered in any way. For multi-unit housing applications, ask your dealer for a copy of the appropriate warranty or phone Pella's Customer Service Department at the phone number listed below. This warranty is not transferable.

To make a claim under this warranty, you should:

- Call our Customer Service Department at 1-888-646-5354 or write to Pella Warranty Service; 2333 Eastbrook Drive; Brookings, SD 57006 USA.
- Furnish original or a copy of the sales receipt or other documents showing the original purchase date and that you are the original purchaser of this door. Exchange is limited to supplying a replacement door of comparable size, style, and color and does not include cost of removal or installation except as noted.

The warranty on the latch set and air closer is one year, and any labor charges are not covered. This warranty excludes all damage to glass and screen. This warranty does not cover problems caused by improper storage, handling, installation, use, modification, or maintenance, by Acts of God or by accidents, including accidental glass breakage. It does not apply to normal wear or discoloration of finish; finish problems caused by mechanical damage or abrasion; normal effects of sun and weather, including acid rain, salt spray, or other corrosive elements; damage caused by severe wind; or damage caused by customer abuse or neglect. Oil-Rubbed Bronze is a living finish that will develop its own unique patina with use and is not covered under the Lifetime Finish Guarantee. Bright Brass, Antique Brass, Brushed Brass and Satin Nickel hardware is guaranteed not to tarnish and carries a lifetime finish warranty for as long as the purchaser owns their home.

### Blinds Sealed Between Insulating Glass — Five-Year (5-Year) Limited Warranty.

Pella warrants that the insulating glass (with blinds sealed inside) shall be free from premature failure or permanent obstruction of vision due to a failure of the glass seal (other than glass breakage) and that the between-the-glass blind shall be free from manufacturing defects in material or workmanship that significantly impairs its proper operation and function for five (5) years from the date of retail sale by an authorized dealer for as long as the original purchaser owns the home in which the door was initially installed, whichever is shorter.

THIS WARRANTY EXCLUDES ALL INCIDENTAL AND CONSEQUENTIAL DAMAGES. Nothing in this document shall give rise to or extend the period of any warranties implied under state or provincial law, and no implied warranty shall extend beyond the periods covered by this written warranty. Neither Pella Corporation nor any seller of Pella products will be responsible for incidental or consequential damages which may result from a product defect or malfunction. Some states do not allow the exclusion or limitation of incidental or consequential damages, so the above limitation or exclusion may not apply to you. This warranty gives you specific legal rights, and you may have additional rights which vary from state to state. Effective 7/2006.