

Multi-Slide and Large Sliding Patio Door – Site Preparation

These instructions will cover the necessary site preparations needed before starting the installation of a multi-slide or large sliding door system. Properly preparing the opening is critical to the performance and longevity of the door.

Due to the larger spans of multi-slide doors, it is recommended that a professional architect or structural engineer be consulted during the pre-planning of headers and wall construction.

Please read entire instruction completely before beginning.

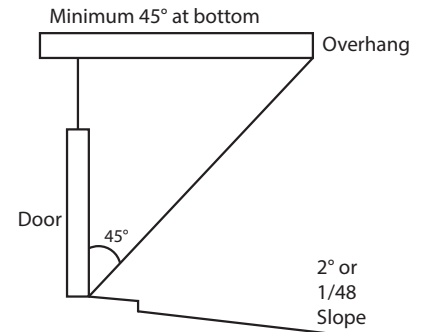
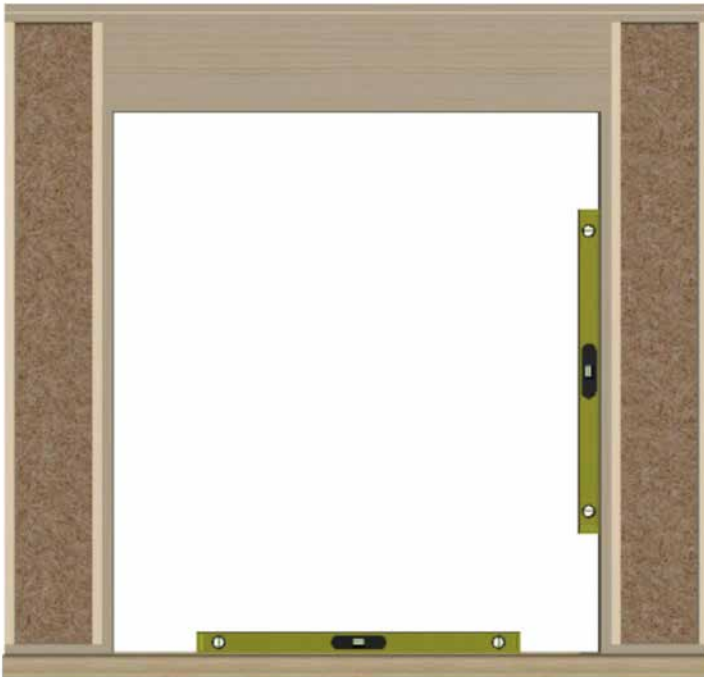

Multi-slide doors come in a wide array of configurations and sill types. Not all configurations and applications will be suitable for all environments. In general, it is highly recommended that Multi-Slide systems are installed in areas with sufficient overhangs as required to prevent water or air infiltration. The suggested overhang of the structure should match the height of the unit being installed. Failure to do so may result in structural damage to the surrounding area, finishes and/ or systems.

Safety Alert Symbol Reference: These symbols are intended to alert you to potential injury hazards and information. Obey all safety messages.

<p>COULD</p> <p>Result in:</p>	 <p>WARNING</p> <p>Major Injury/Death</p>	<p>COULD</p> <p>Result in:</p>	 <p>CAUTION</p> <p>Minor Injury</p>	<p>COULD</p> <p>Result in:</p>	 <p>NOTICE</p> <p>Product or Property Damage</p>	<p>COULD</p> <p>Result in:</p>	 <p>IMPORTANT</p> <p>Procedure and Product Info.</p>
---------------------------------------	---	---------------------------------------	---	---------------------------------------	---	---------------------------------------	--

 **WARNING**

Lead-based paint may be present in older homes, and the removal of windows and doors may cause this paint to be disturbed. To minimize exposure to lead-based paint dust, please consult www.epa.gov/lead for more information.

 **WARNING**

Doors can be extremely heavy. To avoid injury, use appropriate lifting techniques and adequate number of people to carry and install the product. Mechanical lifting assistance may be needed for larger panels and glass. Failure to do so can result in injury or damage to product or property.

Multi-Slide and Large Sliding Patio Door – Site Preparation

PREPARATION OF THE SILL

For proper water management it is required that multi-slide door systems be stalled with a sill pan in accordance with ASTM E2112. A rigid option is detailed below in Figure 1.

- It is the responsibility of the installer to verify the compatibility of installation materials. Special care must be taken to prevent galvanic reactions when installing in raw masonry or concrete.
- Sills pans should be installed continuous across the bottom of the opening and be integrated with the weather resistant barrier (WRB).
- Any shimming needed to level sill should be made under the sill pan. Sill height variance can only be a max of 1/16" across the width of the door. A laser level is recommended to insure tolerance requirements.
- Any fasteners that penetrate the sill pan must have sealant applied to the pre-drilled hole prior to fastening.
- Secure the sill pan into the opening with two 3/8" beads of sealant applied across the width of the sill opening. Beads should be located approximately 1" in from the interior and exterior with beads also located on the back dam and exterior drip flange (Figure1).

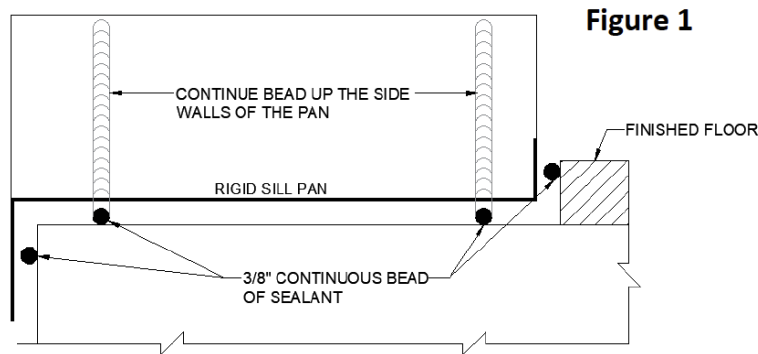
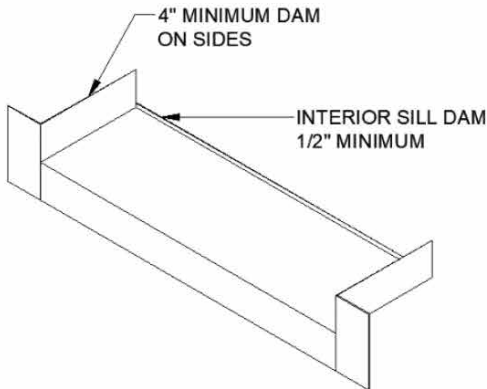
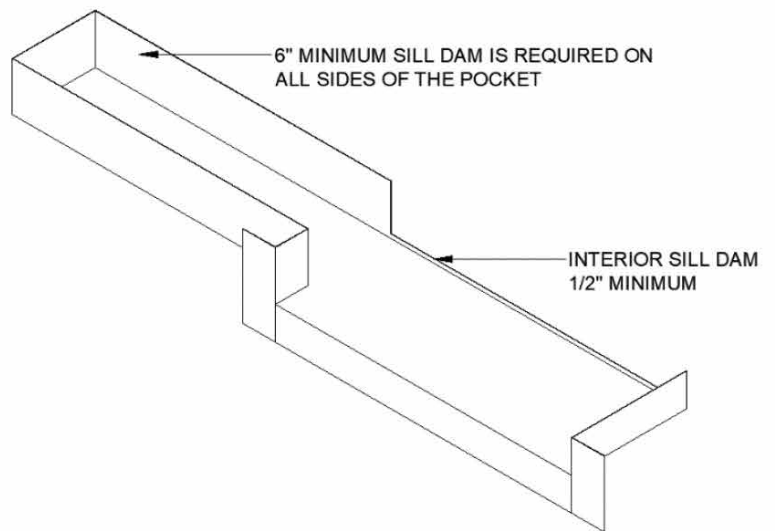

Figure 1

Figure 2



TYPICAL STACKED SILL PAN
(Type I Rigid Sill Pan)



TYPICAL POCKETING SILL PAN
(Type I Rigid Sill Pan)

Multi-Slide and Large Sliding Patio Door – Site Preparation

FRAMING FOR THE DOOR

Details included in these instructions provide only one example of a possible condition. Your conditions may vary. Consult with a professional architect or structural engineer for alternate framing details based on your specific conditions.

Framing for multi-slide door openings will vary based on the configuration (stacked or pocketing) and the number of tracks the door system has.

Header – Must be flat and designed to support the full load of the structure above and meet a deflection requirement of not more than 1/8" over the entire length of unsupported span. Header sag could cause panels not to operate properly.

Side Jamb – Must be plumb and true within 3/16". Side jamb surface must be continuous and solid with a minimum of 3" of substrate thickness for fastening.

Minimum Jamb Depth for Stacked Panel Configurations

Stacked Jamb Depths (Figure 3)		
Tracks	Jamb Depth w/ Nail Fin (A)	Jamb Depth w/o Nail Fin (B)
2 Tracks	6-15/16" (176)	8-3/16" (209)
3 Tracks	9-15/16" (252)	11-3/16" (285)
4 Tracks	12-15/16" (329)	14-3/16" (361)
5 Tracks	15-15/16" (405)	17-3/16" (437)

Figure 3

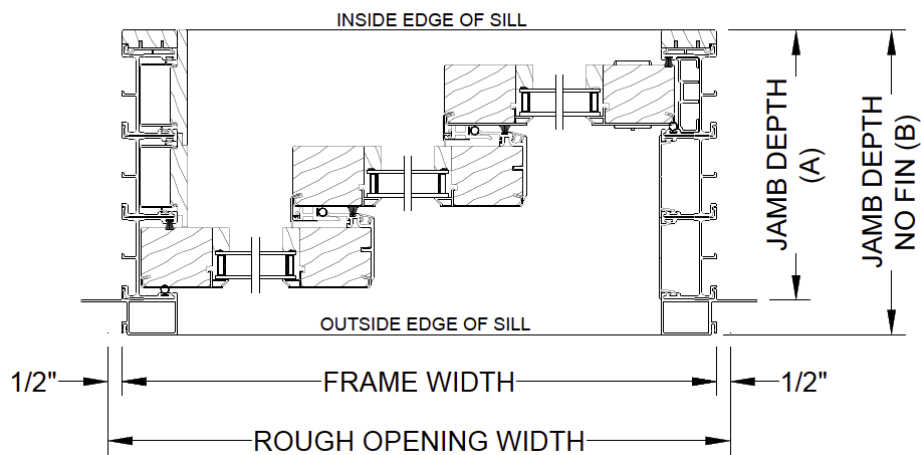

Multi-Slide and Large Sliding Patio Door – Site Preparation

FRAMING FOR THE DOOR (continued)

Minimum Jamb Depth for Pocket Configurations

Pocket Jamb Depths (Figure 4)			
Tracks	Pocket Depth (A)	Jamb Depth in Pocket (B)	Jamb Depth Out of Pocket (C)
1 Track	6" (153)	4-7/8" (124)	5-3/16" (132)
2 Tracks	8" (203)	6-7/8" (175)	8-3/16" (209)
3 Tracks	11" (280)	9-7/8" (251)	11-3/16" (285)
4 Tracks	14" (356)	12-7/8" (327)	14-3/16" (361)
5 Tracks	17" (432)	15-7/8" (404)	17-3/16" (437)

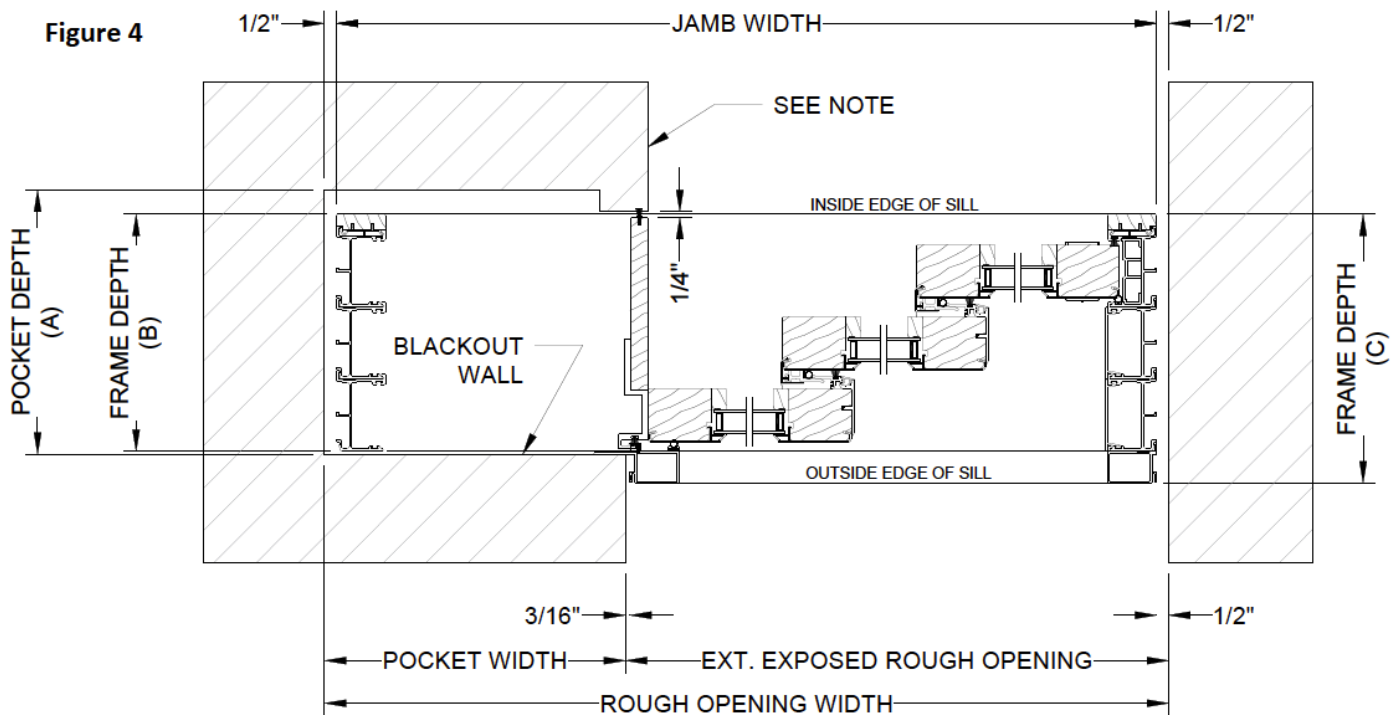

IMPORTANT NOTE: Interior pocket wall must be framed after the door frame is installed. The return of the interior pocket wall to the door pocket closure panel needs to leave a 1/4" gap for weatherstrip contact.

Multi-Slide and Large Sliding Patio Door – Site Preparation

FRAMING FOR THE DOOR (continued)

Pocket Door Framing

NOTE: Framing shown for the purpose illustrating the pocket cavity. Actual framing may vary. Interior pocket wall not shown.

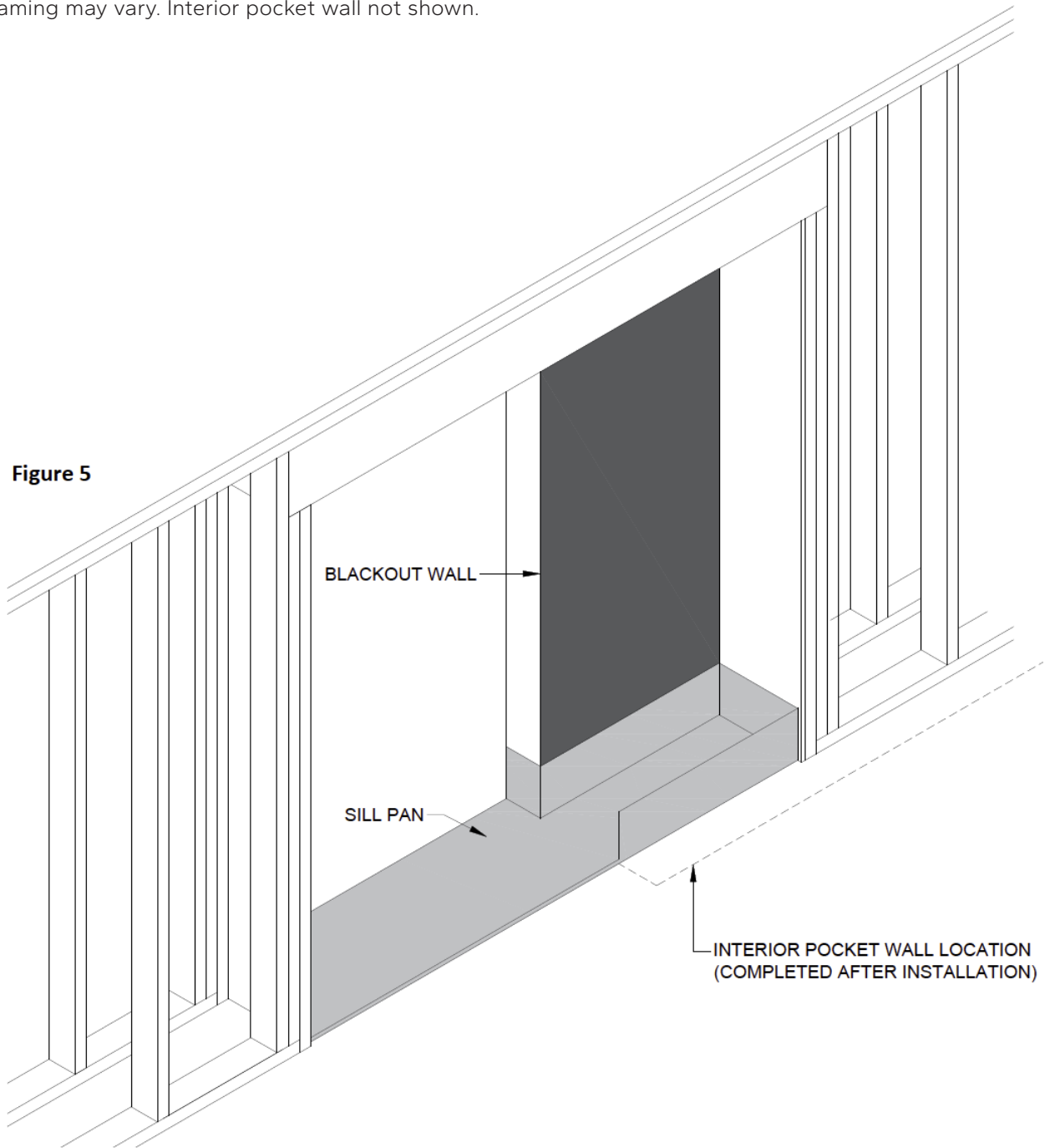

Multi-Slide and Large Sliding Patio Door – Site Preparation

PREPARATION OF AN OPENING

Verification of Size

- Make sure the door will fit in the rough opening. Measure the opening width and height in three separate places to ensure the framing is not bowed. Opening size should be 1" larger in width and 1/2" larger in height than the door frame.
- Verify the opening is plumb, level and square.
- Make sure the sill area is free from debris.

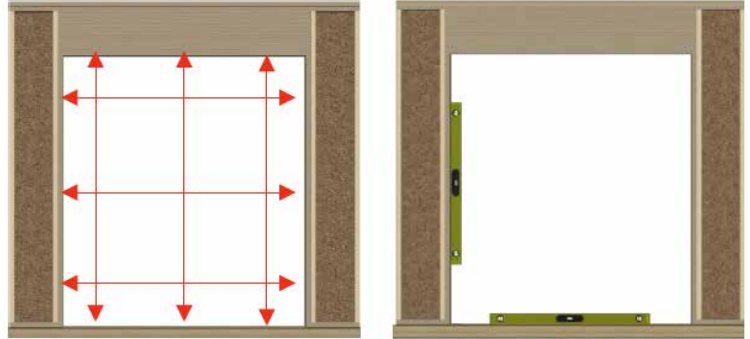

Rough Opening Preparation (WRB installed)

- Cut the Weather Resistant Barrier (WRB) even with the opening horizontally at the head and sill. At each side cut the WRB 2" past the jambs. This will allow the nailing fin to mount directly to the sheathing.
- At the head make a 45 degree 6" long cut at each corner. Fold the WRB flap up at the head and temporarily tape it above the opening.

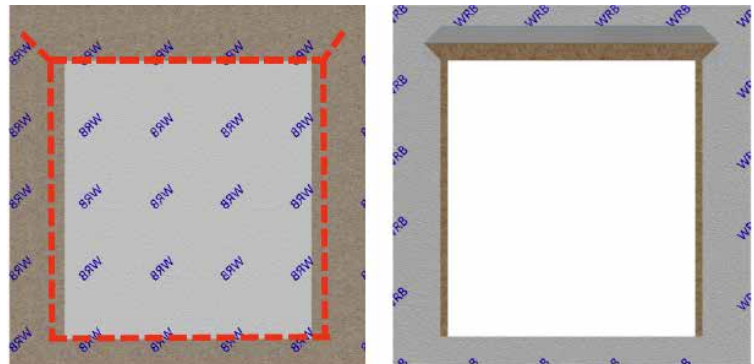

Multi-Slide and Large Sliding Patio Door – Site Preparation

RETRACTABLE SCREEN STYLES

For proper integration of a retractable screen system, the door site preparation must accommodate the frame of the screen. The following details show the recommended location for the placement of the retractable screen frame.

Retractable screen systems can be installed directly on the subfloor or recessed in the subfloor. This preference must be specified when ordering for the screen height to be sized properly. In addition, the standard wept sill on Weather Shield multi-slide doors is available with three heights of interior sill stops. The height of the screen frame will be dependent on the height of the sill stop and the preference for installing flush or recessed.

Figure 6 Screen Frame Direct on Subfloor

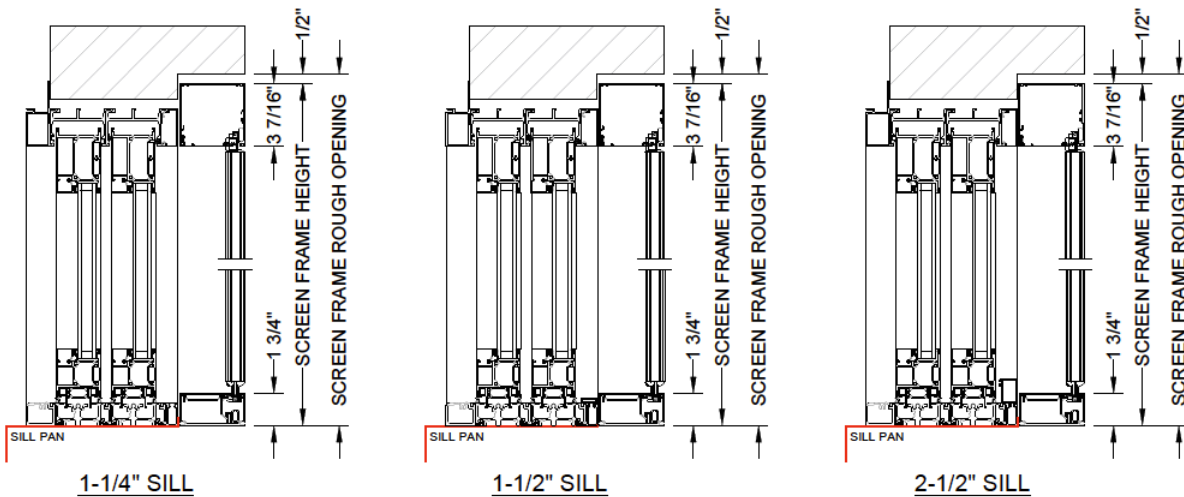
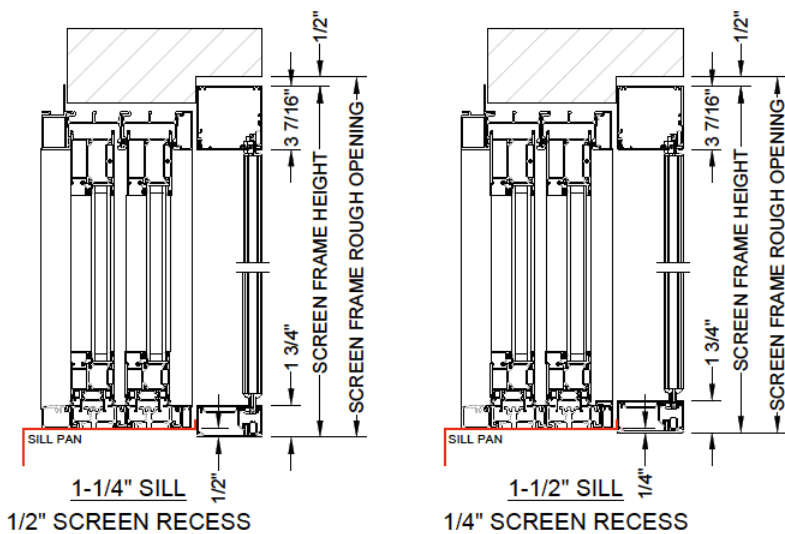

Figure 7 Screen Recessed in Subfloor



Multi-Slide and Large Sliding Patio Door – Site Preparation

RETRACTABLE SCREEN STYLES (continued)

Figure 7 Single Direction (OXX)

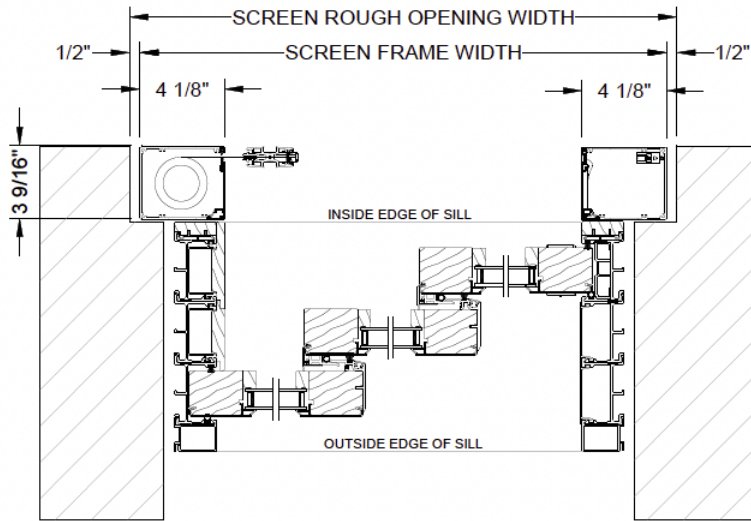
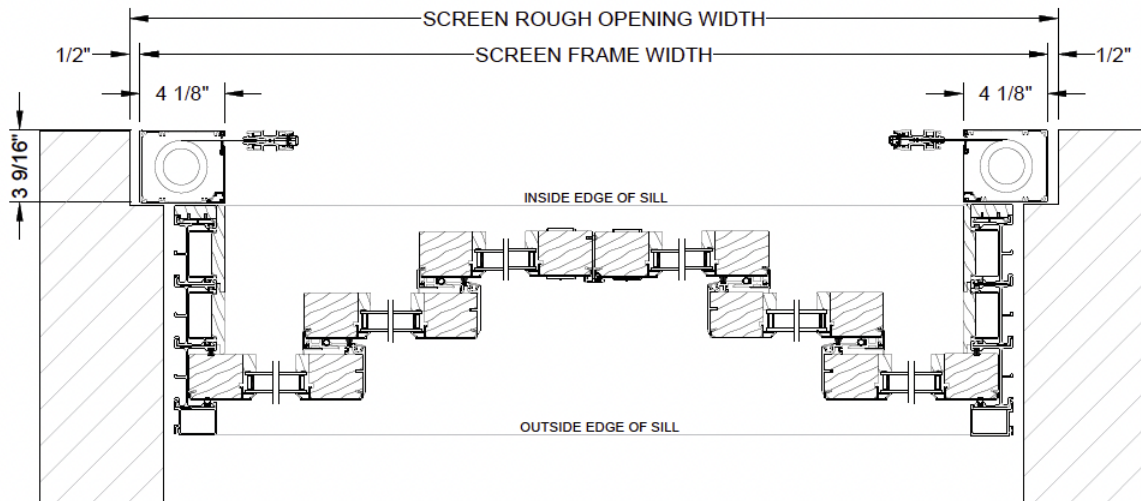

Figure 8 Bi-Parting (OXX-XXO)



Multi-Slide and Large Sliding Patio Door – Site Preparation

RETRACTABLE SCREEN STYLES (continued)

Figure 9 Single Direction Pocketing

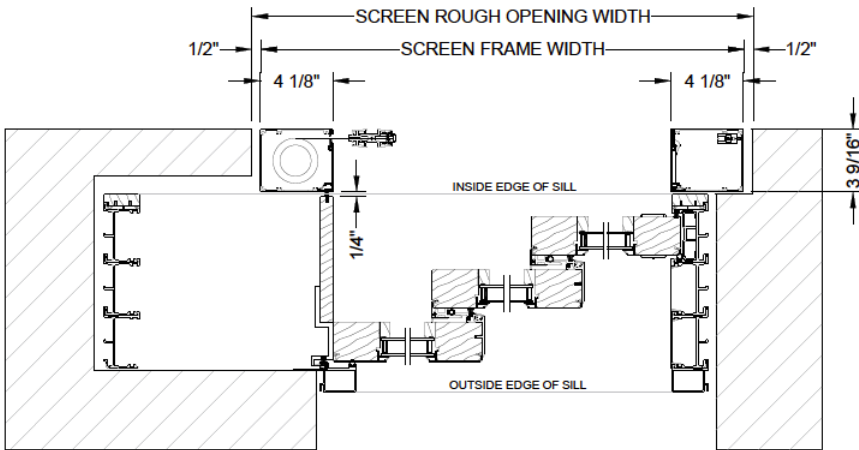

Figure 10 Bi-Parting Pocketing

