

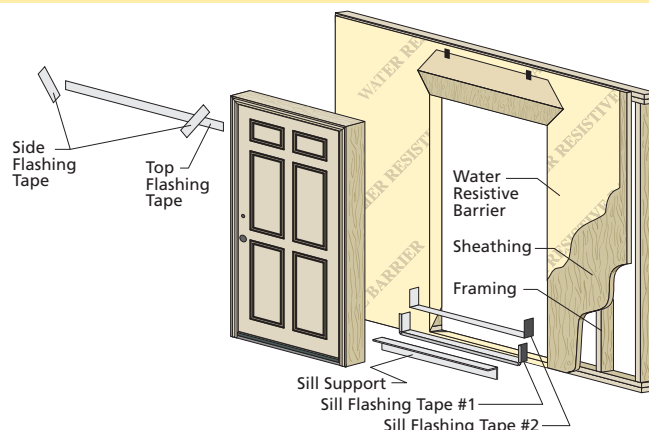

INSTALLATION INSTRUCTION – PREMIUM WOOD ENTRY DOOR (SINGLE DOORS AND SINGLE DOORS WITH SIDELIGHTS)







Always read the Pella® Limited Warranty before purchasing or installing Pella products. By installing this product, you are acknowledging that this Limited Warranty is part of the terms of the sale. Failure to comply with all Pella installation and maintenance instructions may void your Pella product warranty. See Limited Warranty for complete details at <http://warranty.pella.com>.



Installation Instructions for Typical Wood Frame Construction.

These instructions were developed and tested for use with typical wood frame wall construction in a wall system designed to manage water. **These instructions are not to be used with any other construction method.** Installation instructions for use with other construction methods may be obtained from Pella® Corporation, a local Pella retailer or by visiting <http://www.pella.com>. Building designs, construction methods, building materials, and site conditions unique to your project may require an installation method different from these instructions and additional care. Determining the appropriate installation method is the responsibility of you, your architect, or construction professional.

YOU WILL NEED TO SUPPLY:

- Cedar/impervious shims/spacers (12 to 20) 
- 10d galvanized finish nails or #8 x 3" corrosion resistant wood screws 
- Pella® SmartFlash™ foil backed butyl window and door flashing tape or equivalent 
- Closed cell foam backer rod/sealant backer (12 to 30 ft.) 
- Great Stuff™ Window and Door Insulating Foam Sealant by the Dow Chemical Company or equivalent low pressure polyurethane window and door foam - DO NOT use high pressure or latex foams. 
- High quality exterior grade polyurethane sealant (2 to 3 tubes per door) 
- Pella aluminum sill support or 2" x 4" wood blocking
- Interior trim and/or jamb extensions (15 to 40 ft.)
- Aluminum head flashing (doors with brickmould only)

TOOLS REQUIRED:

- Tape measure 
- Level 
- Square 
- Drill 
- Stapler 
- Scissors or utility knife 
- #2 and #3 Phillips screwdrivers 
- Hammer 
- Sealant gun 

Installation will require two or more persons for safety reasons.

REMEMBER TO USE APPROPRIATE PERSONAL PROTECTIVE EQUIPMENT.

1 ROUGH OPENING PREPARATION

- A. **Verify the opening is plumb and level.**

Note: It is critical that the bottom is level.

- B. **Determine the finished floor height.** If the finished floor height will be more than 1" higher than the surface the door will be set on, add a filler board under the sill. The top of the filler board should be within 1" of the finished floor height.

- C. **Verify the door will fit the opening.** Measure all four sides of the opening to make sure it is 3/4" larger than the door in width and 1/2" larger in height. Measure the opening width in several places to ensure the studs are not bowed (1C).

Note: 1-1/2" or more of solid wood blocking (studs) is required around the perimeter of the opening. Fix any problems with the rough opening before proceeding.

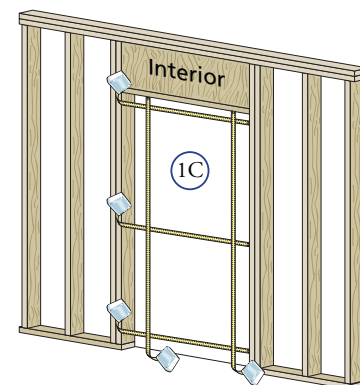
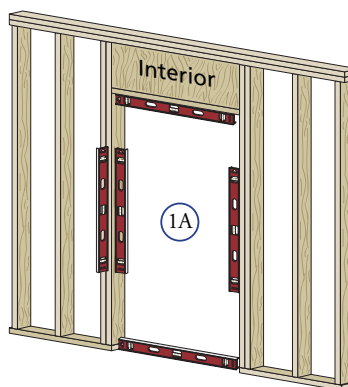

D. **Cut the water resistive barrier, if applicable (1D).**

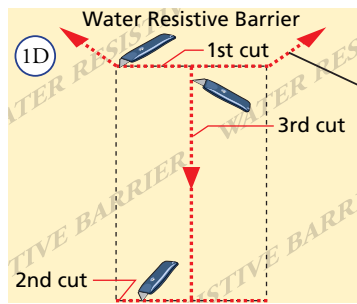

4th cut:
Make a 6" cut up
from each top corner
at a 45° angle to allow
the water resistive barrier
to be lapped over the fin
at the head of the door.

E. **Fold the water resistive barrier (1E).** Fold side and bottom flaps into the opening and staple to inside wall. Fold top flap up and temporarily fasten with flashing tape.

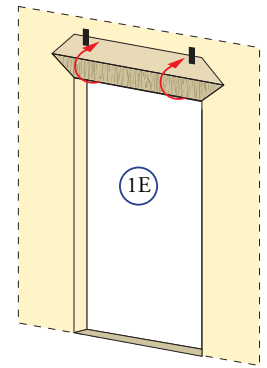

F. **Apply sill flashing tape #1.** Cut a piece of flashing tape 12" longer than the opening width. Apply at the bottom of the opening as shown (1F) so it overhangs 1" to the exterior.

Note: The tape is cut 12" longer than the width so that it will extend 6" up each side of the opening.

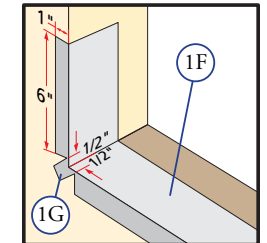

G. **Tab the sill flashing tape and fold.** Cut 1" wide tabs at each corner (1/2" from each side of corner) (1G). Fold tape to the exterior and press firmly to adhere it to the water resistive barrier.

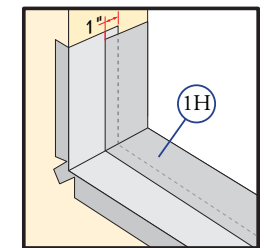

H. **Apply sill flashing tape #2.** Cut a piece of flashing tape 12" longer than the opening width. Apply at the bottom, overlapping tape #1 by at least 1". DO NOT allow the tape to extend past the interior face of the framing (1H). If the wall depth is greater than 5", add a third piece of flashing tape. The flashing tape should come to within 1" of the interior face of the framing.

Note: The flashing tape does not need to extend all the way to the interior of the framing.

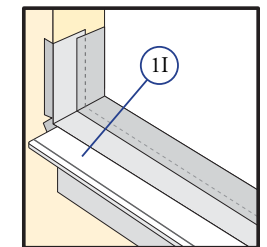

I. **When required for adequate sill support,** attach the optional aluminum sill support or wood blocking to the exterior of the box plate to support the edge of the door sill (1I). Place the sill support flush with the subfloor.

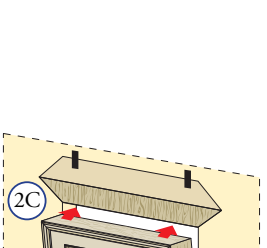

2 SETTING AND FASTENING THE DOOR

A. **Remove packaging from door.** DO NOT open the door until it is secured in the opening. If the panel was packaged separately, DO NOT install the panel until Step 2E.

B. **Place three 3/8" beads of sealant along the bottom of the opening.** The first bead should be approximately 3/4" from the exterior of the rough opening (2B). The second bead should be placed so it is under the wood interior threshold of the door. Place a third bead of sealant in the groove of the sill support or 1/4" from the exterior edge of the wood blocking.

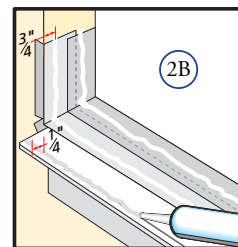

TWO OR MORE PEOPLE WILL BE REQUIRED FOR THE FOLLOWING STEPS

C. **Insert the door from the exterior of the building. DO NOT slide the bottom of the door into the opening (2C).** (Sliding will damage the sealant lines.) Place the bottom of the door at the bottom of the opening, then tilt the top into position. Center the door between the sides of the opening to allow clearance for shimming. Insert a #8 x 3" corrosion resistant flat head screw through the mid point of the hinge jamb, into the structural framing.

For In-swing units with sidelights: Pre-drill a 1/8" hole and insert a #8 x 3" corrosion resistant flat head screw in the exterior sidelight jamb on the hinge side of the door.

Note: The screws are used to hold the door in place while shimming it plumb and square. Pre-drilling screw holes in the frame is recommended when using screws to fasten the door to the framing.

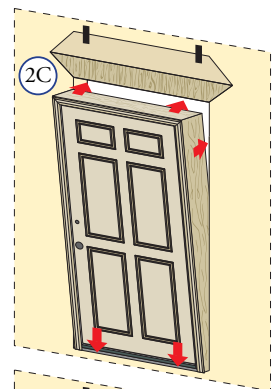

D. **Plumb and square door.** Place shims at each hinge location between the door and the sides of the opening. Insert shims in other locations as needed starting up 6" from the bottom of the door to square it in the opening (2D). Make sure that the clearance between the door panel and door frame is equal. Shim above the mullion joint of doors with sidelights.

Note: DO NOT over shim. (DO NOT bow the jambs inward.)

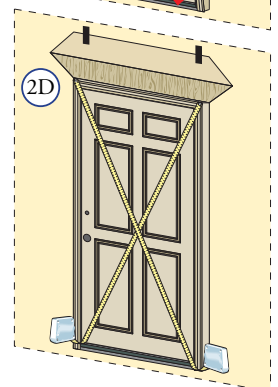

E. Carefully open the door panels and remove all shipping spacers.

Note: If the door panel was packaged separately, remove it from its packaging and install it in the frame by aligning the knuckles on the frame and panel hinge leaves, and insert the hinge pin completely.

F. **For single doors:** Insert a long screw (provided) into the open screw hole in the top hinge (2F).

For units with sidelights: Approximately 6" from the top of the hinge side sidelight exterior jamb, pre-drill a 1/8" hole and insert a #8 x 3" corrosion resistant flat head screw. Make sure the screw passes through the shims and into the structural framing.

G. **Check for even contact between the door panel and weatherstrip** on the sides and the top (2G). If space exists between the weatherstrip and the door panel at the top, move the bottom of the lock side out. If space appears at the bottom, move the top of the lock side out.

H. **Drive a 10d galvanized finish nail or 3" screw through the frame lock jamb, approximately 6" from the top and bottom,** through the shims and into the structural framing.

For units with sidelights: Approximately 6" from the top of the lock side sidelight exterior jamb, pre-drill a 1/8" hole and insert a #8 x 3" corrosion resistant flat head screw. Make sure the screw passes through the shims and into the structural framing.

I. **For single doors:** Insert a long screw (provided) into the open screw hole in all the remaining hinges.

For units with sidelights: Pre-drill a 1/8" hole and insert a #8 x 3" corrosion resistant flat head screw directly above or below each shim on the hinge side sidelight exterior jamb (minimum three screws for 6' 8" units or four screws for 8' 0" units).

J. **Insert a 10d finish nail or 3" screw** into the lock jamb (or lock side sidelight exterior jamb if applicable) directly above or below each shim.

For units with sidelights: Pre-drill a 1/8" hole and insert a #8 x 3" corrosion resistant flat head screw directly above or below each shim on the hinge side sidelight exterior jamb (minimum three screws for 6' 8" units or four screws for 8' 0" units).

K. **For units with sidelights:** Insert a 10d finish nail or 3" screw into the head jamb of the door frame in each of the corners where it meets the sidelight.

L. **Check door operation.** Open and close the door to check for proper operation.

Note: If there are any problems with the operation, recheck and adjust the reveal. Plastic "E" shaped shims may be placed behind the hinge leaves to adjust the reveal between the door panel and the frame.

M. **If needed, the height of the threshold can be adjusted** to achieve appropriate contact with the door sweep. Using a #3 Phillips screwdriver, turn the adjustment screws clockwise to lower the threshold, and counter-clockwise to raise the threshold (2M).

N. **Install the adhesive corner seal pads.** The raised fin of the corner pad needs to be tucked under the weatherstrip (2Na) and contacting the top surface of the sill cap (2Nb).

O. **Install the handle and lock hardware.** Refer to the manufacturer's instructions included with the hardware.

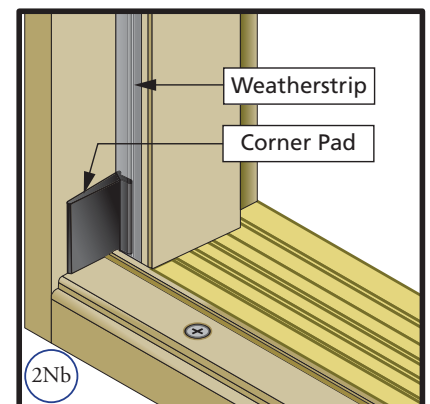
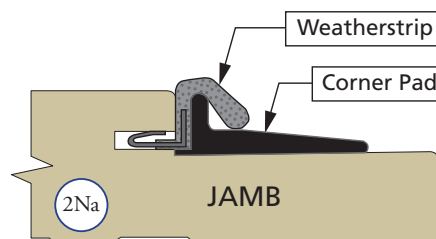
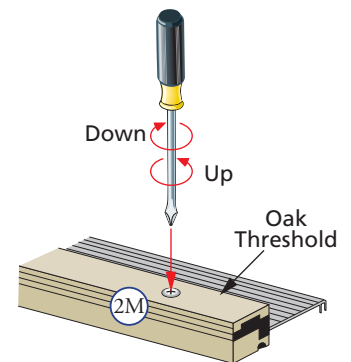
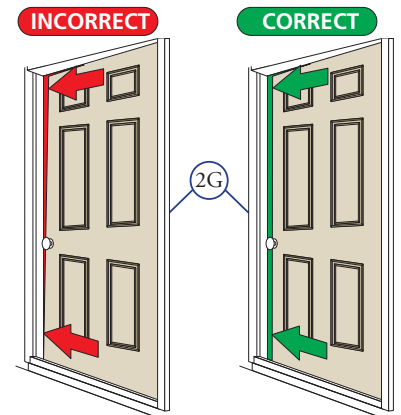
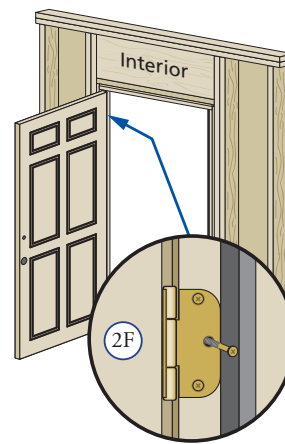

3 INTEGRATING THE DOOR TO THE WATER RESISTIVE BARRIER

- A. Place a corner bead of sealant between the brickmould and the exterior wall.
- B. Place a corner bead of sealant between the brickmould and the exterior door frame.
- C. Install aluminum flashing over the top of the head brickmould. Seal both ends of the flashing to the top brickmould and the wall.
- D. Install top flashing tape. Cut one piece of flashing tape 2" wider than the width of the top brickmould. Apply the top flashing tape so that it extends 1" beyond the end of the top brickmould. Position the tape so that it covers the vertical leg of the aluminum flashing and laps onto the sheathing above the door.
- E. Fold down the top flap of the water resistive barrier. Cut the barrier so it covers the vertical leg of the aluminum flashing, however does not lap onto the horizontal leg of the flashing.
- F. Apply flashing tape to the diagonal cuts. Cut pieces of flashing tape at least 1" longer than the diagonal cut in the water resistive barrier. Apply the tape covering the entire diagonal cut at both upper corners of the door. Press the tape down firmly.

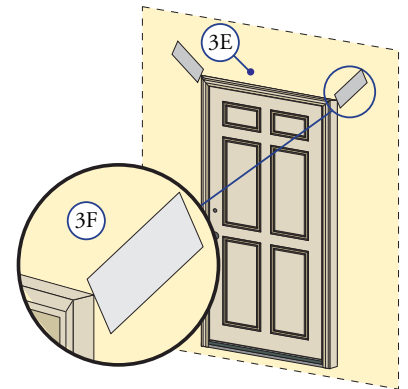
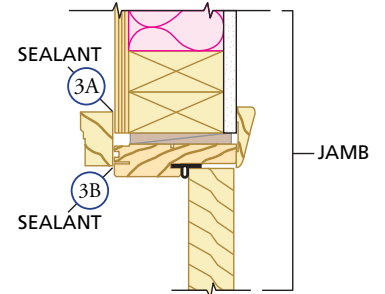
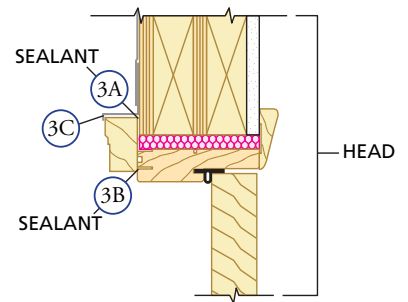

4 INTERIOR SEAL

Caution: Ensure use of low pressure polyurethane window and door installation foams and strictly follow the foam manufacturer's recommendations for application. Use of high pressure foams or improper application of the foam may cause the door to bow and hinder operation.

- A. Apply insulating foam. From the interior, insert the nozzle of the applicator approximately 1" deep into the space between the door and the rough opening and apply a 1" deep bead of foam. This will allow room for expansion of the foam and will minimize squeeze out. If using insulating foam other than Great Stuff™ Window and Door Insulation Foam by the Dow Chemical Company, allow the foam to cure completely (usually 8 to 24 hours) before proceeding to the next step.

Note: DO NOT completely fill the space from the back of the brickmould to the interior face of the opening.

Note: You may need to cut excess foam out of the lock strike.

- B. Check the door operation by opening and closing the door.

Note: If the door does not operate correctly, check to make sure it is still plumb, level, square and that the sides are not bowed. If adjustments are required, remove the foam with a serrated knife. Adjust the shims and reapply the insulating foam sealant.

- C. Apply interior trim as desired.

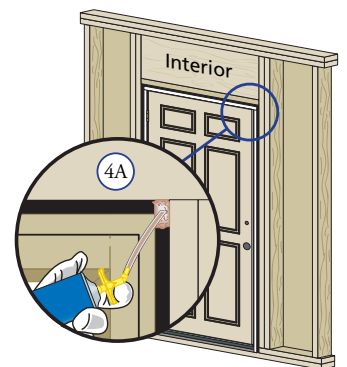

5 SEALING THE DOOR TO THE EXTERIOR WALL CLADDING

Note: When applying siding, brick veneer or other exterior finish materials, leave adequate space between the door frame and the material for sealant. Refer to the illustration that corresponds to your finish material. Not allowing adequate space and not using backer rod may cause the sealant to break down prematurely and allow water to infiltrate.

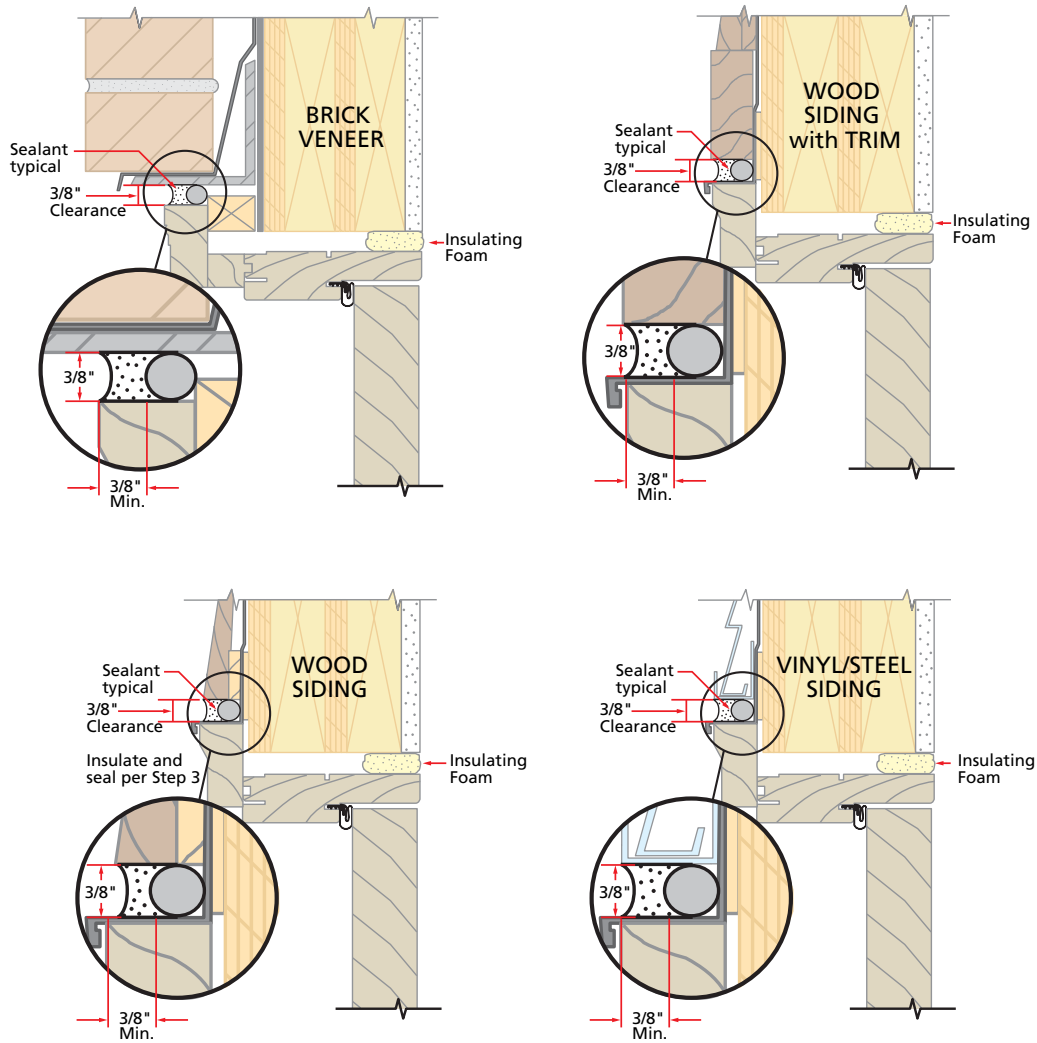

A. **Insert backer rod into the space around the door** as deep as it will go. This should provide at least a 3/8" clearance between the backer rod and the brickmould (5A).

Note: Backer rod adds shape and depth for the sealant line.

B. **Apply a bead of high quality exterior grade sealant to the entire perimeter of the door.** At each end of the bottom of the door, insert sealant into the spaces between the bottom of the door and the sill and connect it to the perimeter sealant.

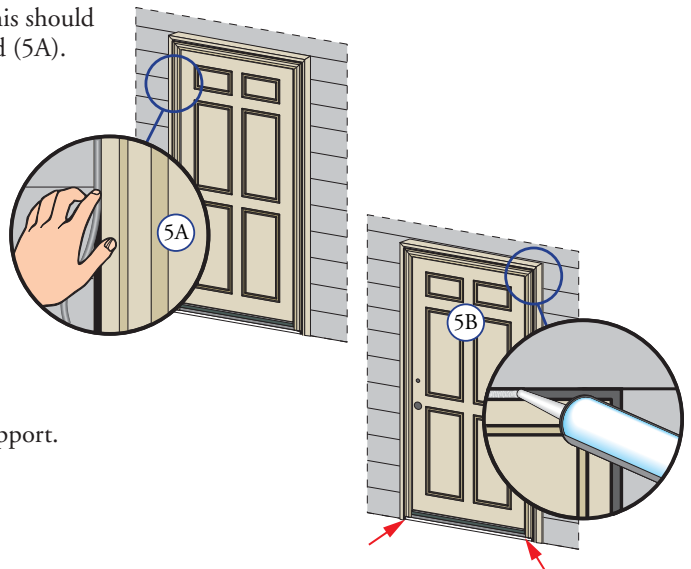

C. **Apply a bead of sealant** between the exterior edge of the sill and the sill support.

D. **Shape, tool and clean excess sealant.**

Note: This method creates a more flexible sealant line capable of expanding and contracting.

FINISHING INSTRUCTIONS

Note: DO NOT paint, stain or finish weatherstrip or vinyl parts! If paint, stain or finish gets on the mohair weatherstripping, wipe it off immediately with a damp cloth. To maintain proper product performance, do not remove weatherstrips or foam corner seal wedges. Air and water leakage may result if these factory-installed items are removed. After finishing, allow doors to dry completely before closing them. Pella will not be responsible for finishing imperfections. The use of unapproved finishes, solvents or cleaning chemicals may cause adverse reactions with door materials. Pella will not be responsible for problems caused by the use of unapproved materials. If in doubt, contact your local retailer or representative.

Use of inappropriate finishes, solvents, brickwash or cleaning chemicals will cause adverse actions with door materials and voids the Limited Warranty.

Door must be finished prior to or immediately after installation to help prevent damage caused by the elements. All exposed surfaces, including the top, side edges and cutouts for hardware must be finished and sealed equally to ensure lasting performance.

Apply stain (if desired) and three (3) coats of exterior grade clear coat of polyurethane or equivalent finish, with UV inhibitors. Sand before staining and between finish coats with a fine-grit sandpaper.

Exposure to the sun will break down the door's finish. Inspect the exterior finish at least once a year, evaluating the exterior finish by comparing it to the interior finish. If the exterior finish appears to have lost its gloss compared to the interior, apply a new top coat to the exterior of the door.

IMPORTANT NOTICE

Because all construction must anticipate some water infiltration, it is important that the wall system be designed and constructed to properly manage moisture. Pella Corporation is not responsible for claims or damages caused by anticipated and unanticipated water infiltration; deficiencies in building design, construction and maintenance; failure to install Pella products in accordance with Pella's installation instructions; or the use of Pella products in wall systems which do not allow for proper management of moisture within the wall systems. The determination of the suitability of all building components, including the use of Pella products, as well as the design and installation to allow for proper management of moisture within the wall systems. The determination of the suitability of all building components, including the use of Pella products, as well as the design and installation of flashing and sealing systems are the responsibility of the Buyer or User, the architect, contractor, installer, or other construction professional and are not the responsibility of Pella.

Pella products should not be used in barrier wall systems which do not allow for proper management of moisture within the wall systems, such as barrier Exterior Insulation and Finish Systems, (EIFS) (also known as synthetic stucco) or other non-water managed systems. Except in the states of California, New Mexico, Arizona, Nevada, Utah, and Colorado, **Pella makes no warranty of any kind on and assumes no responsibility for Pella windows and doors installed in barrier wall systems. In the states listed above, the installation of Pella Products in barrier wall or similar systems must be in accordance with Pella's installation instructions.**

Product modifications that are not approved by Pella Corporation will void the Limited Warranty.