



# PELLA® 250 SERIES PREMIUM FOLDING DOOR AND FOLDING WINDOW INSTALLATION INSTRUCTIONS

## Contents:

Warranty Information .....	02
Parts/Tools .....	03
Product Safety Information .....	04
Installation Information .....	05
Load Verification .....	06
Opening Preparation .....	07
Frame Assembly .....	08
Frame Installation .....	14
Hardware Preparation / Setup / Installation .....	19
Tall Door Information .....	26
Panel Installation .....	27
Folding Window .....	32
Low Profile Sill Installation .....	34
Flush Sill Installation .....	36
Astragal and Directional Carrier Assembly Installation .....	37
Handle Hardware Installation .....	38
Panel Adjustments .....	41
Strike Plate Installation .....	43
Strike Cap Installation .....	44
Magnet Installation .....	45
Hinge Shim Installation .....	47
Hardware Exploded View .....	48
Frame Assembly Exploded Views .....	49
1" Nail Fin Cross Section .....	53
1-3/8" Nail Fin Cross Section .....	54
Low Profile Sill Cross Sections .....	55
Interior and Exterior Seal .....	58
Sill Pan Instructions .....	59





## WARRANTY INFORMATION

---

These instructions were developed and tested for use with wall systems designed to manage water. These instructions are not to be used with any other construction methods or door frame types. Installation instructions for use with other construction methods or frame types may be obtained from Pella® Corporation, your local Pella retailer or [www.installpella.com](http://www.installpella.com). Building designs, construction methods, building materials, and site conditions unique to your project may require an installation method different from these instructions and/or additional care. Determining the appropriate installation method is the responsibility of you, your architect, or construction professional.



Always read the Limited Warranty before purchasing or installing Pella® products. By installing this product, you are acknowledging that this Limited Warranty is part of the terms of the sale. Failure to comply with all Pella installation and maintenance instructions may void your Pella product warranty. See written Limited Warranty for details, including exceptions and limitations at [pella.com/warranty](http://pella.com/warranty), or contact Pella Customer Service at 877-473-5527.

BY PURCHASING, INSTALLING OR USING PELLA PRODUCTS (INCLUDES PELLA GOODS AND PELLA SERVICES), YOU AGREED TO THE TERMS OF THE LIMITED WARRANTY AND YOU AND PELLA FURTHER AGREE TO ARBITRATE DISPUTES ARISING OUT OF OR RELATING TO PELLA PRODUCTS, AND YOU WAIVE ANY RIGHT TO PARTICIPATE IN A CLASS ACTION RELATED TO PELLA PRODUCTS unless you notify Pella of your decision to opt out of the Arbitration Agreement no later than ninety (90) calendar days from the date you purchased or otherwise took ownership of Your Pella Goods. Opting out of the Arbitration Agreement will not affect the coverage provided by any applicable limited warranty pertaining to Your Pella Products. For opt out information and additional details please read the Limited Warranty and Arbitration Agreement for your Pella Products at [www.Pella.com/arbitration](http://www.Pella.com/arbitration).



## BEFORE BEGINNING FRAME ASSEMBLY AND INSTALLATION:

### Read through and understand all the assembly steps and the installation process.

Carefully remove shipping/packaging materials and check for any product damage.

Confirm the correct product was received. (Size, color, handing, etc..)

Confirm all parts as listed in the QC Checklist are present and accounted for.

If there is any parts missing, product damage, wrong parts, or other issues...



**DO NOT assemble! Contact Pella Customer Service at: 877-473-5527.**

**Or Contact your local sales representative or customer service team.**

Before purchasing and installing, verify performance of product meets the requirements of the application and region. Not all products or sill types are rated for water performance. To reduce the likelihood of water infiltration where application exceeds product performance, install doors under an overhang that extends to meet a 45-degree line from the door sill and slope the exterior 2 degrees away from the door or use a stepdown.

**FAILURE TO DO SO MAY RESULT IN DAMAGE TO THE INTERIOR OF THE STRUCTURE.**

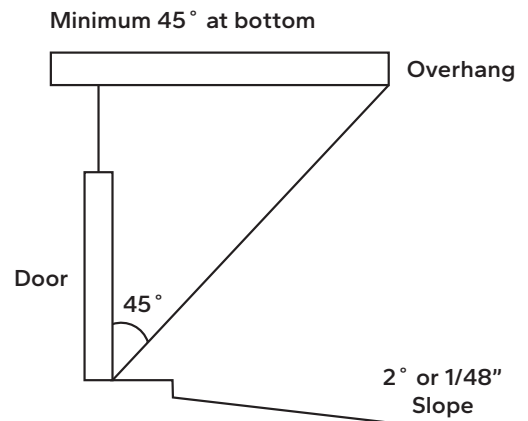

### Tools Needed:

- #2 Phillips handheld screwdriver
- Pry bar
- Level
- Square
- Safety glasses
- Utility knife
- Hammer
- Wood block
- Mallet
- Tape measure
- Drill with 3/8", 9/64", and 3/4" bits
- Fine tooth chop saw
- Sealant gun with polyurethane sealant
- Speed square

### Supply List:

- Moisture resistant shims/spacers (12 to 20)
- 2" galvanized roofing nails (1/4 lb.);  
Or #8 x 2" screws to fasten nail fin
- Masonry screws for concrete applications  
(minimum of 3/16" diameter x 3")
- Closed cell foam backer rod/sealant backer (21 to 30 ft.)
- Pella® SmartFlash™ foil backed butyl window and door flashing tape or equivalent
- Pella Window and Door Installation Sealant or equivalent high quality, multi-purpose sealant
- Low expansion, low pressure polyurethane insulating window and door foam sealant. DO NOT use high pressure or latex foams
- Sill pan 6-5/8" x (Rough Opening Width +2)
- Pella aluminum sill support or wood blocking
- Interior trim and/or jamb extensions (15 to 40 ft.)



# IMPORTANT SAFETY AND PRODUCT INFORMATION

**Safety Alert Symbol Reference:** These symbols are intended to alert you to potential injury hazards and information. Obey all safety messages.

<b>COULD</b> Result in:	 <b>WARNING</b> Major Injury/Death	<b>COULD</b> Result in:	 <b>CAUTION</b> Minor Injury	<b>COULD</b> Result in:	 <b>NOTICE</b> Product or Property Damage	<b>COULD</b> Result in:	 <b>IMPORTANT</b> Procedure and Product Info.
----------------------------	--	----------------------------	------------------------------------	----------------------------	---	----------------------------	---

**WARNING** To ensure safety and security and help prevent property damage, including possible damage to your window or door, close and lock windows and doors any time they are not being used for venting on a nice day, and particularly during high winds or rain. Ensure all windows and doors are properly fastened to the wall structure according to the product anchor instructions. It is the responsibility of the Buyer or User, the architect, contractor, installer, or other construction professional to ensure the appropriate windows and doors are chosen for the project and the wall construction is designed to resist all loads in accordance with local building code requirements.

**CAUTION** Many doors in older homes are painted with lead-based paint. Removal of old doors may disturb this paint. Proper precautions must be taken to minimize exposure to dust and debris. Consult state or local authorities and/or go to [www.epa.gov/lead](http://www.epa.gov/lead) for more information.

**NOTICE** Pella products must be stored in an upright, level position not exposed to weather. The storage must be ventilated and provide protection from direct sunlight and excessive temperature.

**IMPORTANT NOTICE** Because all construction must anticipate some water infiltration, it is important that the wall system be designed and constructed to properly manage moisture. Pella Corporation is not responsible for claims or damages caused by anticipated and unanticipated water infiltration; deficiencies in building design, construction and maintenance; failure to install Pella products in accordance with Pella's installation instructions; or the use of Pella products in wall systems which do not allow for proper management of moisture within the wall systems. The determination of the suitability of all building components, including the use of Pella products, as well as the design and installation of flashing and sealing systems are the responsibility of the Buyer or User, the architect, contractor, installer, or other construction professional and are not the responsibility of Pella.

Pella products should not be used in barrier wall systems which do not allow for proper management of moisture within the wall systems, such as barrier Exterior Insulation and Finish Systems (EIFS) (also known as synthetic stucco) or other non-water managed systems. Except in the states of California, New Mexico, Arizona, Nevada, Utah and Colorado, Pella makes no warranty of any kind on and assumes no responsibility for Pella windows and doors installed in barrier wall systems. In the states listed above, the installation of Pella Products in barrier wall or similar systems must be in accordance with Pella's installation instructions. Product modifications that are not approved by Pella Corporation will void the warranty.

**CARE AND MAINTENANCE:** Refer to the Pella Owner's Manual. Visit [www.pella.com](http://www.pella.com) or your local retailer for more information.

**CLEANING INSTRUCTIONS:** Refer to the Pella Owner's Manual for comprehensive maintenance and cleaning information. Visit [www.pella.com](http://www.pella.com) or your local retailer for more information.

**GLASS:** Remove any protective film and labels and clean the glass, using a soft, clean, grit-free cloth and mild soap or detergent. Be sure to remove all liquid by wiping dry or use a clean squeegee.

**NOTICE** DO NOT apply any other types of film to the glass. Doing so could void product warranty.

**PELLA® 250 SERIES DOOR FRAMES:** The vinyl frame may be cleaned using the same method as the glass. For stubborn dirt, a "non-abrasive" cleaner such as Bon-Ami® or Soft Scrub® may be used.

**NOTICE** Do not use solvents such as mineral spirits, toluene, xylene, naphtha or muriatic acid as they can dull the finish, soften the vinyl and/or cause failure of the insulated unit seal.

**NOTICE** Do not use Isopropyl Alcohol on laminated surfaces as it will damage the finish. Keep door tracks clear of dirt and debris. Keep weep holes open and clear of obstructions.

**NOTICE** DO NOT use abrasives. DO NOT scrape or use tools that might damage the surface.

**NOTICE** DO NOT use inappropriate solvents or brickwash or cleaning chemicals. If you do, permanent damage can result and the product failure, loss or damage would not be covered by the Limited Warranty.





# INSTALLATION INSTRUCTIONS FOR TYPICAL WOOD FRAME CONSTRUCTION

These instructions were developed and tested for use with typical wood frame wall construction in a wall system designed to manage water. These instructions are not to be used with any other construction method.

Building designs, construction methods, building materials, and site conditions unique to your project may require an installation method different from these instructions and additional care. Determining the appropriate installation method is the responsibility of you, your architect, or construction professional.

**NOTICE** With multiple tracks it's very important to make sure the threshold is level the entire length of the opening and the distance from the interior to exterior.

**NOTICE** FAILURE TO PROVIDE ADEQUATE ROUGH OPENING SILL PROTECTION FOR WOOD THRESHOLDS WILL VOID PRODUCT WARRANTY.

**NOTICE** Proper steps must be taken when flashing and applying sealant to ensure proper waterproofing of the unit.

## SUGGESTED METHOD OF INSTALLATION

Due to the complexity of the Folding Door System and the lengthy install manual it is highly suggested the install is done step by step with the manual.

It is recommended to read each section individually followed by the hands on install of that particular section. It is very important to thoroughly understand and follow each section of instructions as written. Failure to do so could result in faulty install.

Due to the thickness (taller profile) of the threshold it is suggested to cut the foundation/subfloor of the opening 1-1/2" lower so there is not such a big step over at the sill.

Refer to page 34 for Low profile sill example details and 38 for flush sill example details, if applicable.

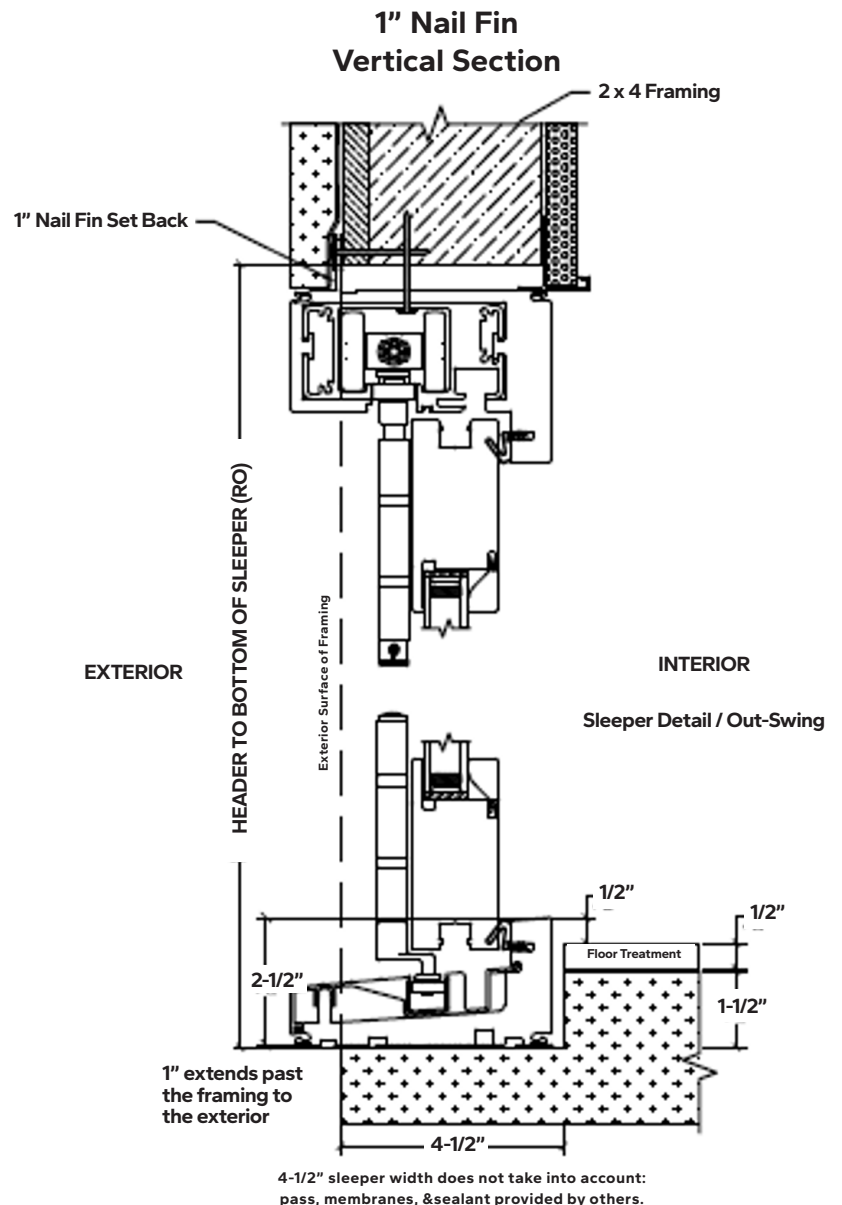



# HEADER AND LOAD VERIFICATION

## CAUTION

Fully inspect the opening before you begin. Verify if the header is a solid beam or if there is any material furring down the opening. If there is lumber furring down the opening, make sure it is strapped down with something like ST22 type straps. Due to these doors being hung from the header of the frame, a furring strip just nailed will not hold the weight of the door and in time the furring strips will start to pull away and sag causing the door to be out of alignment and possibly drag across the threshold damaging it. These straps should go from the top of the header down the exterior face, under the header and furring material, then back up the opposite side and up the interior face to the top. Depending on the size of the door, position these straps in more than one location from the center working out towards the jambs.

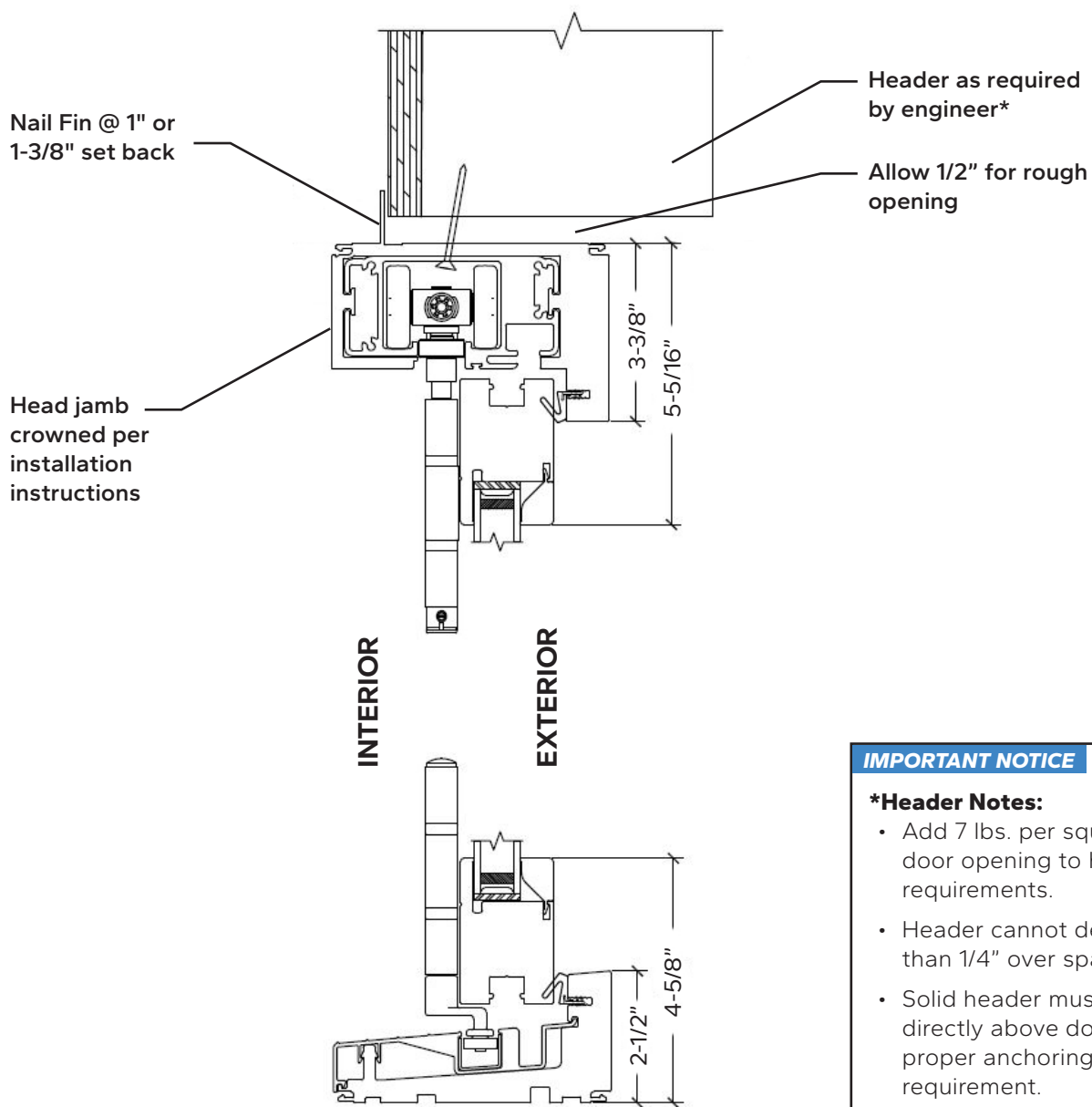

## IMPORTANT NOTICE

### \*Header Notes:

- Add 7 lbs. per square foot of door opening to header load requirements.
- Header cannot deflect more than 1/4\" over span.
- Solid header must be directly above door for proper anchoring and load requirement.

# 1 Opening Preparation:

A. Confirm the opening is plumb and level.

**NOTICE** It is critical the bottom is level and does not slope to the interior or exterior.

B. Remove dirt, oil or debris from the opening and surrounding wall surfaces.

C. **Confirm the door will fit the opening.** Measure all four sides of the opening to make sure it is 1/2" to 3/4" larger than the door in both width and 1/2" larger in height. Measure the width and height in several places to ensure the header or studs are not bowed.

**NOTICE** 1-1/2" or more of solid wood blocking is required around the perimeter of the opening. Fix any problems with the rough opening before proceeding.

**NOTICE** It is important to consider the door's exposure to weather, the exterior landing surface type and its proximity to the door sill, and to confirm impervious exterior surfaces properly slope away from the door prior to continuing with installation.

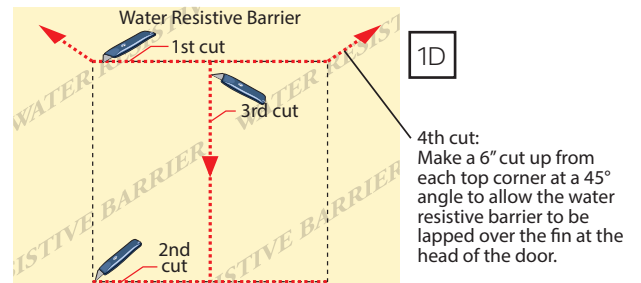

D. Cut the building wrap.

E. **Fold the building wrap in at the jambs and staple it in place.**  
Fold the top flap up and temporarily fasten with flashing tape.

**NOTICE** If using a sill pan or if the door will be installed on a concrete slab, refer to the instruction page at the end of this instruction.

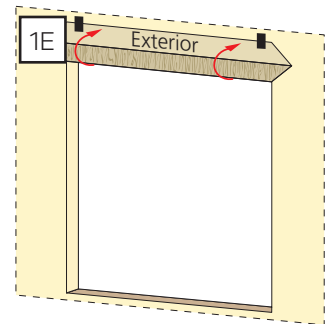

F. Cut two pieces of flashing tape 12" longer than opening width.

G. **Apply sill flashing tape #1** at the sill extending 1" to the exterior and 6" up each jamb.

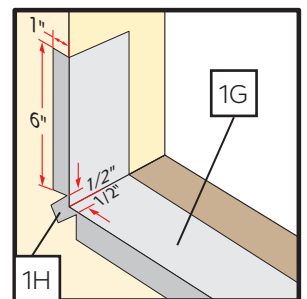

H. **Cut 1" wide tabs** at each corner by tearing the foil 1/2" each way from the corner.

I. **Apply sill flashing tape #2** overlapping tape #1 by at least 1" by 1" minimum.

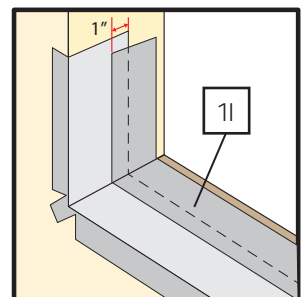

# 1 Opening Preparation (continued):

- J. Place three 3/8" beads of sealant across the opening sill. Place the interior-most bead 1/2" from where the interior of the door sill will remain after installation. Continue this bead up the sill pan lip, if applicable.
- K. Place a second bead beginning from the interior bead 1/2" from each side, out to the exterior of the framing and along the opening. Leave 2" voids 4" from the corner and at center. Place a third bead where the exterior of the door sill will remain after installation.

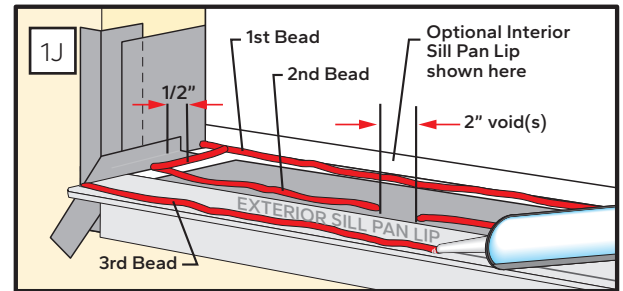
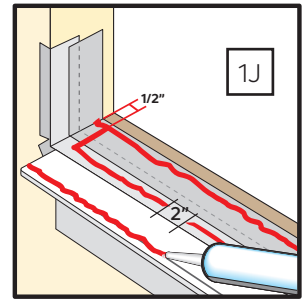

# 2 Frame Assembly:

- A. Identify frame parts necessary (head, 2 jambs and a sill). The sill can be identified by the weep holes.

Position the head, sill and 2 side jambs exterior side up on a clean flat surface in the orientation in which they will be assembled. Insert wood blocks under each corner to support and level the corners on an uneven surface. Or position the frame parts on sawhorses.

Be sure to assemble one frame corner at a time. Joining the sill to the jambs first, followed by joining the head to the jambs.

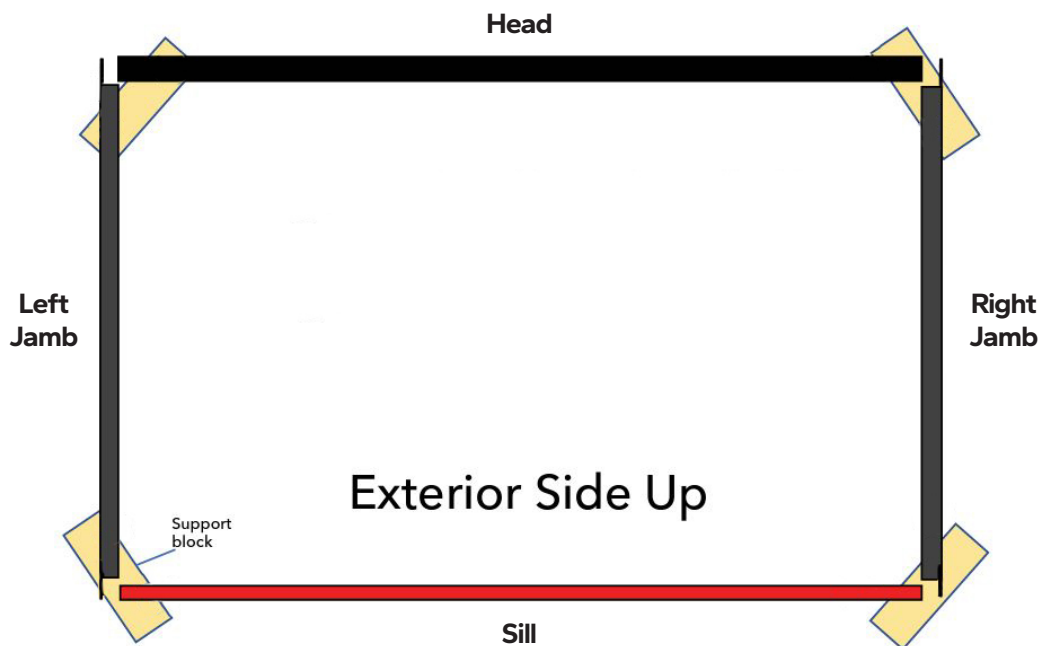

# 2 Frame Assembly:

**NOTICE** Use care if using an impact driver during the Frame Assembly Process. If not careful, impact drivers can cause screw head breakage.

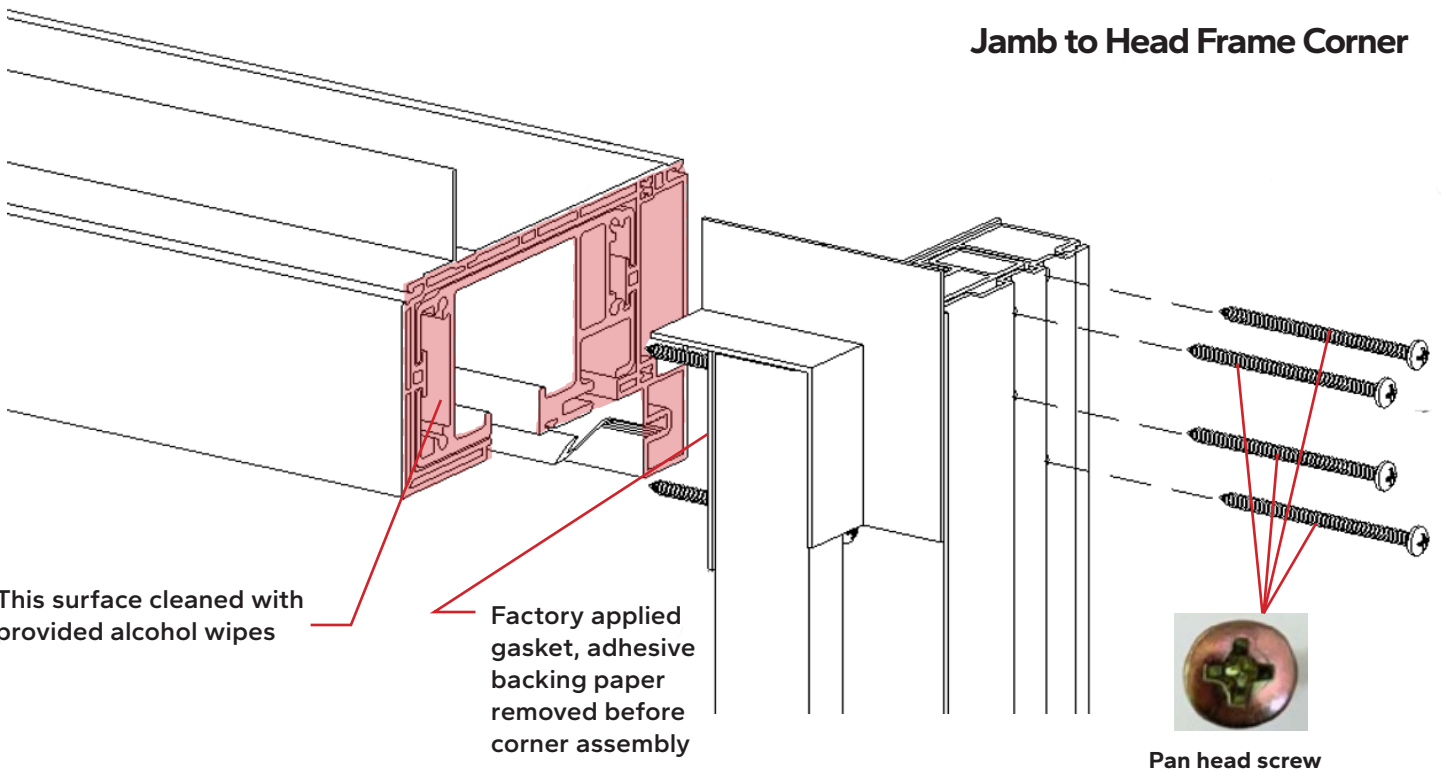
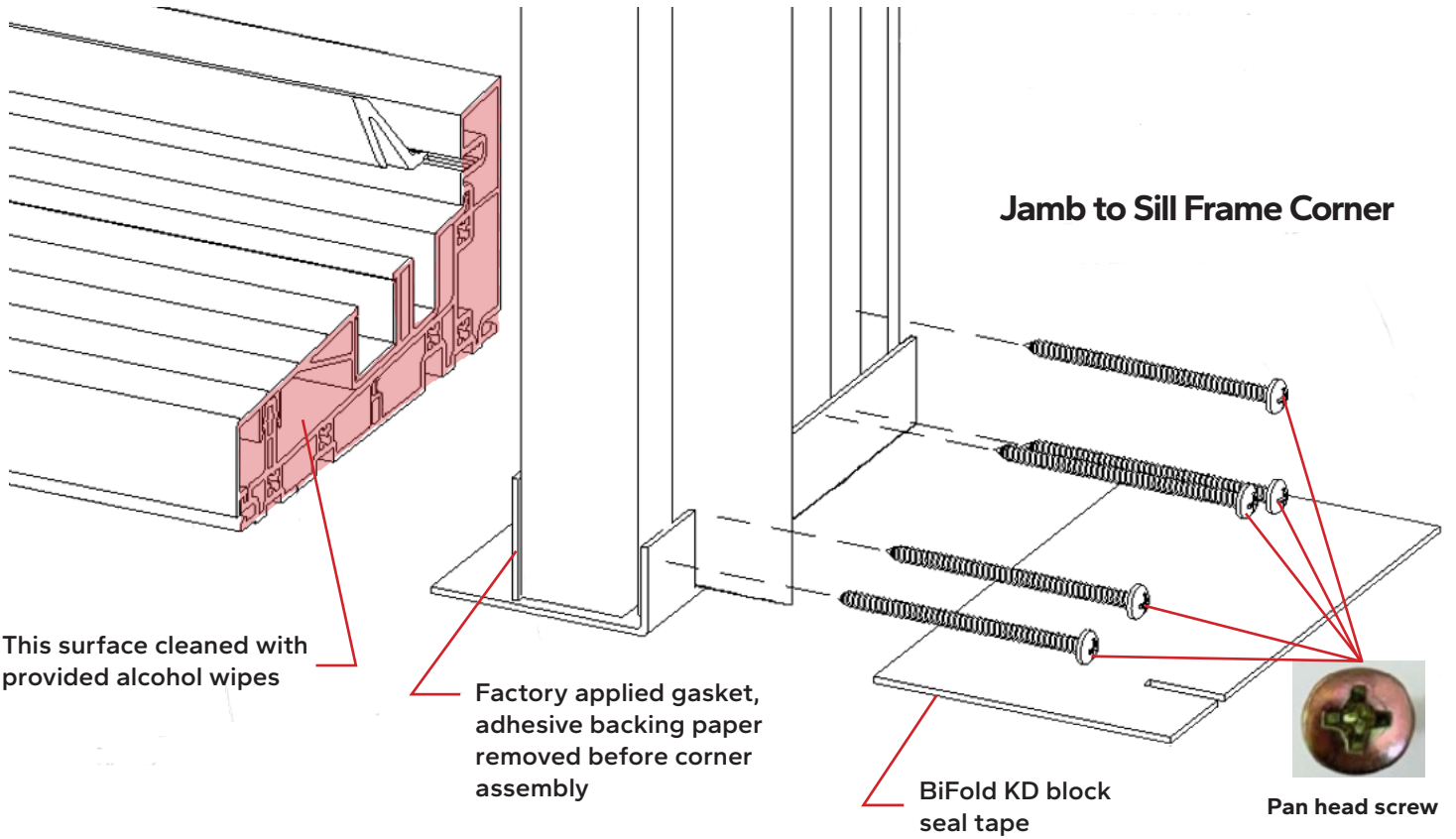



## 2 Frame Assembly (continued):

- B. Using the provided alcohol wipes, clean the area where the jamb gaskets will be adhering to on the head and sill.



- C. Remove the adhesive backing paper from the gasket on one jamb frame corner near the sill. Position the jamb and sill together.



- D. Push the packaged pan head frame assembly screws through the gasket on one jamb frame corner. Start each screw aligning it with and into the correct screw boss.

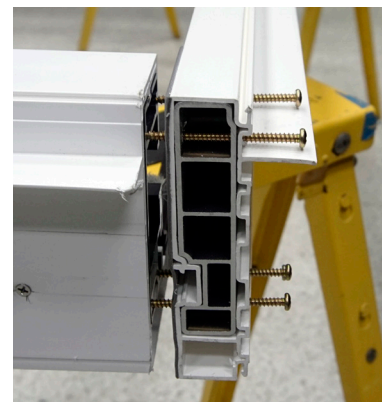
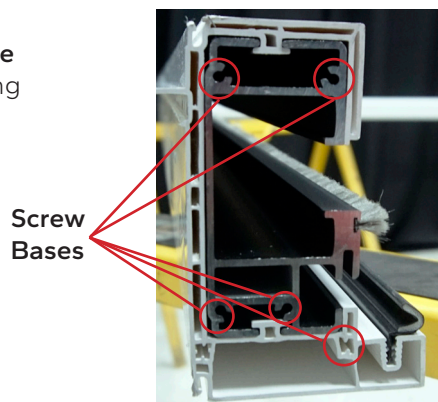

- E. One corner at a time, make sure each screw is aligned with the proper screw boss, and tighten each screw sequentially and evenly until the jamb is tightened firmly against the sill and/or head. Be careful not to over torque and strip out the vinyl or pull through the jamb's walls.

**NOTICE** Use care if using an impact driver during the Frame Assembly Process. Impact drivers can cause screw head breakage.

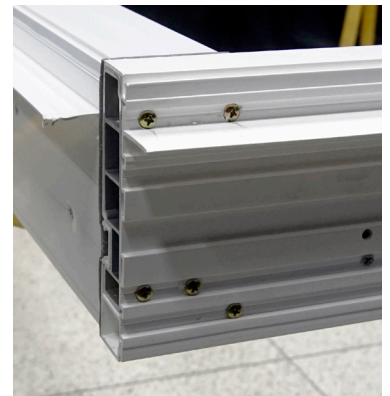
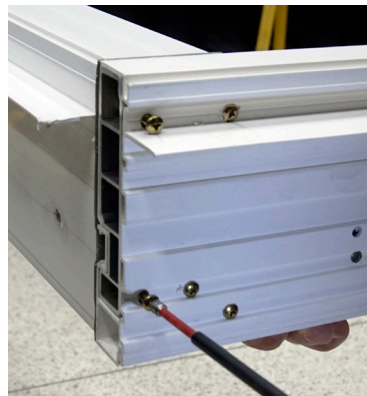

Repeat 2B-2E on the other frame corners.

## 2 Frame Assembly (continued):

- F. Remove the adhesive backing paper of the seal tape to expose the sticky side of the tape.

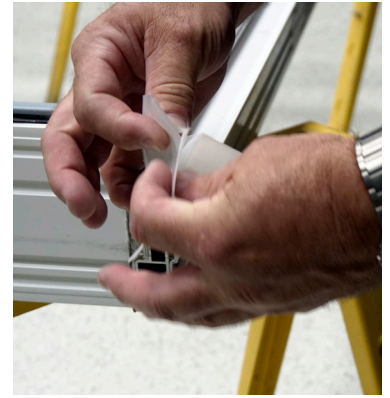

- G. Apply the provided seal tape to the outside of the jamb-sill joint on both sides. Press the tape firmly in place.



- H. Once the tape has been applied, remove the Mylar backing. Once the Mylar backing has been removed, work the tape into any voids in the frame to ensure a good seal.



- I. Apply the nail fin corner. Using the provided sealant, fill the outer most hole on top of the frame as well as apply a bead of provided sealant to the nail fin on the jamb and head. Firmly apply the nail fin corner into place. Make sure the nail fin corner is on the outer portion of the frame mounted to the face of the frame.

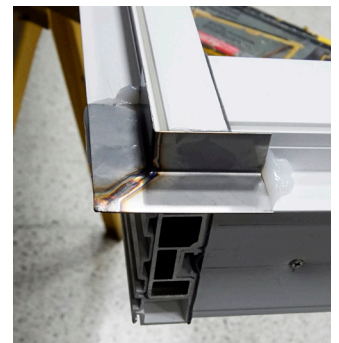



## 2 Frame Assembly (continued):

- J. **Apply provided sealant to the sill to jamb corners.** Make sure the twin bolt channel and guide roller channel both are sealed with the sealant.

Tool the sealant to make sure the corner is covered.

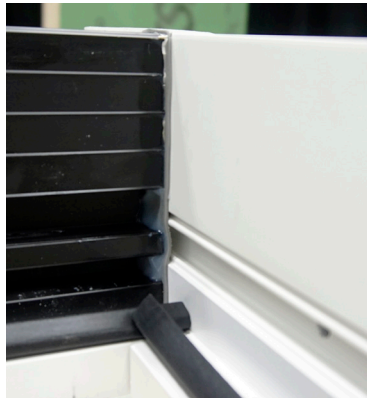
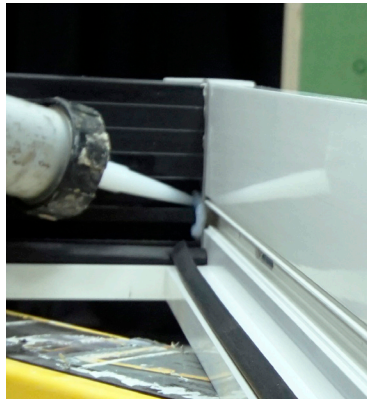

Channels with sealant



## 2 Frame Assembly (continued):

On low profile thresholds there is no jamb gasket for the sill to adhere to. The SM5555 caulking, that is supplied, must be used on the jamb to create a gasket for the sill to adhere to. Add a liberal amount to ensure the sill will be in complete contact with the caulking and install the sill. There will only be two screws that will align with the sill. It will only attach one way where both screw bosses will be aligned.

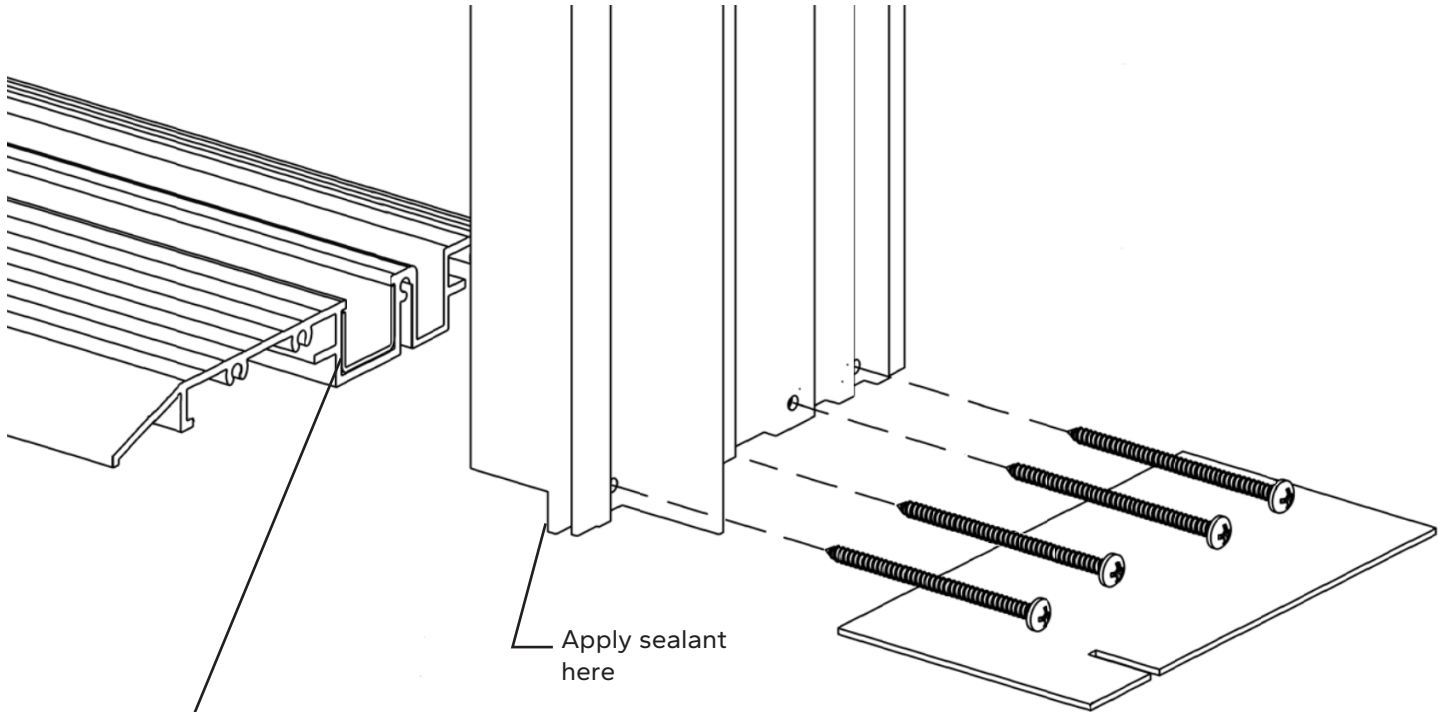

**NOTICE** BEFORE INSTALLING THE FRAME MAKE SURE TO FILL THE CHANNELS AT THE JAMB CORNERS WHERE THE ROLLER RIDES IN. THESE CHANNELS WILL SIT LOWER THAN THE JAMBS LEG AND NEEDS TO BE FILLED AT THE JOINT.

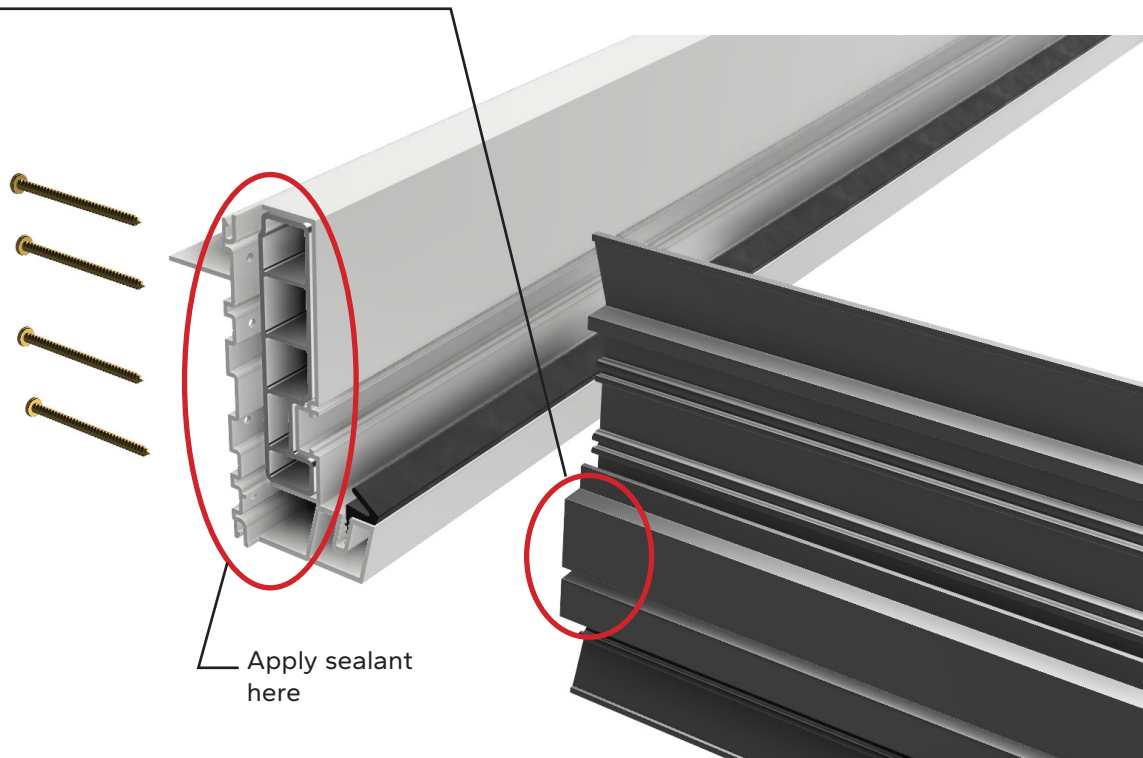

# 3 Frame Installation:

A. Confirm the sill is level, free of any crowns and sags.

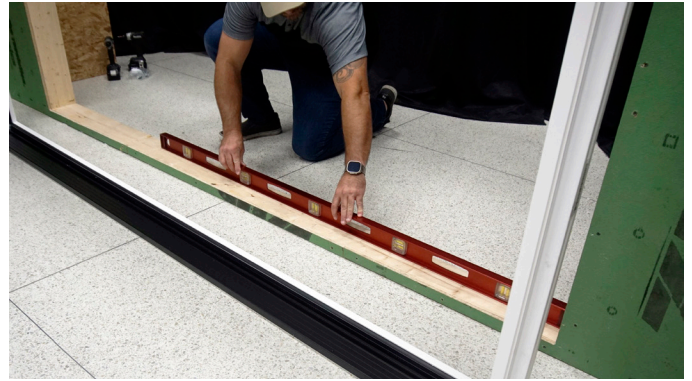
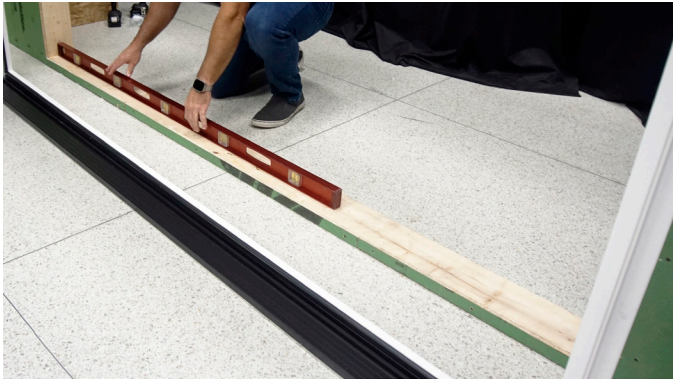

B. Center the bottom of the door in the opening and tilt the door into position. Do not slide the door into the opening. Sliding will damage the sealant lines. Check the jambs for plumb and confirm there is room for shimming between the jambs and opening on each side.

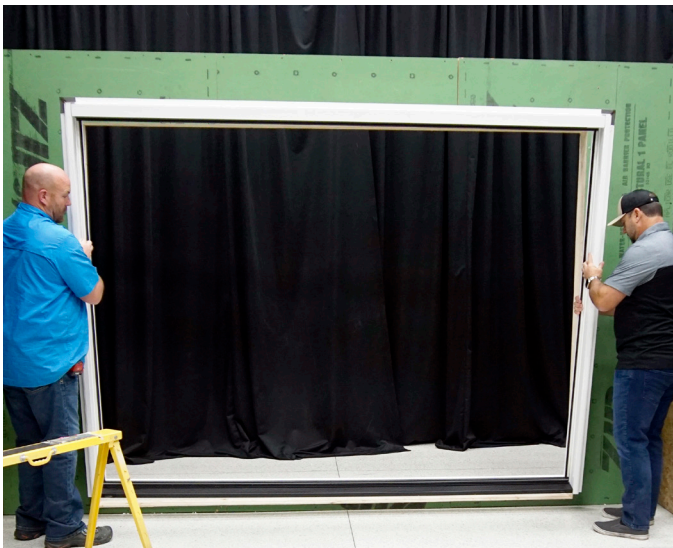

C. While a helper holds the door in place, walk across the sill to compress the sealant and confirm the frame is firmly on the threshold, free of any humps due to the sealant under it.

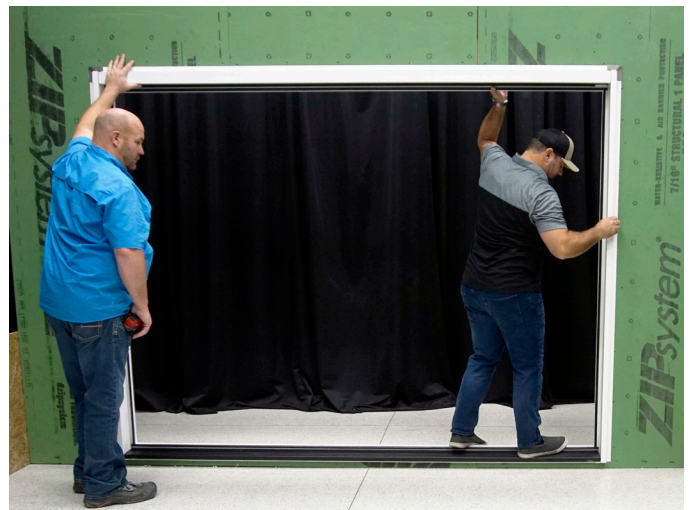



# 3 Frame Installation (continued):

Doors with a Nail Fin (For Doors without a nail fin, proceed to step 3H.):

- D. Place shims between the frame and rough opening at the sill to wedge the bottom of the frame in place. Insert a screw through the exterior nail fin near the sill on each side of the frame.

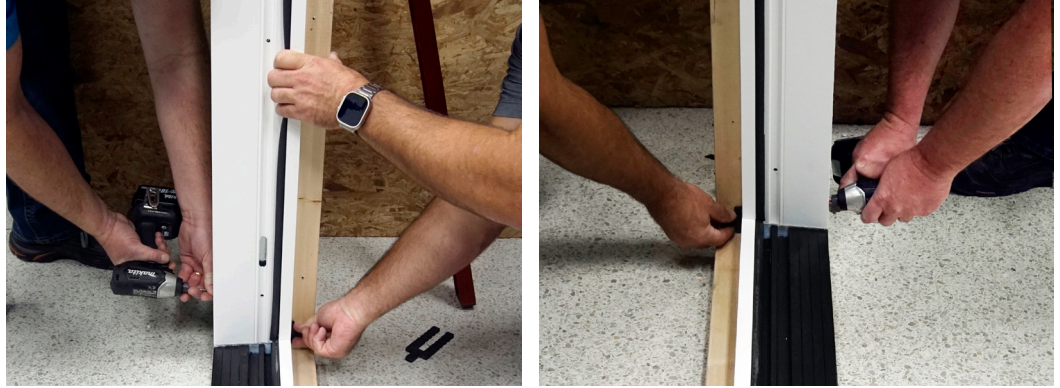

- E. At one jamb, place shims between the frame and rough opening at the head to wedge the top of the frame in place. Insert a screw through the exterior nail fin near the head on the side of the frame.



- F. Before inserting a screw in the nail fin at the head on the other jamb, measure the frame diagonally to confirm it is square.

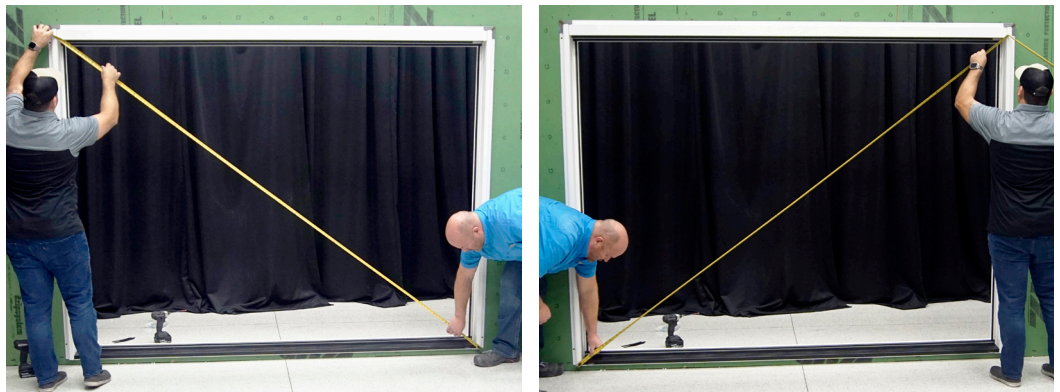

- G. Insert shims between the frame and rough opening at the head on the other side of the frame to wedge the top of the frame in place. Insert a screw through the exterior nail fin near the head on the side of the frame.



# 3 Frame Installation (continued):

H. With the frame screws provided, and shims behind each screw using the pre-drilled frame screw installation holes, secure the four corners. Measure the frame diagonally to confirm it is square.

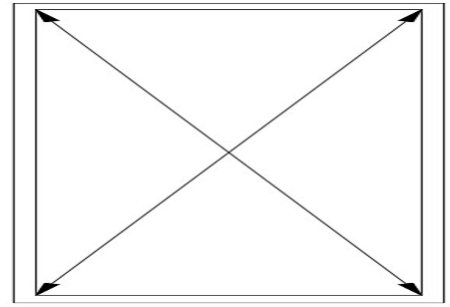
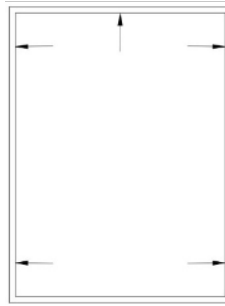

## Doors With or Without a Nail Fin:

I. Insert one screw near the center of the head to keep the head from sagging.



J. From the interior, pick one side of the frame and measure the daylight opening height near the jamb. Then measure the daylight opening height at the center.

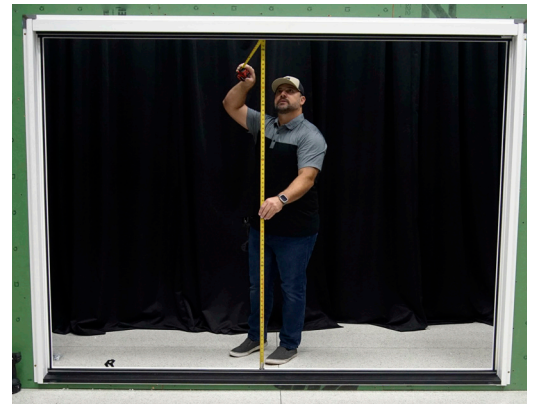

K. Use the center screw from Step 3I to lift the head of the door frame to get the correct crown for the specific width door.

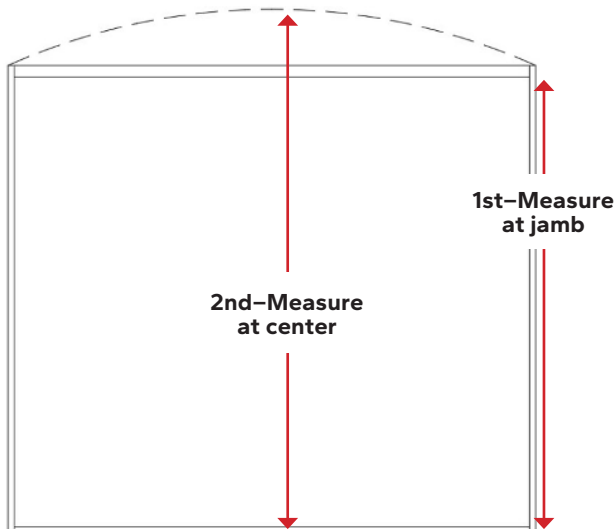

### CROWNING GUIDELINES:

There are 3 different measurements for crowning folding doors depending on the size of door being installed.

Crowning the frame head of the folding door is a very important step, not done or done incorrectly can cause damage to the door and faulty operation.

- 8-10 foot door-----1/16 inch crown
- 10-12 foot door-----1/8 inch crown
- 12 foot and larger-----3/16 inch crown



### 3 Frame Installation (continued):

- L. Once the crown is set at the appropriate height, finish securing the frame.

**Secure the jambs** of the frame placing the screws in all the pre-drilled frame holes. Every hole must be used.

**Place shims at every screw location** to eliminate any frame movement (shim at least every 16" on the jambs). Use a level to make sure the jamb is plumb side to side and there is no daylight between the level and the frame. Level and secure the jambs making sure they are perfectly straight.

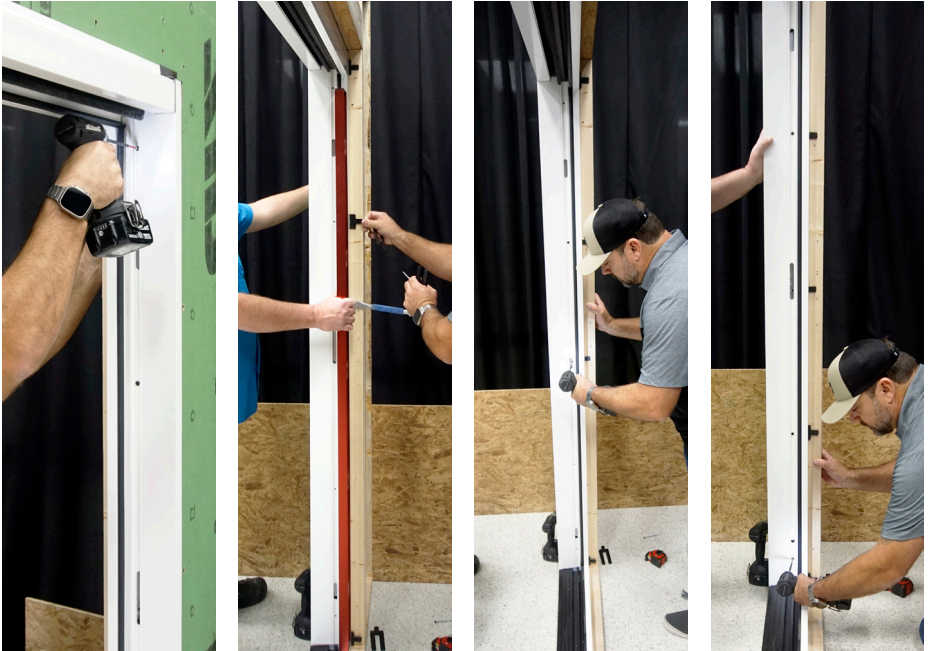

- M. Secure the head of the door frame placing the screws in all the pre-drilled frame holes. On each end of the head is a grouping of three screws, every hole must be used.

**Place shims at every screw location** to eliminate any frame movement (shim every 16" on the frame head). Use a level to make sure there is no daylight between the level and the frame.



- N. Install the euro cap on the pivot side of the frame. Pinch the top of the legs to make the install of the cap easier.

**Do not install the strike side cap at this time.**

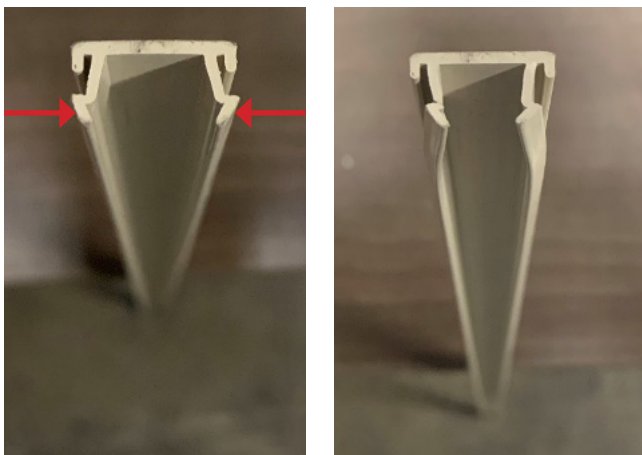

### 3 Frame Installation (continued):

- O. Complete the frame install by inserting screws through the nail fin spaced approximately every 12".

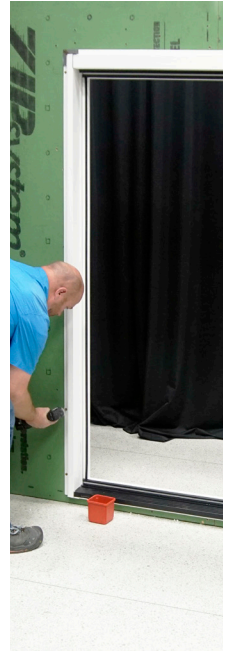
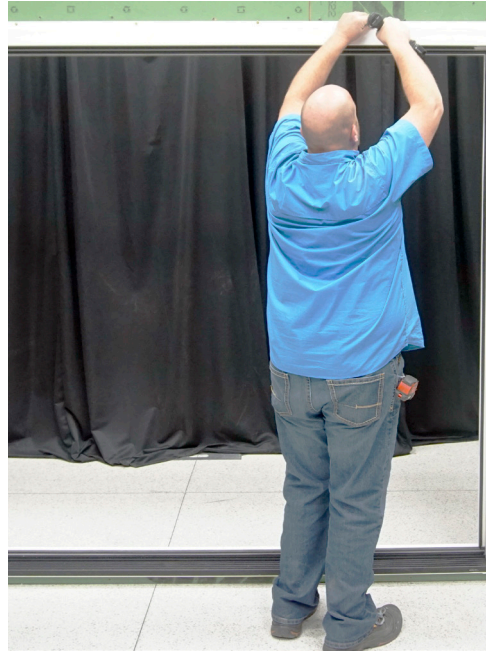

- P. Use a clean cloth to clean out both sides of the head track where the panel carrier set hardware will be installed.





# 4 Hardware Preparation/Set-Up/Installation:

**NOTICE** In the hardware box will be a hardware placement sheet. This diagram will show everything from panel placement to hardware placement. This sheet is key, follow the panel and hardware placement shown on the one supplied with the order. Every sheet is specific to the door ordered.



**Study the hardware placement sheet.** This sheet is key to a successful installation! It shows correct hardware placement and installation as well as panel placement order.

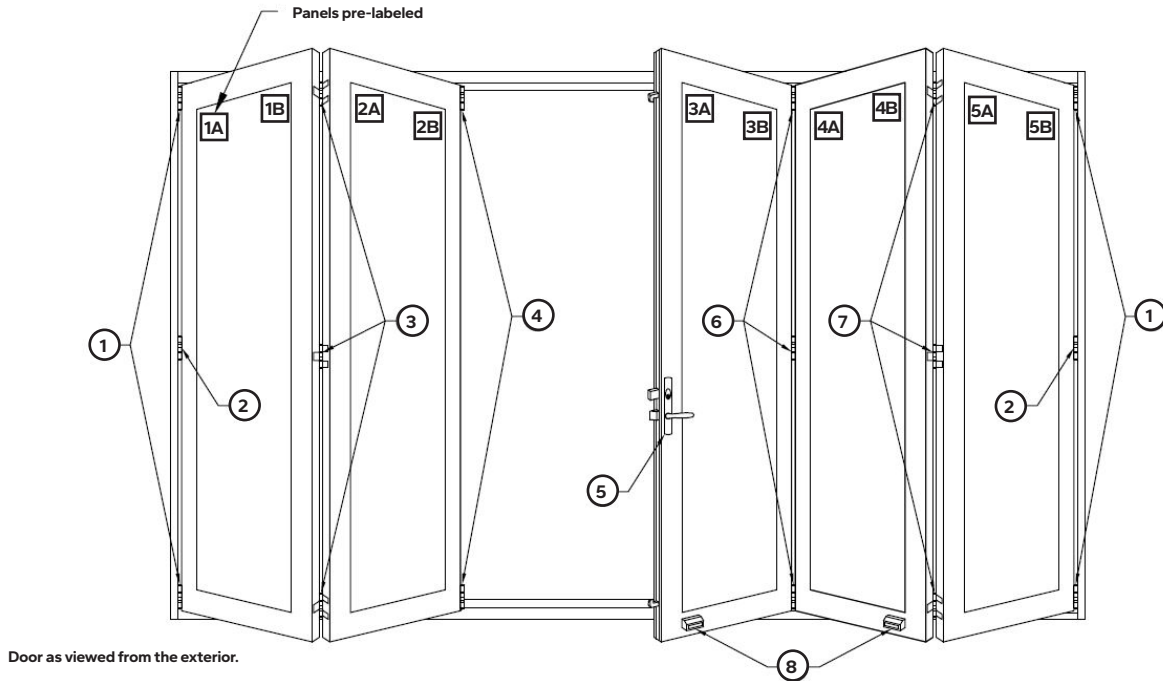

Door as viewed from the exterior.

Folding Door Parts						
	Qty.	Description		Qty.	Description	
	1	2	E3 CPS Pivot Set	7	1	E3 HHSS Offset Hinge Set with Handle
	2	2	E3 WPS Middle Wall Pivot (used with doors over 90')	8	1	Center Magnets
	3	1	E3 HSS Flat Hinge Set with Handle			
	4	1	E3 CRCS Right Carrier Set			
	5	1	Hardware Set			
	6	1	CICS Intermediate Corner Set			

**NOTICE** Before hanging the hardware there are a few steps that **MUST** be done for the door to work properly and with proper clearance.

**NOTICE** **TO AVOID HARDWARE MIX-UP, DO NOT OPEN ALL THE HINGE HARDWARE AT THE SAME TIME!** Open each hardware box only as needed.

# 4 Hardware Preparation/Set-Up/Installation (continued):

- A. **Using the hardware placement sheet provided** in the hardware box, identify the carrier set as previously done on the pivot block. Do the same to all the carrier sets of hardware for the door. This will allow for more adjustment after the hardware is installed in the track.

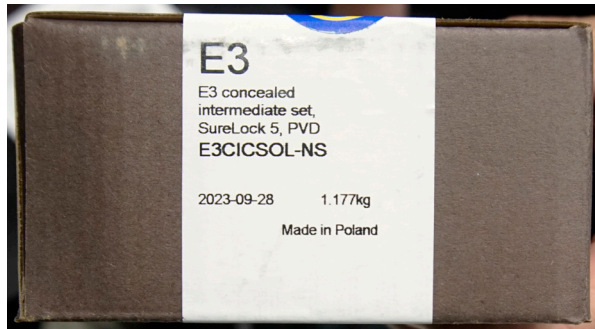

Back out screw ~ 3/16"



- B. **Set the height on all carrier sets.** To do this, screw the post all the way up until it bottoms out. Count 8 full rotations down or adjust enough so the top of the leaf is 1/2" down from the base. If the screws are backed out properly there should be roughly 10 rotations down. Stop at the 8th full turn. This will allow proper clearance and ability to adjust up or down later if needed.

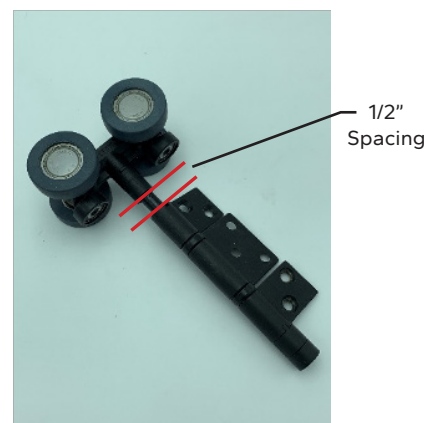
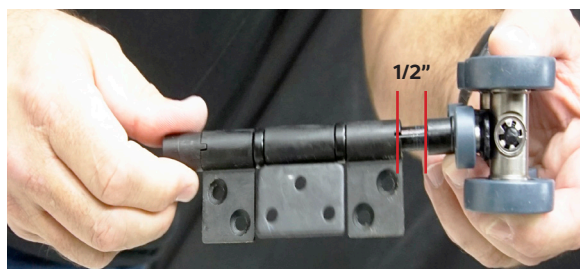



# 4 Hardware Preparation/Set-Up/Installation (continued):

**NOTICE** Use the hardware placement sheet provided in the hardware box for the following steps on the next few pages.

- C. **Install all the carrier rollers into the frame.** The style of door being installed will determine the order the hardware is put in. If the door set up has any group of panels ending on an even number, there will be a directional carrier set of hardware. If so, this roller will need to go in first. Install the roller into the hole routed out on the stacking side of the frame. The horizontal wheel side goes in first. All the other intermediate carrier sets will be installed in the same routed out hole.



- D. **Prep the concealed pivot set.** If needed, reverse the handing of the pivot block. Remove the top set screw.

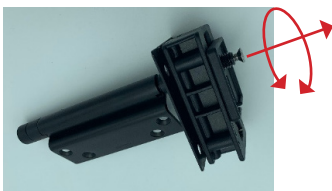
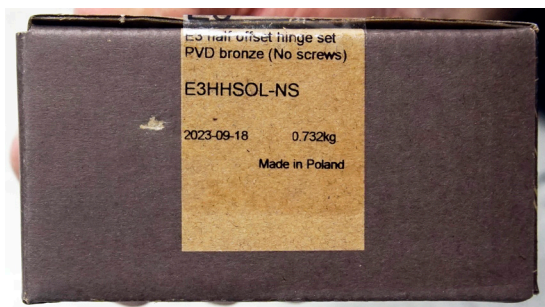

# 4 Hardware Preparation/Set-Up/Installation (continued):

E. Unscrew the post completely off the block, then flip the leaf and put it back together in the reverse order.



F. After the block is put back together it is necessary to back that top set screw out about 3/16". This will allow the post to be lowered enough for proper clearance.

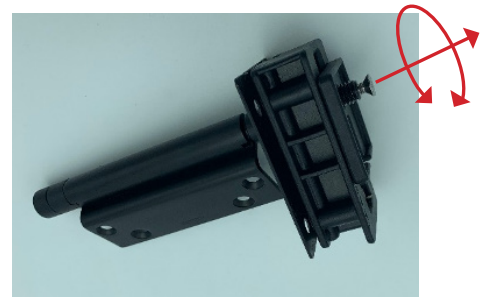

Back out screw ~ 3/16"

G. On the top block pivot, use the side-to-side adjustment screw to move the top portion of the block about 1/4" away from the block's edge. This will give clearance to install the block into the opening of the frame.

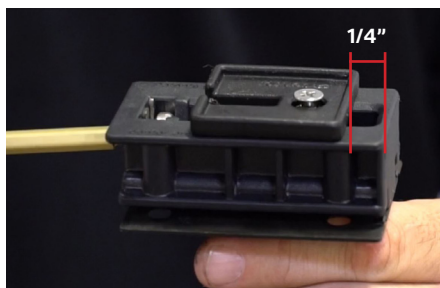
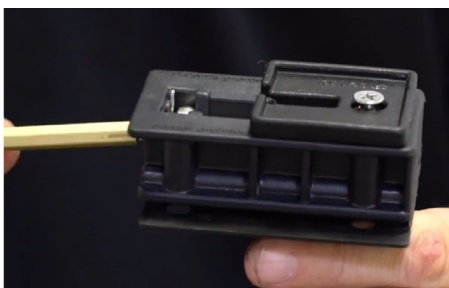

**NOTICE** Make sure the adjustment screw head is in the slot shown for any adjustment to be done after pivot set is installed in the track.





## 4 Hardware Preparation/Set-Up/Installation (continued):

H. **Set the height of the pivot set.** To do this, screw the post all the way up until it bottoms out. Count 8 full rotations down or adjust enough so the top of the leaf is 1/2" down from the base. If the screws are backed out properly there should be roughly ten (10) rotations down. Stop at the 8th full turn. This will allow proper clearance and ability to adjust up or down later if needed.

1/2"  
Spacing

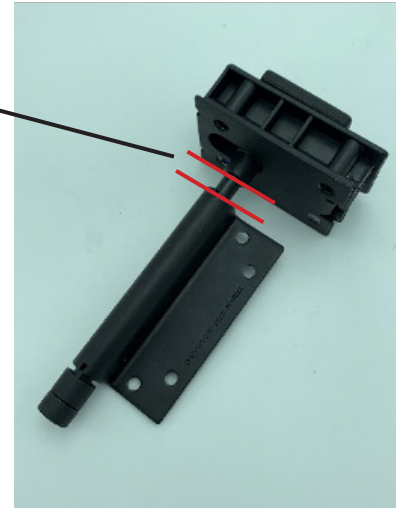

I. **Once all the carriers are in the top track,** install the pivot hardware block. Slide the metal plate down and install the face with the side-to-side adjustment screw into the routed out hole first.



J. **There will be 4 screws bagged up with one silver pan head screw.** The 4 screws will be used for the top block pivot. The silver pan head screw will be used for the bottom pivot. Make sure the pivot block is set in the track evenly and flat; use the plate screws to draw the block down into the grooves. The hinge post should be straight up and down and side to side.

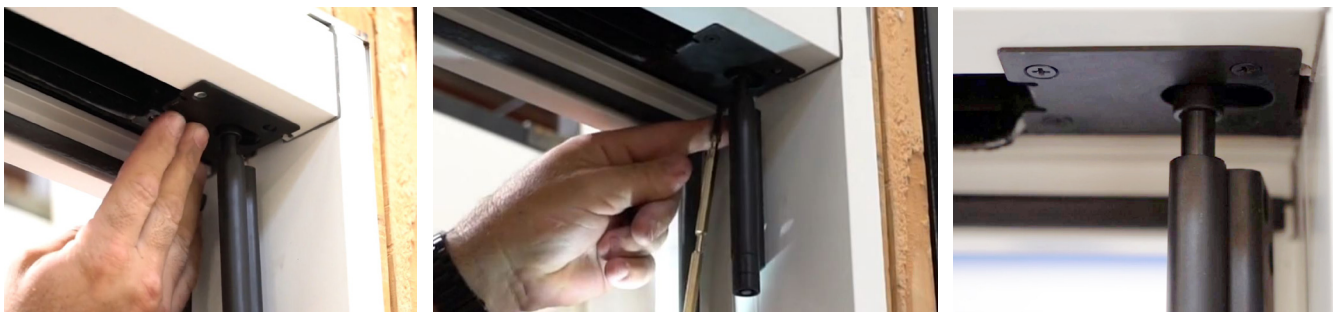

K. **The bottom pivot has 3 parts.** The main post with the adjustment screw threaded into it, and a 2-piece pivot block which is bagged up with one silver pan head screw that is used to secure the bigger portion block.



# 4 Hardware Preparation/Set-Up/Installation (continued):

- L. **Reversing the handing of the bottom pivot.**  
Unscrew the adjustment screw and place it on the opposite end of the post.

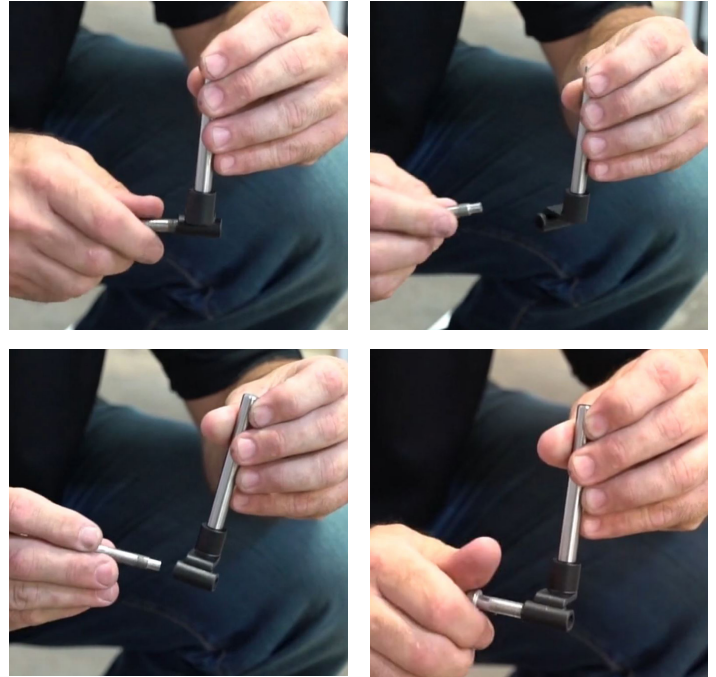

- M. **First install the larger portion of the bottom block into the bottom corner** where the panels will stack. This block needs to be pushed completely against the jamb. Either use a 9/64 drill bit or a self-tapping screw to pre-drill/start both bottom block holes.



- N. **Remove the bottom block and fill the holes with sealant.**





## 4 Hardware Preparation/Set-Up/Installation (continued):

- O. **Reinstall the bottom block against the jamb** and secure the block in place with the silver pan head screw which is in the bag with the 4 top pivot screws. Only secure the hole closest to the jamb, the other hole will be used in the next step.

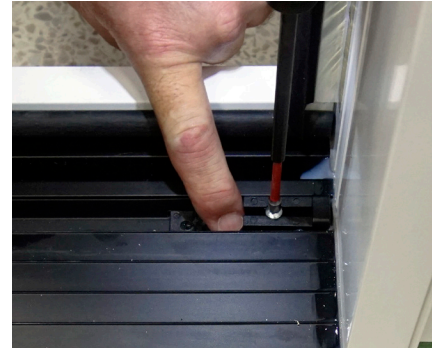

- P. **Snap the smaller block over the adjustment screw on the post.** Slide the back of the post onto the block. The back portion of the block should fit tight against the larger block. If it does not, turn the adjustment screw to move the blocks together. Use the silver pan head screw provided in the bag with the bottom block to secure the bottom pivot into place.

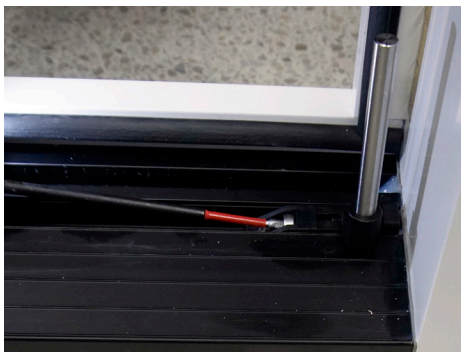
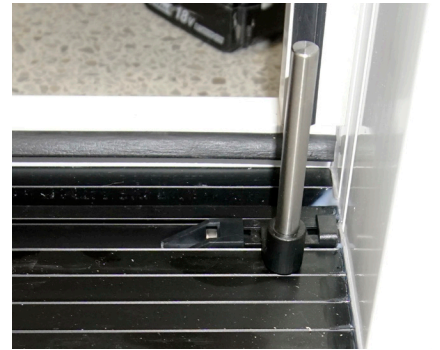

# Tall Door Information:

## WALL PIVOT

If the door is 90" or taller there will be wall pivot hardware. Depending on how tight the framing is to the frame, it may be necessary to drill (3/4" bit) out the framing through the wall pivot hole. The sleeve on the wall pivot will extend 3/8" past the frame. Use the Hinge Screws provided to install the wall pivot sleeve in the frame.

On the stacking side jamb, there are some holes drilled out around the middle of the jamb. Install the wall pivot sleeve into this hole. Use the hinge screws provided to secure into place.

- Figure out what part of the leaf is the top. Using a mallet, hammer the button plug onto the top.
- Secure the leaf onto the middle section of the first installed panel.
- Slide the bottom leaf over the bottom pivot post.
- Stand the panel straight up while sliding the wall pivots L-shaped piece into the middle hinge and the other end of the L-shaped post into the jamb sleeve.
- Secure that panel to the top pivot leaf.



## EXTERNAL PULL HANDLE

On taller doors there will be an External Pull Handle. This is usually only needed on doors with 4 hinge placements or windows, but not limited to. The pull handle should be mounted about 1" above the twin bolt handle. The placement will vary depending on where the hinges are placed on the panel from the manufacture. The handle will need to be drilled out on site. Use a #17 drill bit. **Use the 1" hinge screws supplied.**



**1" screws are needed if the door has a hinge positioned next to the twin bolt. There should be a pack of 1" hinge screws supplied with the external pull handle.**

**These screws MUST be used on any hinge that is lined up with the twin bolt handle mounted on the same panel. Failure to do so will damage the twin bolt mechanism.**

# 5 Panel Installation:

IN THE MAIN BOX OF HARDWARE, WILL BE A HANDING SHEET FOR THE PARTICULAR DOOR. THIS SHEET WILL DETAIL THE LOCATION OF EACH PIECE OF HINGE HARDWARE.

Each panel will be numbered to help configure which panels go where. Not always will the #1 panel be the first panel hung in the frame. The panel started with depends on what handing the door is.

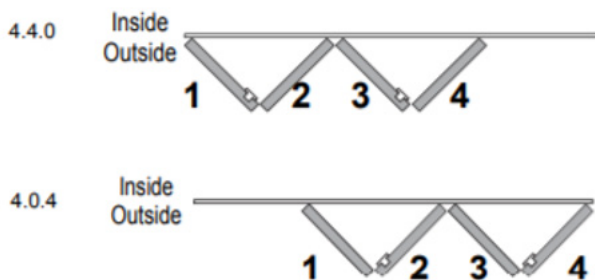

### NOTICE

- Panel numbering is always left to right.
- After the frame is installed per instructions above, always start with the pivot side first.
- Do not open the hardware boxes arbitrarily to prevent mixing the hardware up.

**NOTICE** Hinge screws are provided in the main box. Each panel comes with a Philips head alignment screw used to keep the center aluminum channel in place during shipping. These screws MUST be removed prior to installing the hardware on each panel. These screws are located on the top hinge holes.

A. The only parts left in the pivot box should be the bottom leaf and the button plug. Identify which way the leaf will mount to the first panel to see which side will be the top of the leaf. Using a mallet, hammer on the button plug to the top of the bottom leaf.



B. Attach the bottom leaf to the bottom of the starting panel.

**TIP** - When attaching the hinges to the panels, always install the hinge screws which are closest to the edge of the panel first.





# 5 Panel Installation (continued):

**NOTICE** To make installing the panels easier, it's suggested to use some shim material roughly 5/8" to set the panels on while installing each panel.



**NOTICE** Each panel comes with a Philips head alignment screw in the top hinge location used to keep the center aluminum channel in place during shipping. These screws must be removed prior to installing the hinge hardware on each panel.

Remove this screw

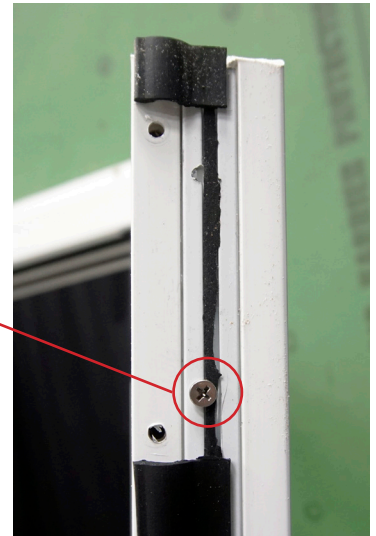

C. Install the first stacking panel by sliding the bottom leaf over the pivot post, rest the panel on the shim material.





# 5 Panel Installation (continued):

- D. Remove the screw in the top hinge location.

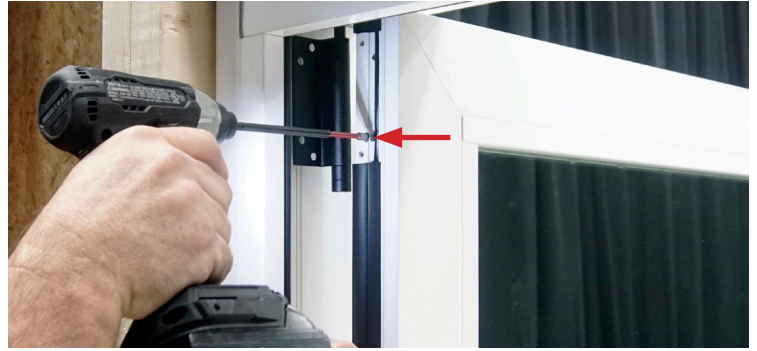

- E. Keep the panel perpendicular to the frame and screw the top pivot block leaf into the panel.

TIP - When attaching the hinges to the panels, always install the hinges screws which are closest to the edge of the panel first.

When installing the hinges screws closer to the center of the panel, the screws may need to be angled slightly to locate the pre-drilled holes in the aluminum support.

Using the supplied hardware placement sheet continue hanging the panels with the corresponding hinge sets.



- F. Identify the offset hinges to be installed on the first installed panel. Follow instruction for the correct hinge parts and where they should be placed.

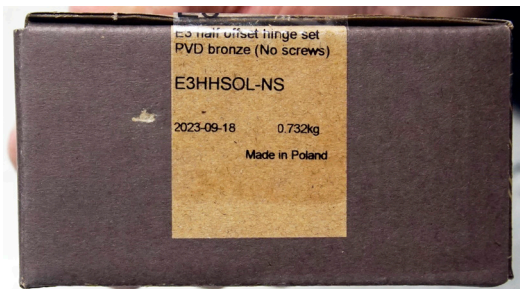

Offset Hinge      Straight Hinge

# 5 Panel Installation (continued):

G. Mount the offset hinges on the first installed panel.



H. Set the second panel to be installed, face to face with the first panel. Mirror the panels, interior to interior/glazing bead side to glazing bead side. Place the second panel on top of the shims on the sill.



I. Remove the screw in the top hinge location. Attach the panel to the offset hinges with screws.

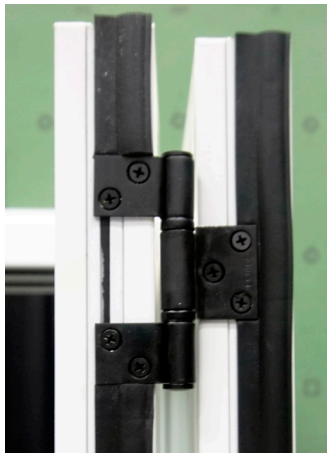
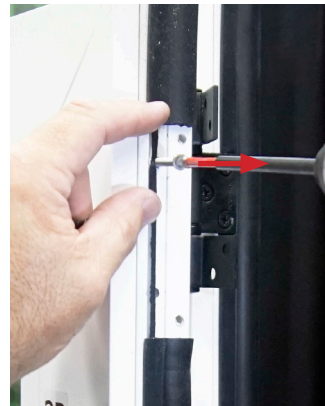



# 5 Panel Installation (continued):

J. Position the carrier set next to the second panel and remove the screw in the top hinge location.



K. Attach the carrier set to the second panel and install the other hinges from the intermediate carrier box.

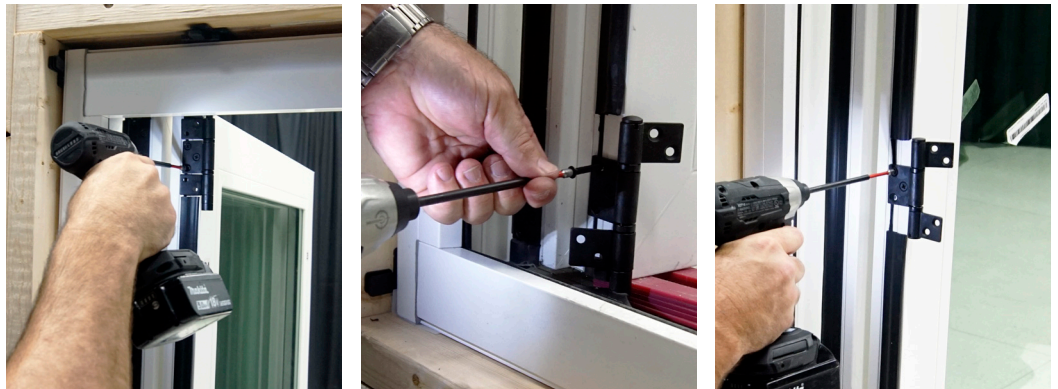

L. Using the supplied hardware placement sheet, continue hanging the panels with the corresponding hinge sets.

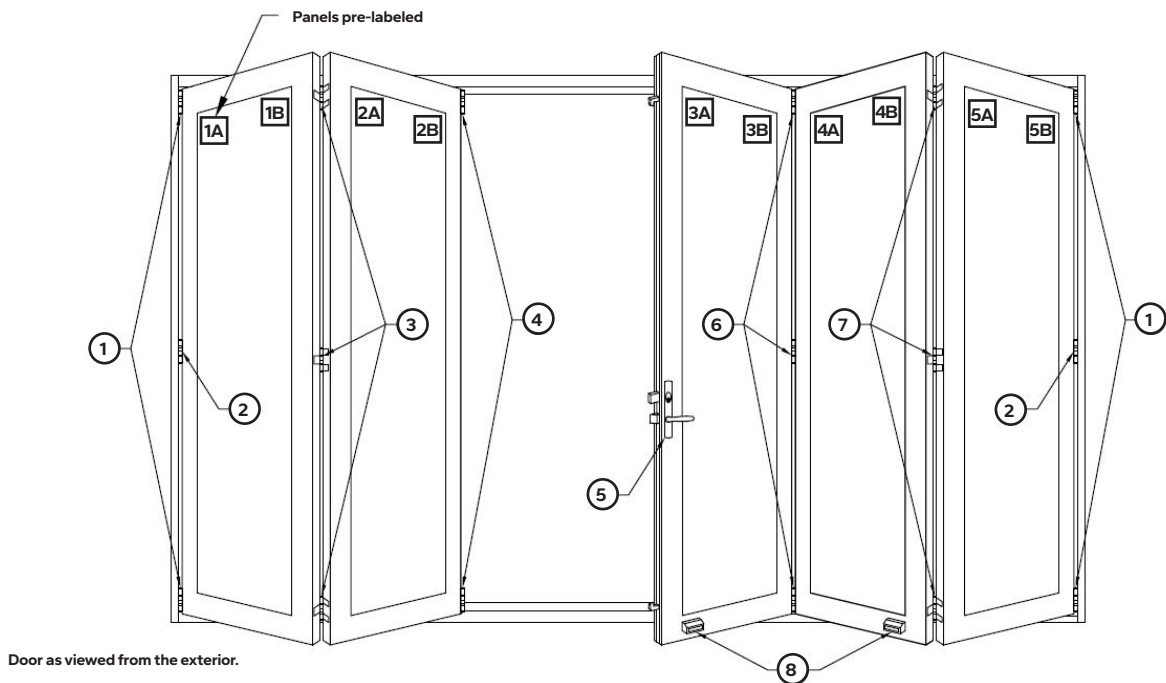

# 6 Folding Window:

There are a couple differences when it comes to a Folding Window and a Folding Door.

1. There will not be handle hardware with the deadbolt and multi point lock. Instead, it is just a handle to engage a twin bolt that will lock the window.
2. There is a Folding Window Jamb extender with euro cap. This piece will need to be installed after the frame is completely installed but before the final adjustments are done on the window panels.

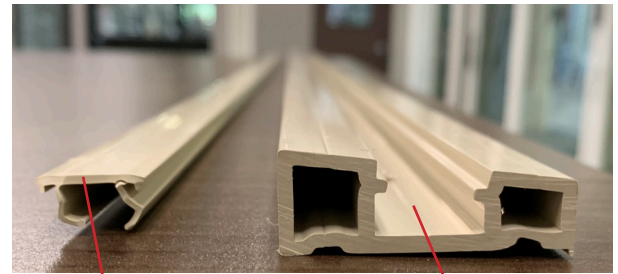

Euro Cap

Jamb Extender

**NOTICE** There may be extra hinges not needed depending on the height of the window. Follow the hardware placement sheet to make sure the correct hardware is in the proper place.

## Jamb Extender

A jamb extender with euro cap is supplied with the window. The purpose of this extender is to allow clearance for the handle to operate properly. This will be used on odd number panel windows stacking to one side.

- The extender should be mounted with the widest edge towards the jamb stop.
- It should be about 1/4" away from the jamb stop.
- Use the self tapping strike plate screws supplied. Place screws 3" from the top and bottom and every 16" between.
- Once installed, install the euro cap to cover the screws. Pinch the top of the legs to make the install of the cap easier.

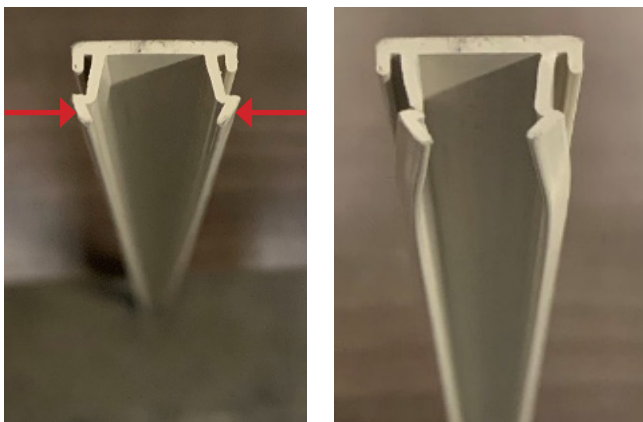

# 6 Folding Window (continued):

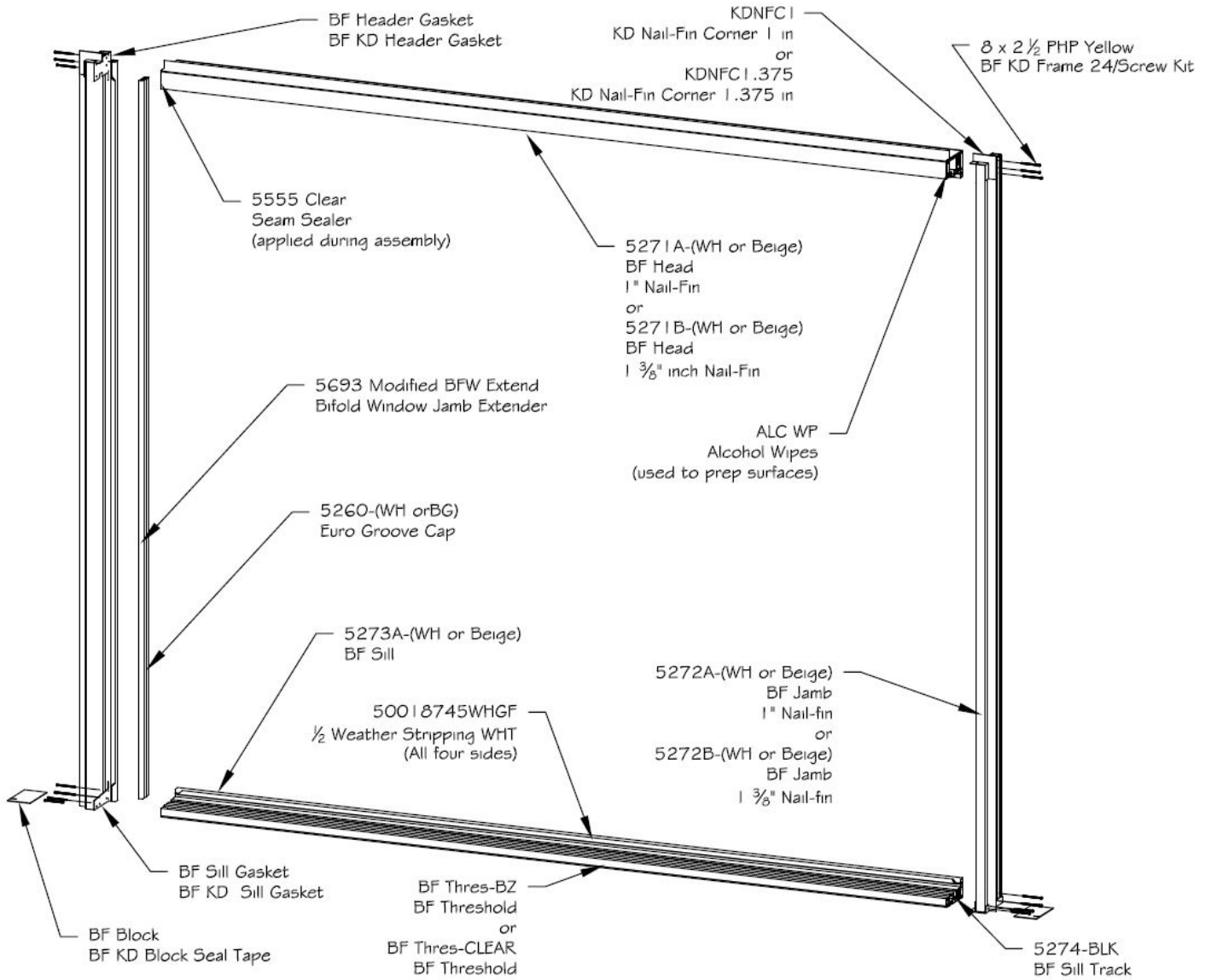

# Low Profile Sill Installation:

**NOTICE** The low profile sill is not able to withstand air and water intrusion like the weather resistant sill. This option has no weep or drainage incorporated into the track; therefore, an overhang is important for protection over this type of sill. Confirm compliance with any project accessibility requirements with the project's design professional or local building code official.

## Finished Floor Option 1

It will be necessary to notch the flooring in order for the threshold to sit flat with a smooth transition. The guide track of the low profile threshold protrudes lower than the portion of the sill that will sit on the finished floor. The dimensions of this guide channel are 7/16" tall and 1" wide.

Mark where this will sit and cut a notch in the finished floor. It's suggested to make the notch 9/16" deep and 1-1/4" wide.

## Unfinished Floor Option 2

The finished height of the flooring is needed before continuing. Once the height of the finished floor is obtained, determine if it's necessary to notch the threshold's substrate. Any finished floor that exceeds 1/2" will most likely not need any extra work on the threshold. In this case put some sort of furring strips, (material that will be weather resistant and not rot) the height of the proposed finished floor, under the floating interior and exterior edge of the threshold. This should leave enough room so the new flooring can be maneuvered partially under the low profile threshold creating a smooth transition, flooring to threshold.

If the flooring is thinner than 1/2", follow the steps on the Finished Floor Option 1, but only at the difference of the overall guide depth minus the actual finished floor.

### Option #1 (1" Nail Fin)

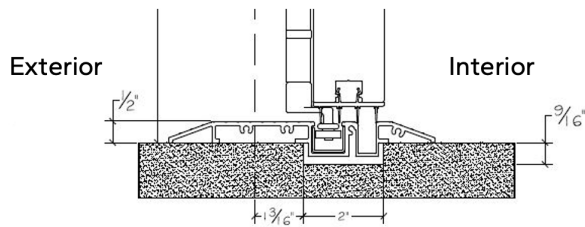

### Option #2 (1" Nail Fin)

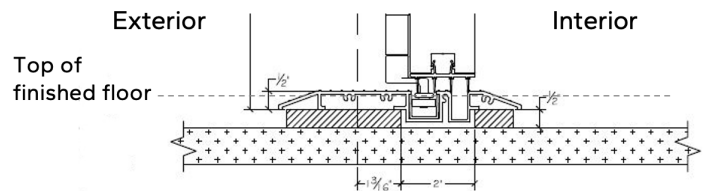

### Option #1 (1-3/8 inch Nail Fin)

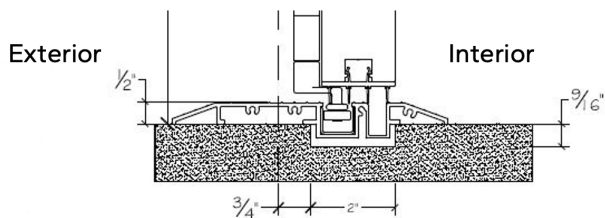

### Option #2 (1-3/8 inch Nail Fin)

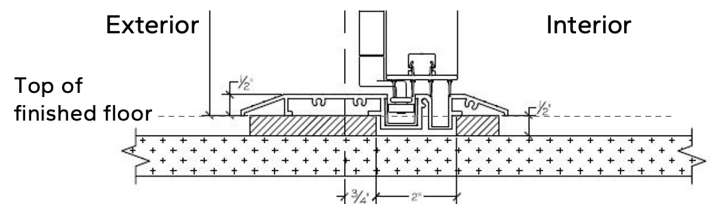

# Low Profile Sill Installation (continued):

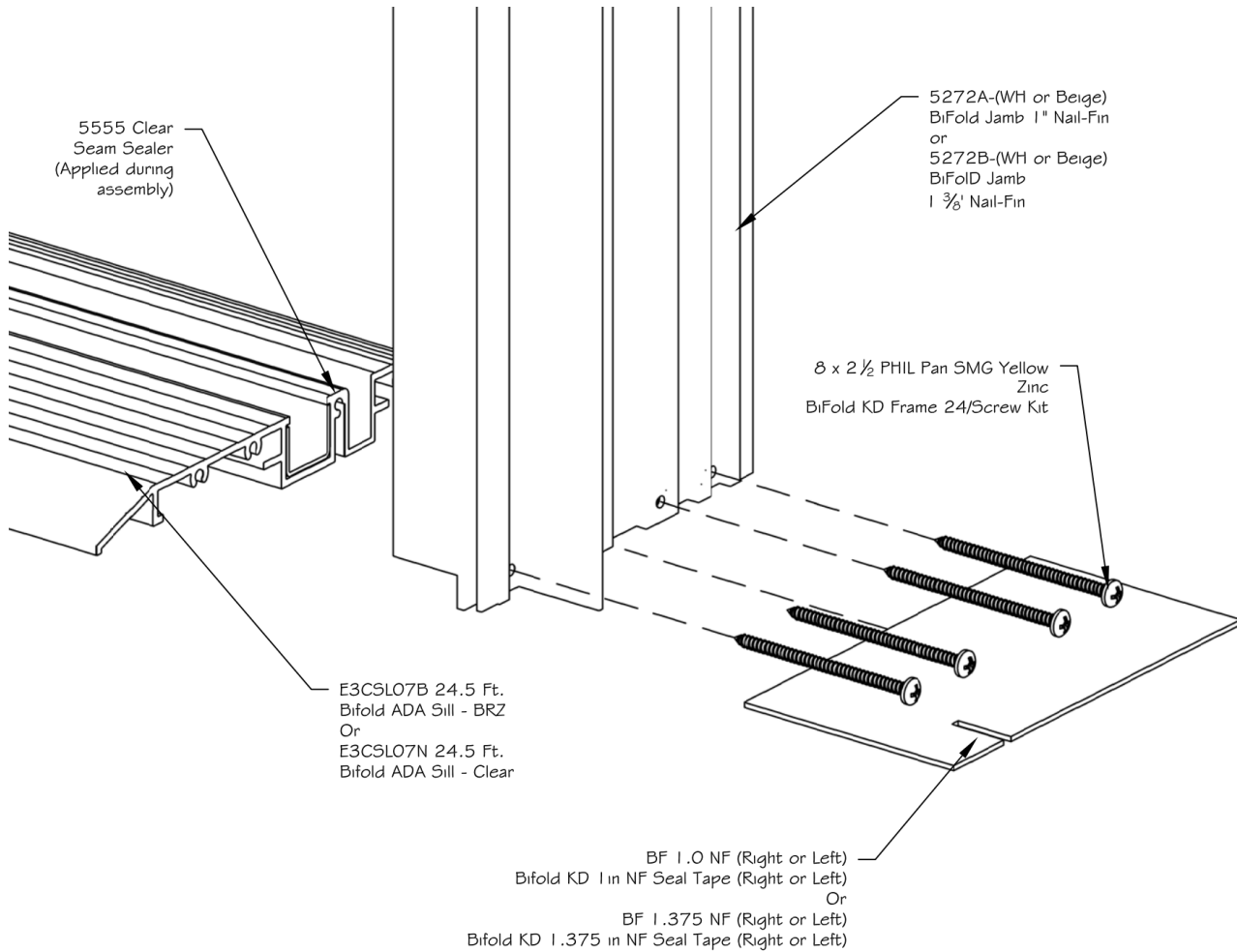



## 1" Nail Fin Set Back with Low Profile Sill

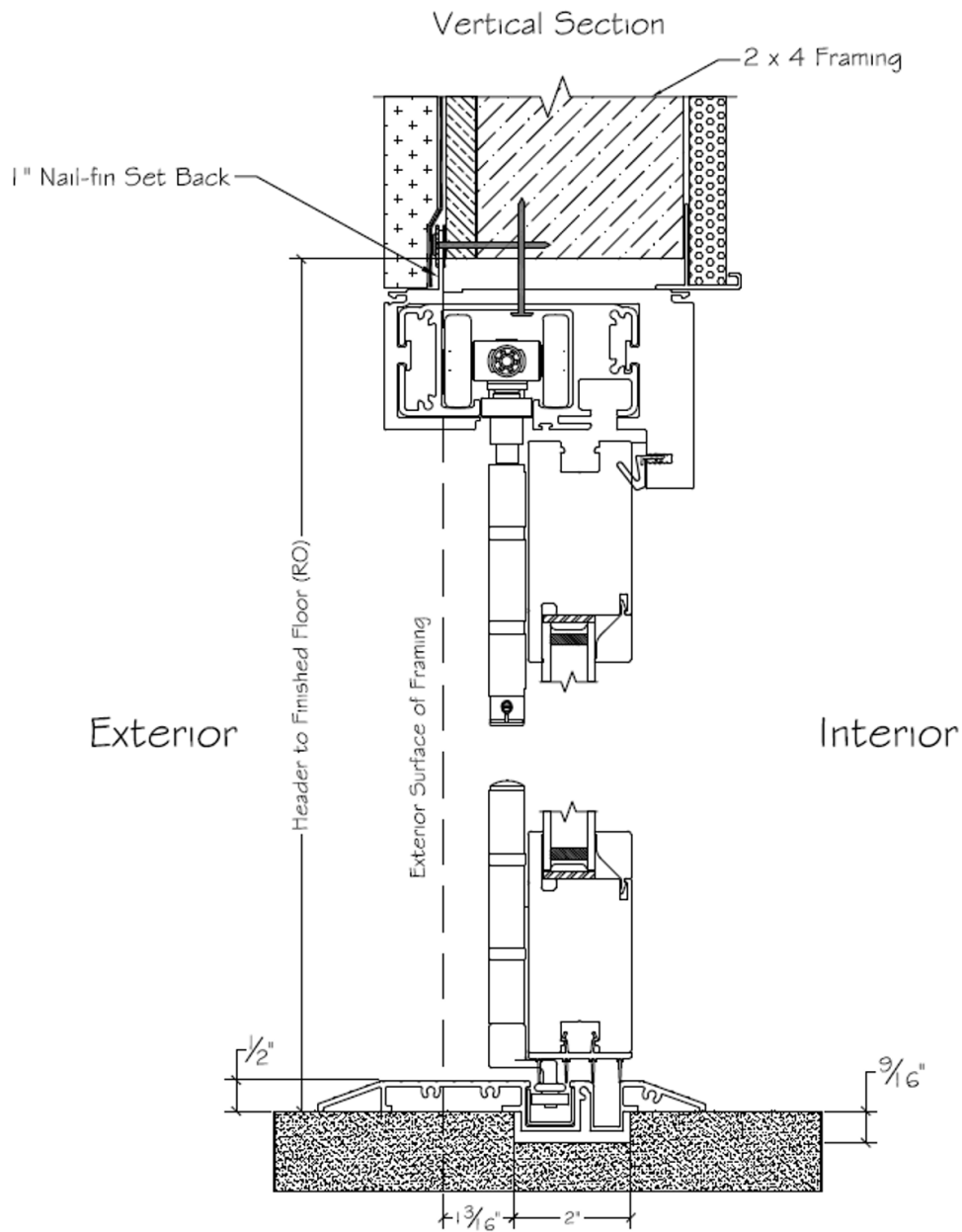

The exterior edge of the 2" groove is 1 3/16" from the exterior edge of the framing

A 2" x 9/16" notch needs to be created in the floor. This allows the ADA sill to sit on the finished surface. This drawing does not take into account: pans, membranes & sealant provided by others. The ADA sill are not able to withstand air & water intrusion like the weather resistant sill. This option has no weep or drainage incorporated into the track, therefore overhang and protection is important when using this sill. It is important that you include a mop zone adjacent to these doors when choosing this option. Sweep (included) is field applied.



## 1-3/8" Nail Fin Set Back with Low Profile

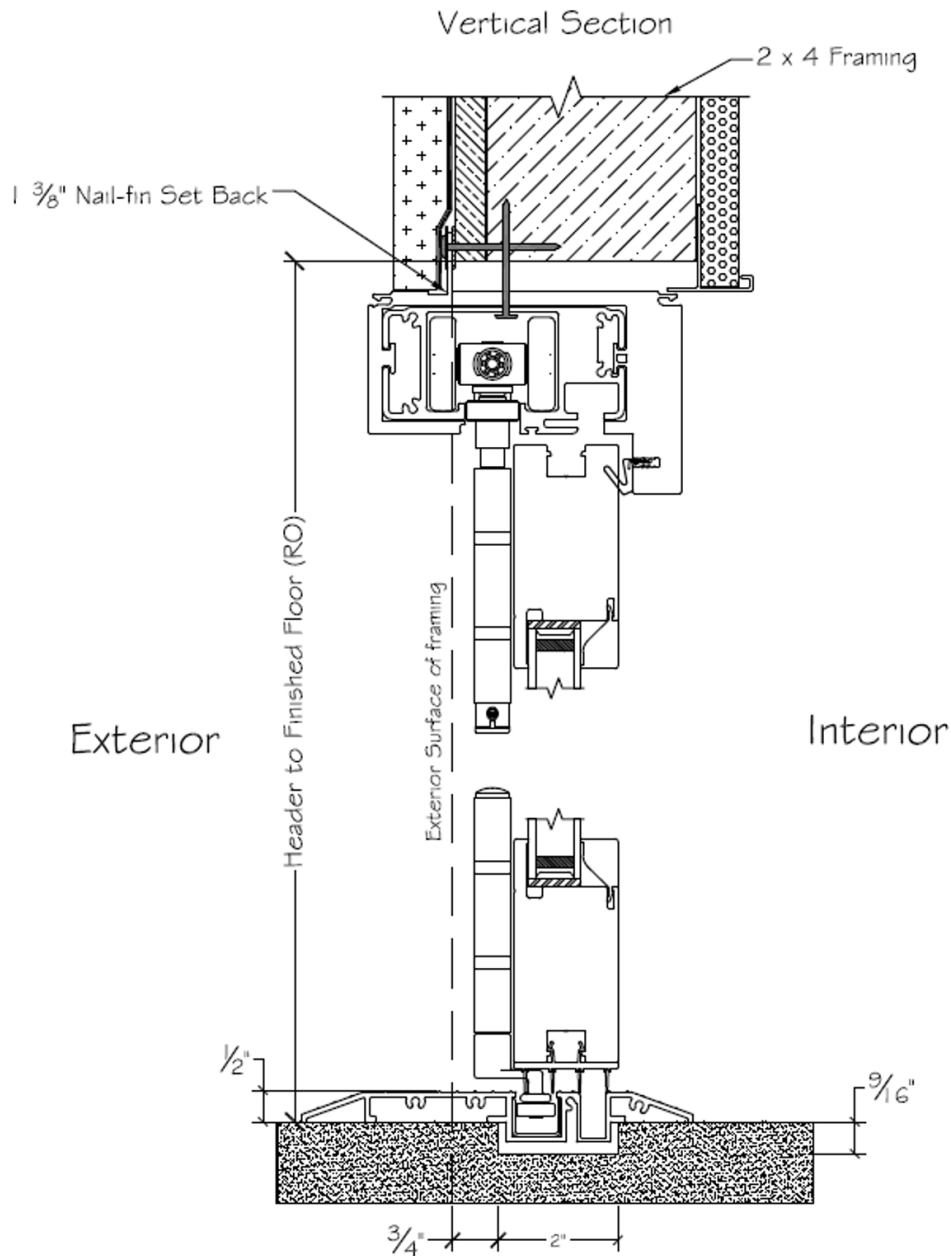

The exterior edge of the 2" groove is 3/4" from the exterior edge of the framing.

A 2" x 9/16" notch needs to be created into the floor. This allows the ADA sill to sit on the finished surface. This Drawing does not take into account: pans, membranes & sealant provided by others. The ADA sill are not able to withstand air & water intrusion like the weather resistant sill. This option has no weep or drainage incorporated into the track, therefore overhang and protection is important when using this sill. It is important that you include a mop zone adjacent to these doors when choosing this option. Sweep (included) is field applied.

# Flush Sill Installation:

**NOTICE** The flush sill is not able to withstand air and water intrusion like the weather resistant sill. This option has no weep or drainage incorporated into the track; therefore, an overhang is important for protection over this type of sill.

On a flush sill application, the frame will be 3-sided and with a U channel for the bottom (**do not cut the U channel**). This install requires knowing what the finished floor or countertop will be in order to determine where to set the height of the U channel.

Depending on the finished floor or counter, a notch may be needed to flush the sill to the level of the finished surface. Net size of the flush sill is  $15/16$ " wide by  $7/8$ " tall. If cutting a channel in a finished floor or counter, a  $1/8$ " gap around the sill is recommended to allow it to be adjusted accordingly.

The first step entails finding out where the U channel will sit. On a 1" nail fin the U channel will start  $1-3/16$ " from the face of the framing. On a  $1-3/8$ " nail fin the U channel will start  $13/16$ " from the face of the framing.

On an unfinished opening the dimensions of the proposed finished floor or counter will be needed, set the U channel at the appropriate height. On a door it is likely a notch will be necessary.

Flash the opening according to AAMA standards.

Set the U channel in the appropriate location.

Install the frame. The frame will sit on top of the U channel.

Continue with the frame and panel install on pages 14-21.

**NOTICE** A hole will need to be drilled in the finished floor or countertop for the twin bolt to lock.

**Option #1 (1" Nail Fin)**

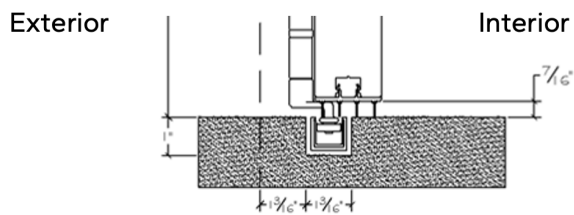

**Option #2 (1-3/8 inch Nail Fin)**

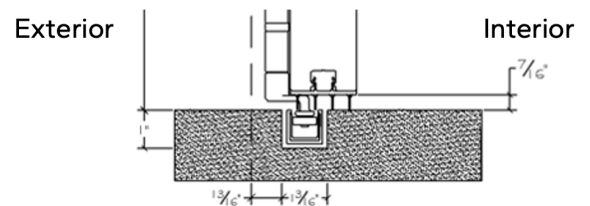

## 1" Nail Fin Set Back with Flush Sill

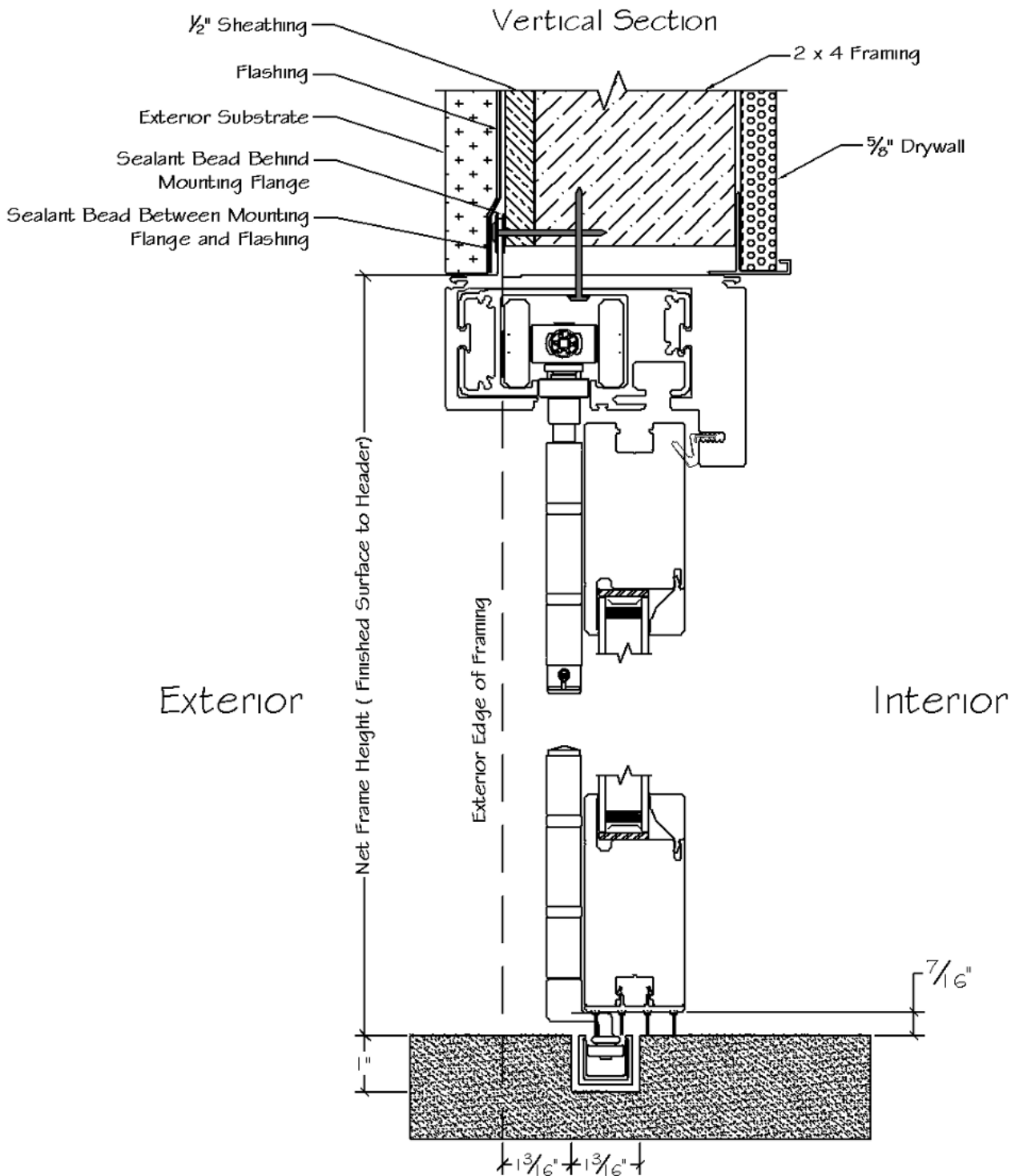

A 1 3/16" x 1" notch needs to be created in the floor. This allows the flush sill to be flushed to the level of the finished surface. Net size of the flush sill is 1 5/16" wide by 7/16" tall. This drawing shows an 1/8" gap around the sill to allow it to be adjusted accordingly. Drawing does not take into account: pans, membranes & sealant provided by others. The flush sill are not able to withstand air & water intrusion like the weather resistant sill. This option has no weep or drainage incorporated into the track, therefore overhang and protection is important when using this sill. It is important that you include a mop zone adjacent to these doors when choosing this option.

# 1-13/16" Nail Fin Set Back with Flush Sill

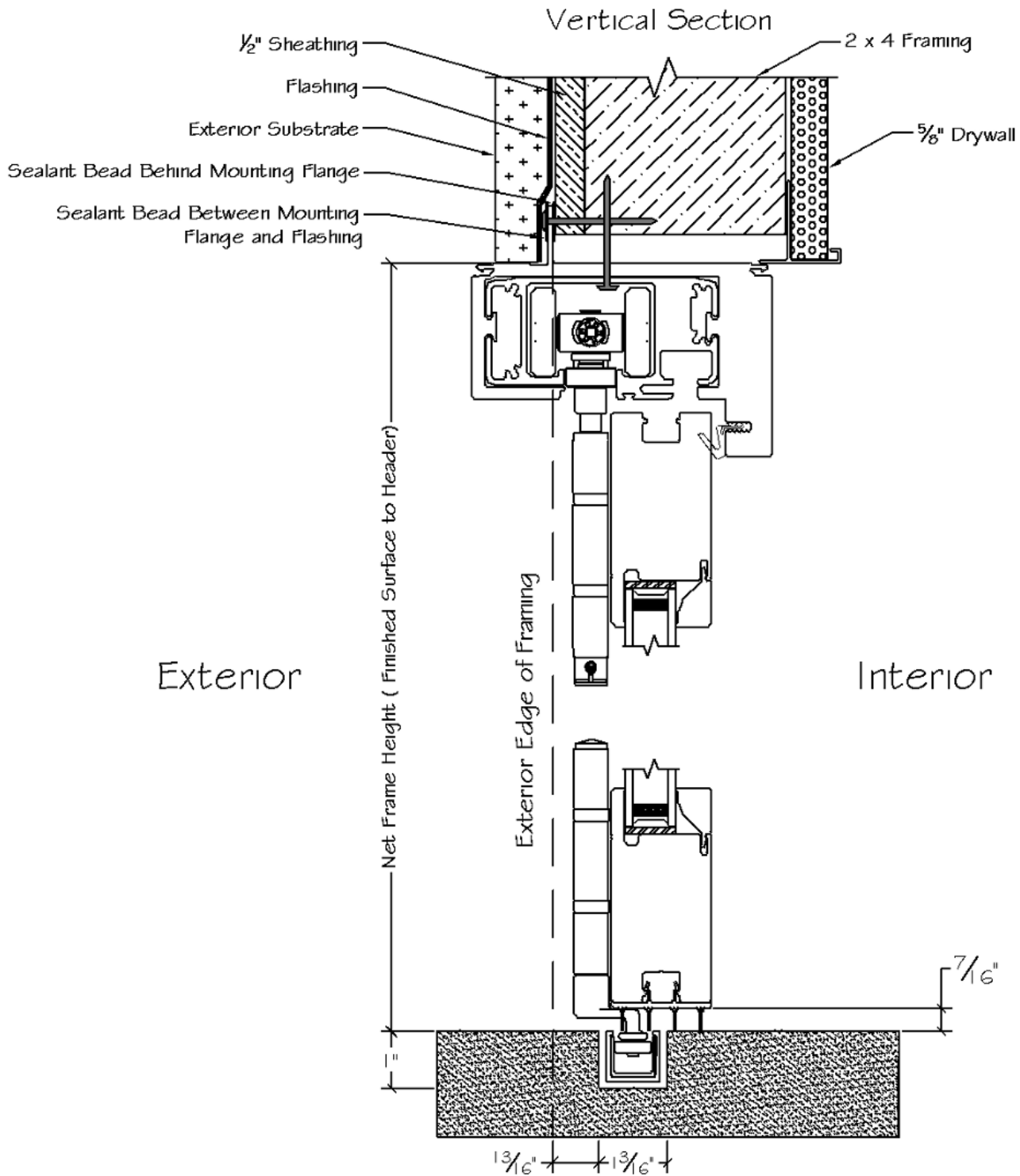

A 1 3/16" x 1" notch needs to be created in the floor. This allows the flush sill to be flushed to the level of the finished surface. Net size of the flush sill is 1 5/16" wide by 7/8" tall. This drawing shows an 1/8" + gap around the sill to allow it to be adjusted accordingly. Drawing does not take into account: pans, membranes & sealant provided by others. The flush sill are not able to withstand air & water intrusion like the weather resistant sill. This option has no weep or drainage incorporated into the track, therefore overhang and protection is important when using this sill. It is important that you include a mop zone adjacent to these doors when choosing this option.

# Astragal and Directional Carrier Assembly Installation:

Doors with a stack of an even number of panels, with an astragal mounted to the panel, will require a few extra steps to install the directional carrier hardware.

1. Remove the strike plates if any are installed on the astragal.
2. Carefully remove the euro caps that are between the strike plates. Make sure to mark which one goes where. These mount in specific places.
3. Remove all the screws behind those caps.
4. Set the astragal aside.
5. Align the directional carrier set and screw the top and bottom hinges in place.
6. Before applying the astragal to the sash panel, make sure the sash is adjusted properly. Once the adjustment is made, dry fit the astragal over the edge of the sash making sure the slot on the astragal lines up with the carrier. It may be necessary to modify the astragal.
7. After dry fitting, apply silicone to the face of the astragal that will mate up with the panel.
8. Re-screw the astragal on, just as it was taken off.
9. Screw in place the 3 strike plates if they were originally installed.
10. Snap in the euro caps in the correct spots.

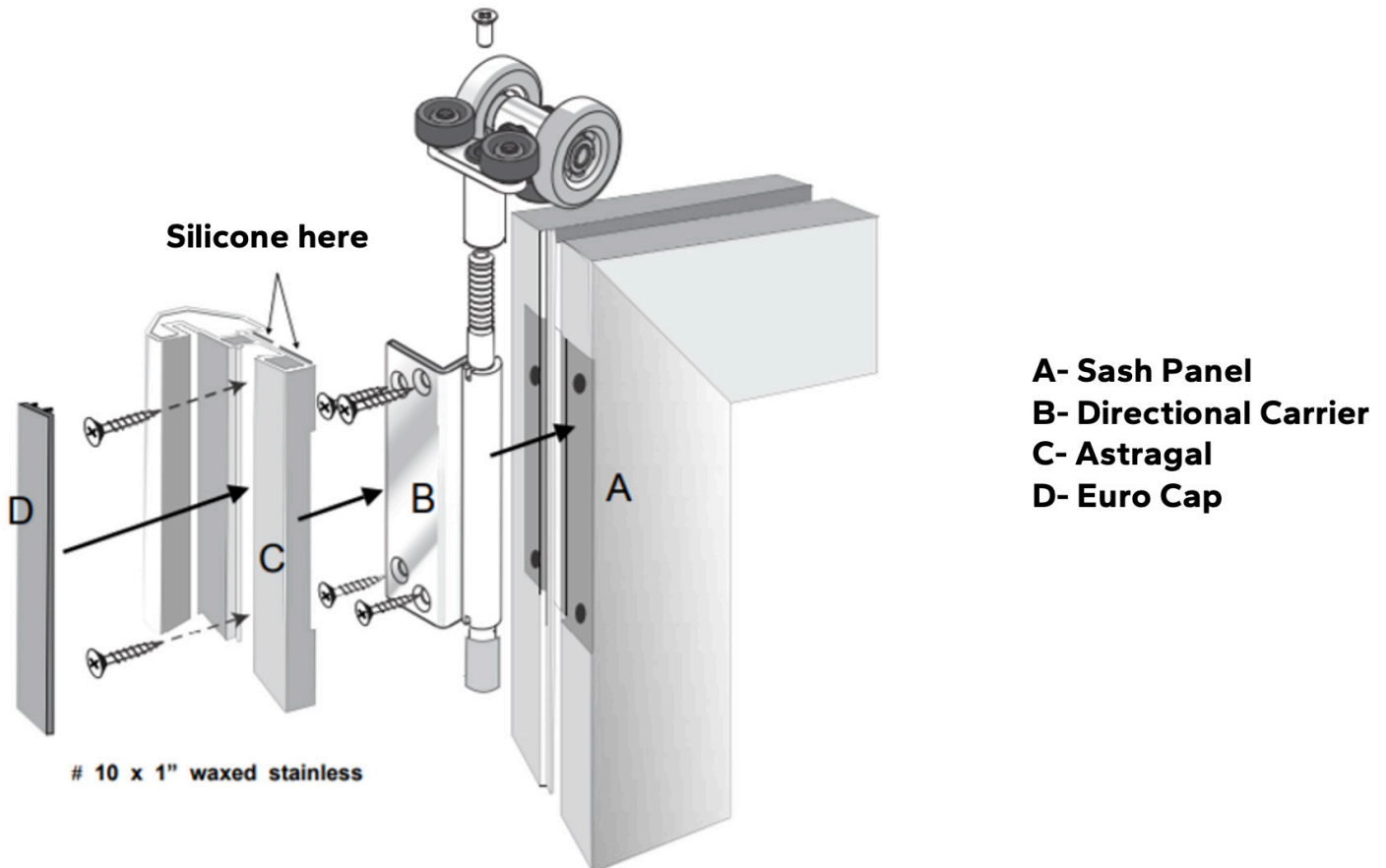



# 7 Handle Hardware Installation:

- A. Position each escutcheon plate with the **onto each side of the panel**. The plate with the thumbturn goes on the interior side of the panel.

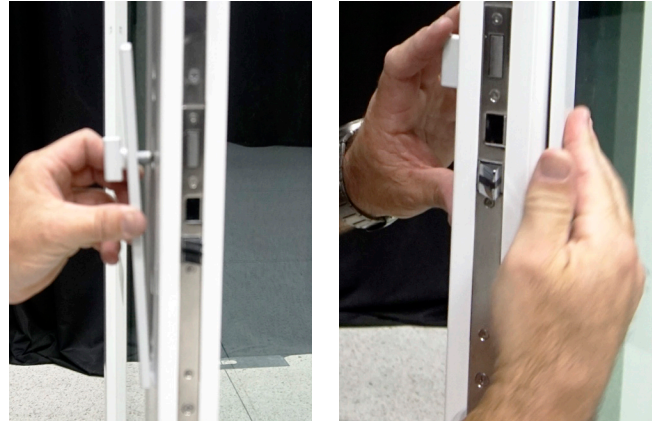

- B. Insert and tighten the two attachment screws.



- C. **Insert the two-piece spindle into one of the handles.** Insert and tighten the set screw with the provided Allen wrench. The set screw must be flush or below the handle surface when fully tightened.

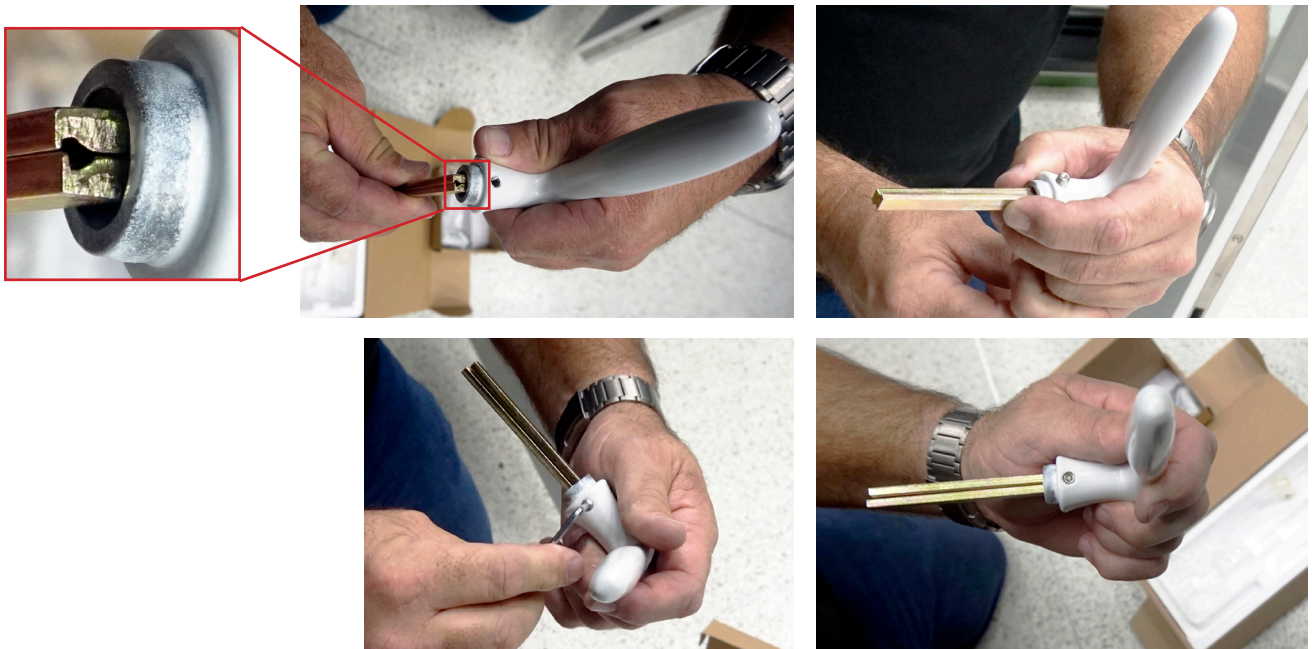

# 7 Handle Hardware Installation (continued):

- D. **Position the bushing over the spindle and against the back of the handle.** Install the handle onto the panel through the handle hole in the escutcheon plate and up tight against the plate.



- E. **Position the bushing onto the back of the other handle.** Insert the set screw.



- F. **Position the other handle onto the spindle** and make sure both handles are tight against the respective escutcheon plates. Tighten the set screw until it is flush or below the surface of the handle.





# 7 Handle Hardware Installation (continued):

G. Close the door panel and lock and unlock the hardware a few times to confirm it is working properly.

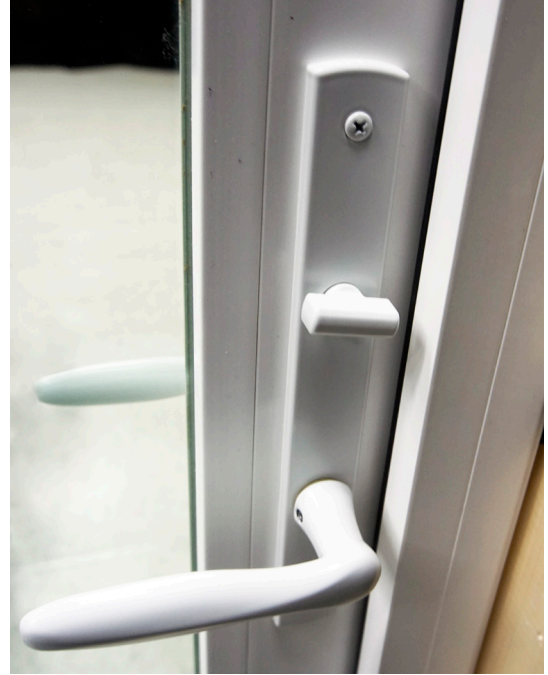

# 8 Panel Adjustments:

Once the panels are set, look at the reveals and adjust the panels if needed.

A. **Completely shut the entire door.** Check the jamb reveal on the pivot side, then check the strike side jamb reveal. Center the group of panels in the frame. Take a look at the top head to panel reveals. This should be set just right if not extremely close, if the hardware preparation section was followed correctly. There should be an even space across the length of it, with a slightly larger gap in the middle due to the crowning of the head.

B. **If the head reveal is off as well as the jamb reveal,** raise or lower a carrier roller or pivot and/or adjust the 2 pivot side-to-side adjustments.

C. **The most important reveal is the strike side.** If the reveal is too small the panel will knock and if the gap is too wide, then the latches won't engage properly. An optimal gap would be 1/4".

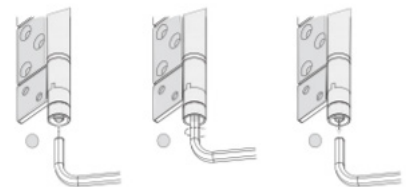
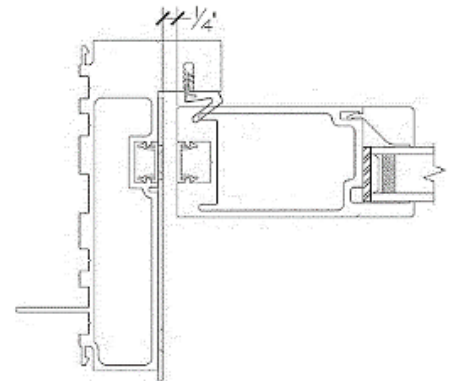
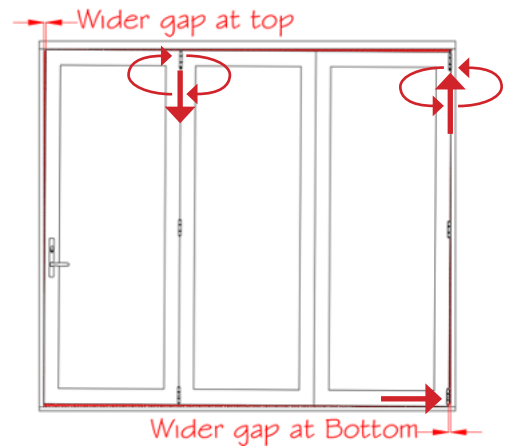
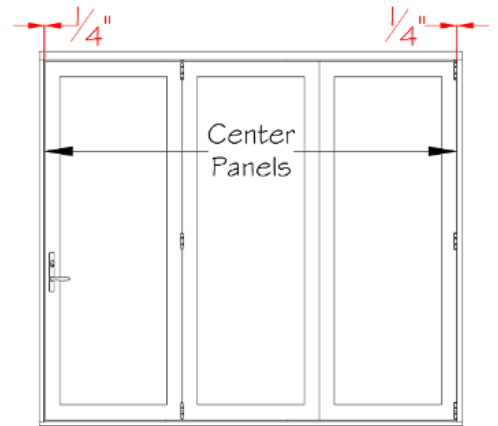

Adjustments can be made with one hand using an 5/16" (8mm) Allen key.

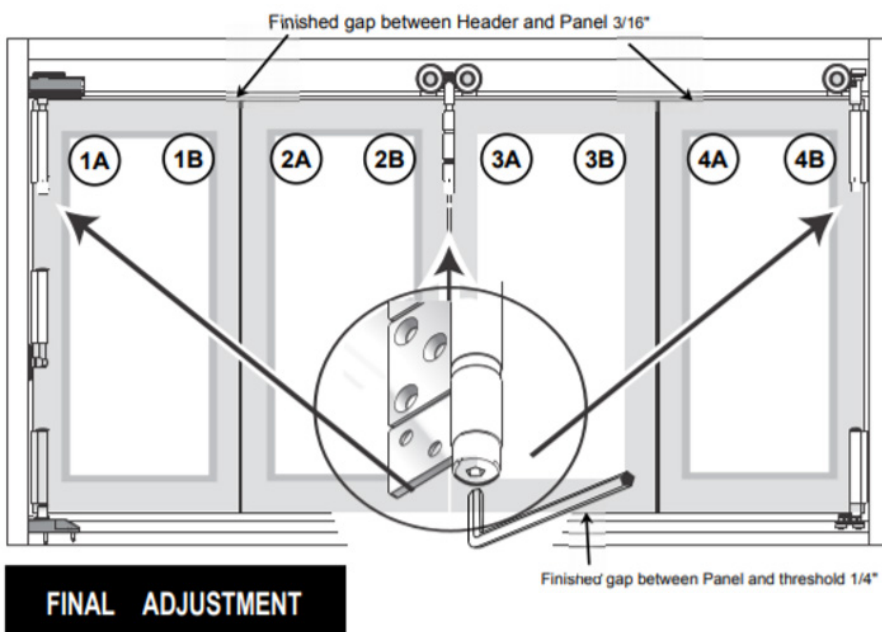



## 8 Panel Adjustments (continued):

- D. To adjust the side-to-side adjustments, open the door completely and use a Philips handheld screwdriver. The adjustments will be in both the top pivot block and the bottom pivot block.

### Panel Adjustment

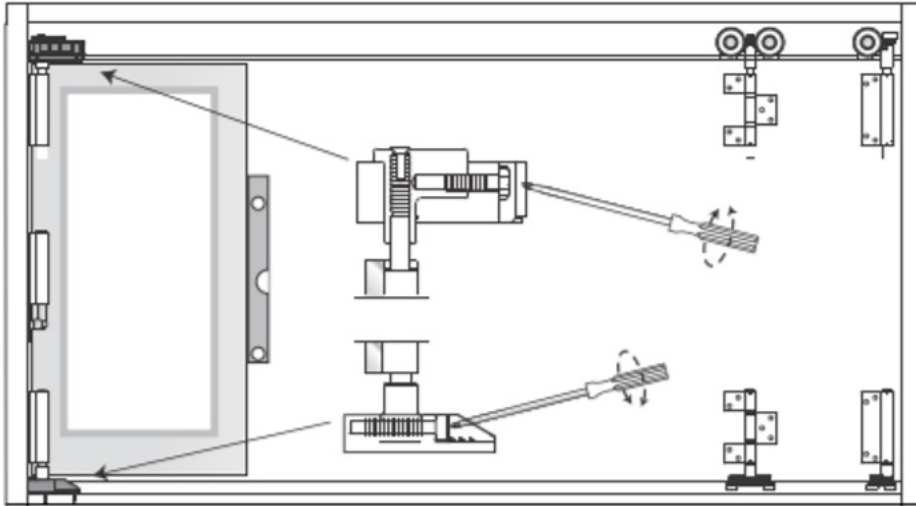

**NOTICE** 3/8" gap on each side of the panel to frame is acceptable. The weatherstrip will still have sufficient contact with the panel. If on any door the jamb side gaps exceed 3/8" then it is necessary to use the provided hinge leaf shims. (See *hinge shimming* section page 6.)

- E. Install the handle hardware on the main active panel. (See *folding door handle hardware and latch bolt reversal* page 7.)

# 9 Strike Plate Installation:

In the hardware box are 3 keeper plates; 1 large for the strike and deadbolt, 2 for the hook locks and attachment screws.



A. **Close the main active panel** with the handle hardware on it. Lift the handle to engage the hook locks and dead bolt.

B. **With a pencil**, mark the bottom most point of where the top hook lock stops when engaged.



C. **With a pencil**, mark the top and bottom of where the dead bolt engages in the jamb.

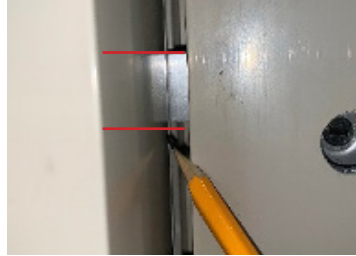

D. **With a pencil**, mark the top point of where the bottom hook lock stops when engaged.

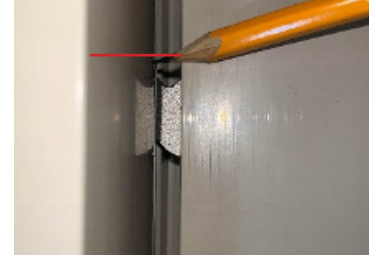

E. **Align the top hook lock strike plate** with the bottom edge of the opening about 1/8" below the pencil mark. Using a 9/64" drill bit, pre-drill the two holes and secure the hook strike plate with the screws.

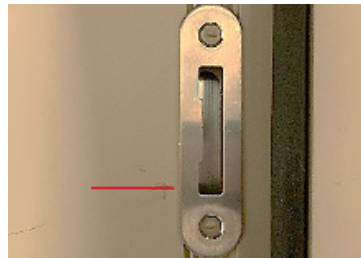

F. **Place the main strike plate on the jamb** where the top and bottom marks of the deadbolt are visible through the deadbolt hole on the strike plate. Holding the strike plate in place, mark the top edge of the plate. Using that line for the placement of the strike plate, slide the plate towards the stop till the holes are flush with the routed-out holes. The holes for the tongue and dead bolts exterior edge should be about flush with the routed-out vinyl. Align the plate with the top line and holes flush with the routed-out vinyl, mark where to pre-drill for the holes.

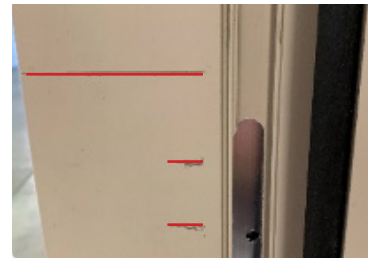
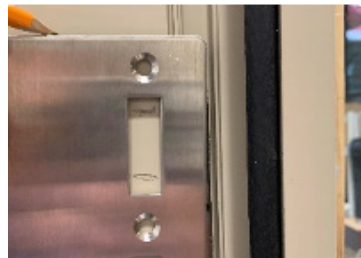

G. **Pre-drill the holes with a 9/64" bit and secure the plate.**



# 9 Strike Plate Installation (continued):

H. **Install the bottom hook lock strike plate** with the top edge of the opening about 1/8 inch above the pencil mark. Using a 9/64" drill bit, predrill the two holes and secure the hook plate.



I. **To ensure the product is working properly**, start by closing the panel and engage every locking point. Go through opening, closing, and locking multiple times to ensure everything is aligned and working smoothly.

**Once all the locks are working properly and are completely screwed in and secured, make sure to put shims behind every keeper to eliminate any movement from the operation of the door.**

# 10 Strike Side Cap Installation:

A. **On every keeper back out each screw** but do not fully remove.

B. **Place the jamb cap where it will be installed.** Next, mark on the cap where each screw begins; slightly above the top screw, but below the bottom screw of the keeper.



Discard



C. **Cut the cap at each mark.** Discard the pieces that would have been covered by the keeper.

D. **Pinch the corners of the top and bottom** of each piece needed, this will help install the caps easier.

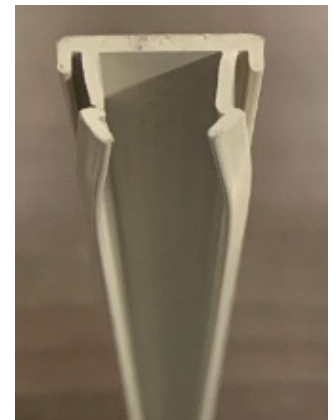
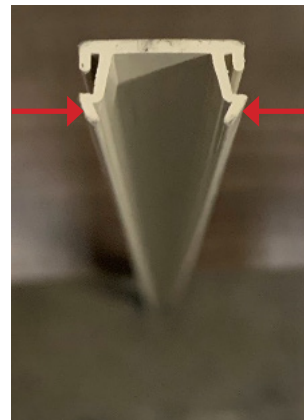

# 10 Strike Side Cap Installation (continued):

E. Install each cut cap piece in the appropriate location on the jamb tucking it behind the keepers.

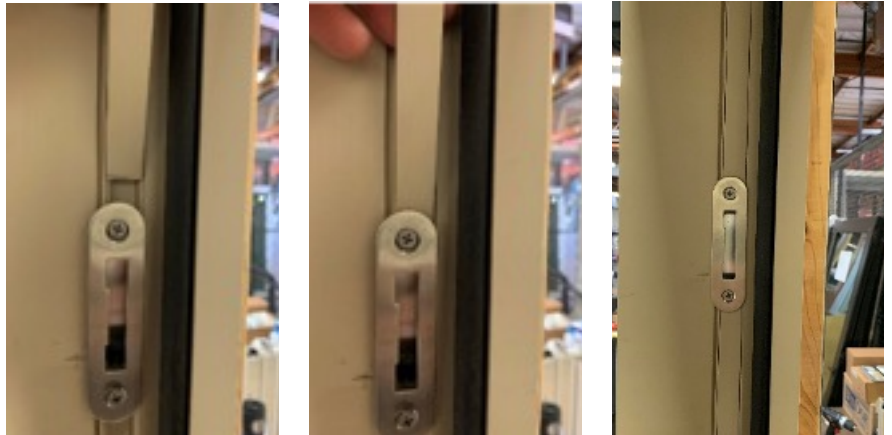

F. Tighten all screws back in place on each keeper.

# 11 Magnet Installation:

A. On the primary active panel, near the jamb, place a square on the bottom of the panel to where the edge of the square is aligned with the edge of the glass and trace that line down.

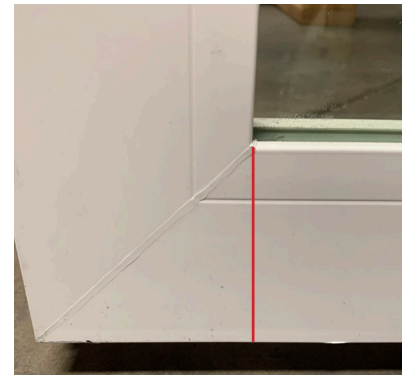

B. Align the housing assembly (angled side facing down) to the drawn line and flush with the bottom of the panel. Pre-drill the holes with a 9/64" bit.



C. Remove the housing and insert the magnet and springs in the housing.





# 11 Magnet Installation (continued):

D. **Compress the housing assembly** back into the same location and secure into place with the provided screws.

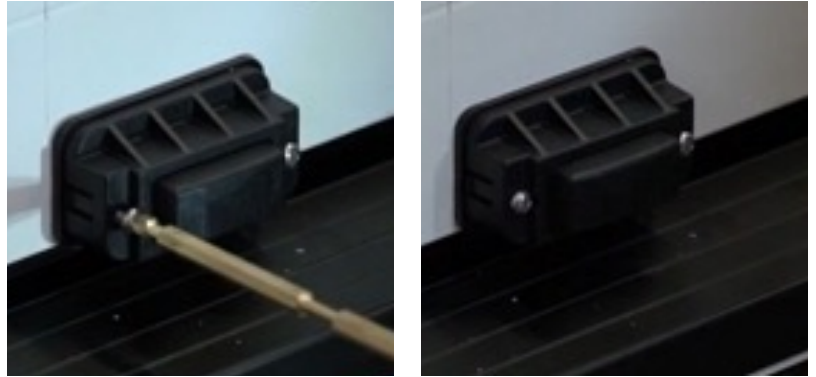

E. **Install the metal covers** over the magnet housing.



Repeat step 11 A-E on the next panel but in the opposite corner.

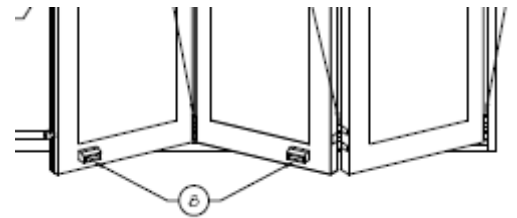

# 12 Hinge Shim Installation:

To make the Folding Door installation easier, we have included hinge shims if needed.

The hinge shim is an easy and reliable tool; shims can help to overcome size variations that can occur within the welding process. Before applying any hinge shims, make sure all proper spacing and alignments have been made to the Folding Door or Folding Window.

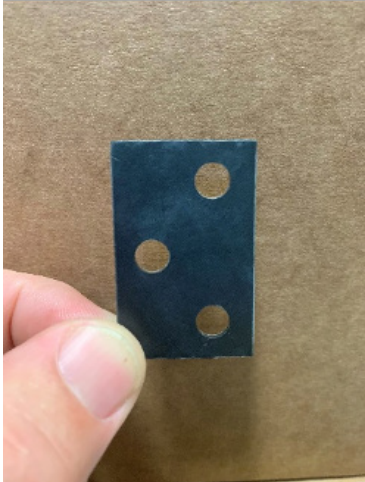

## Hardware with Key Lock

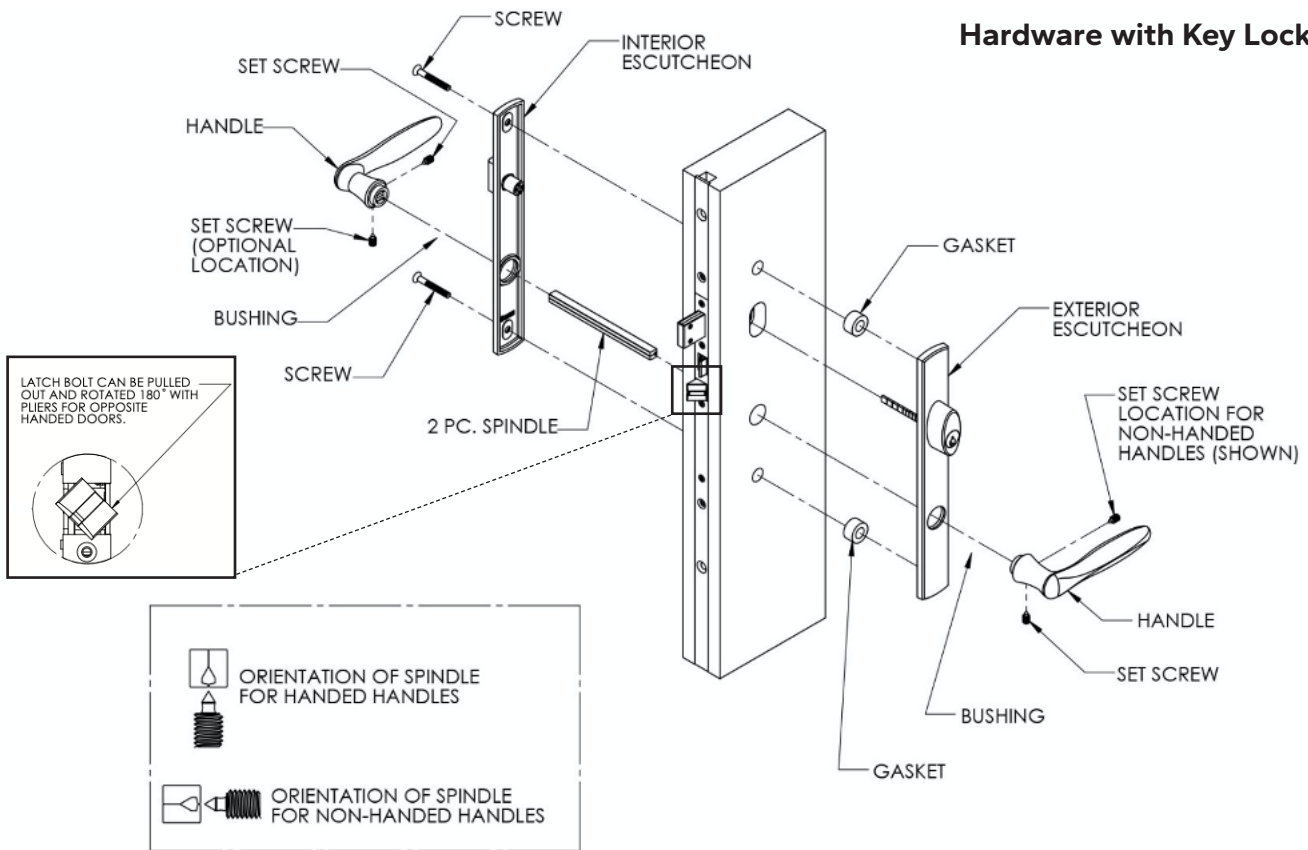

## Hardware without Key Lock

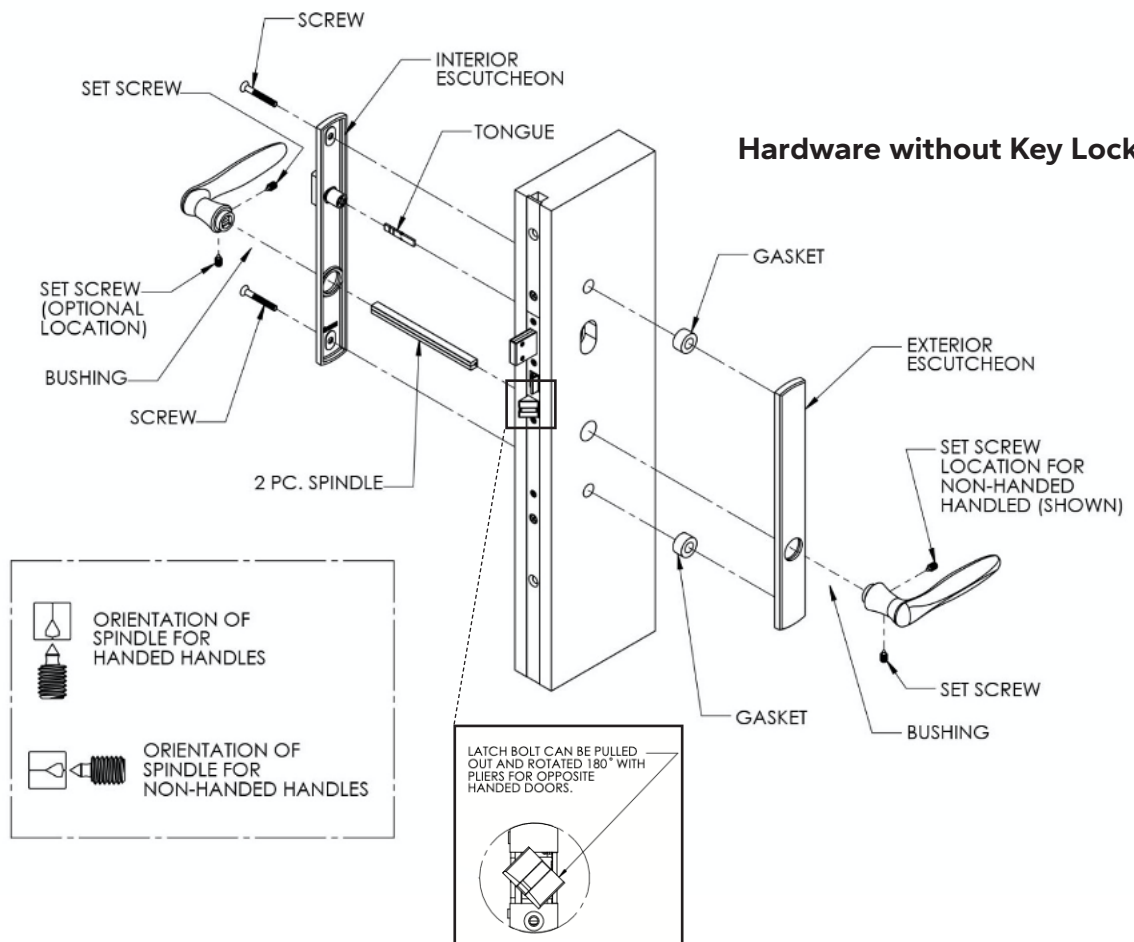



# Frame – Exploded View

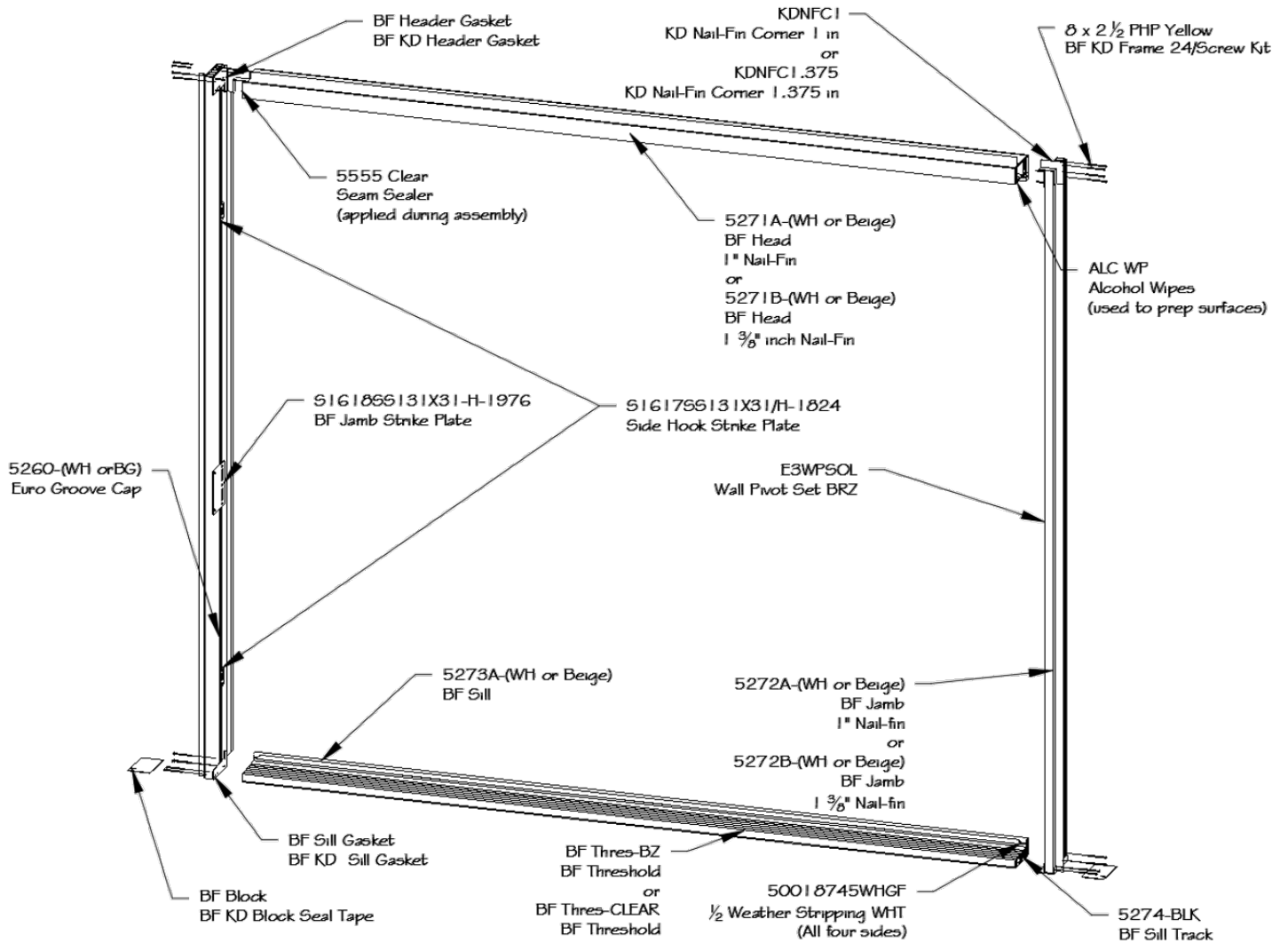

# Frame – Exploded View

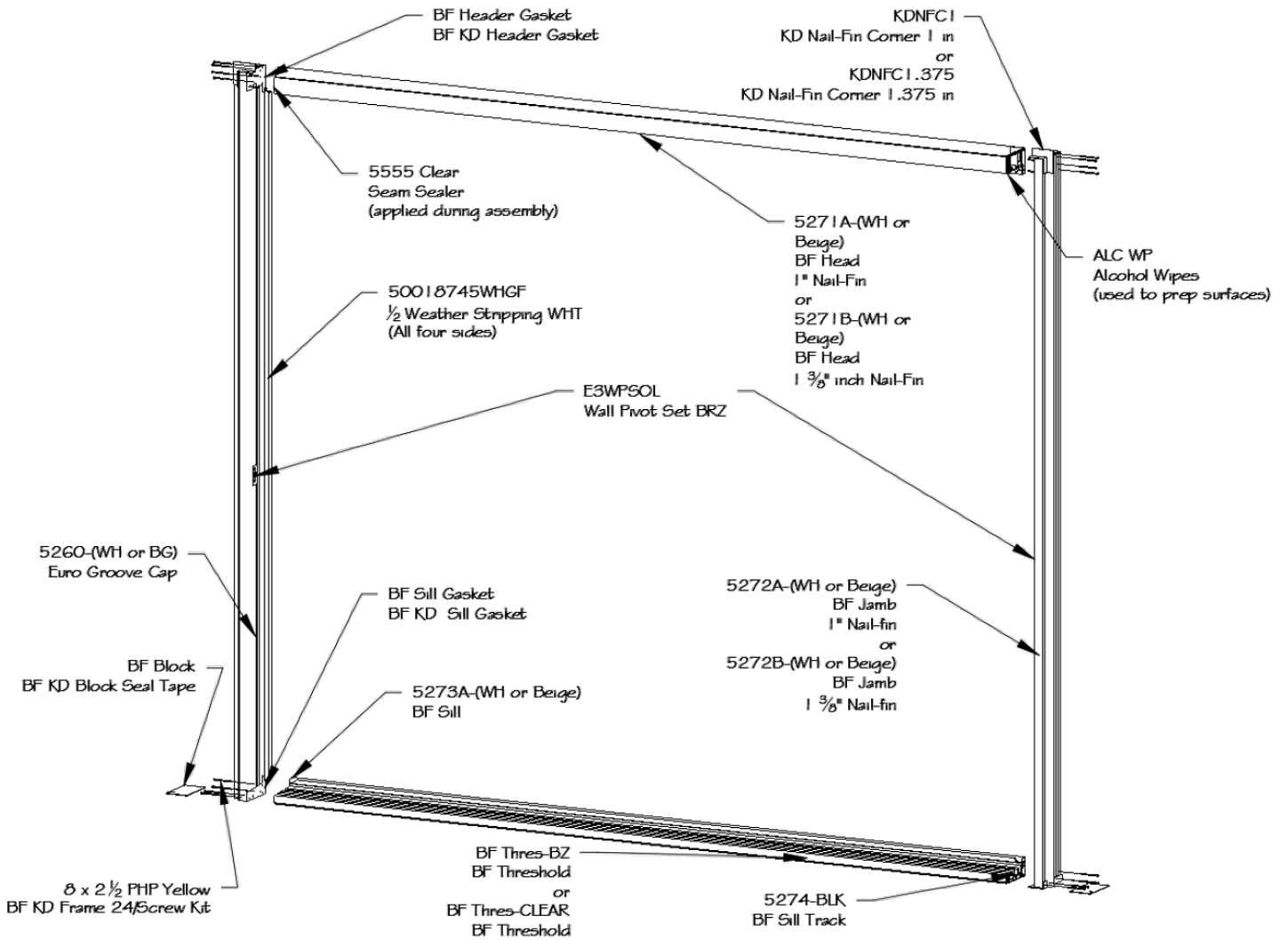

# Sill to Jamb – Exploded View

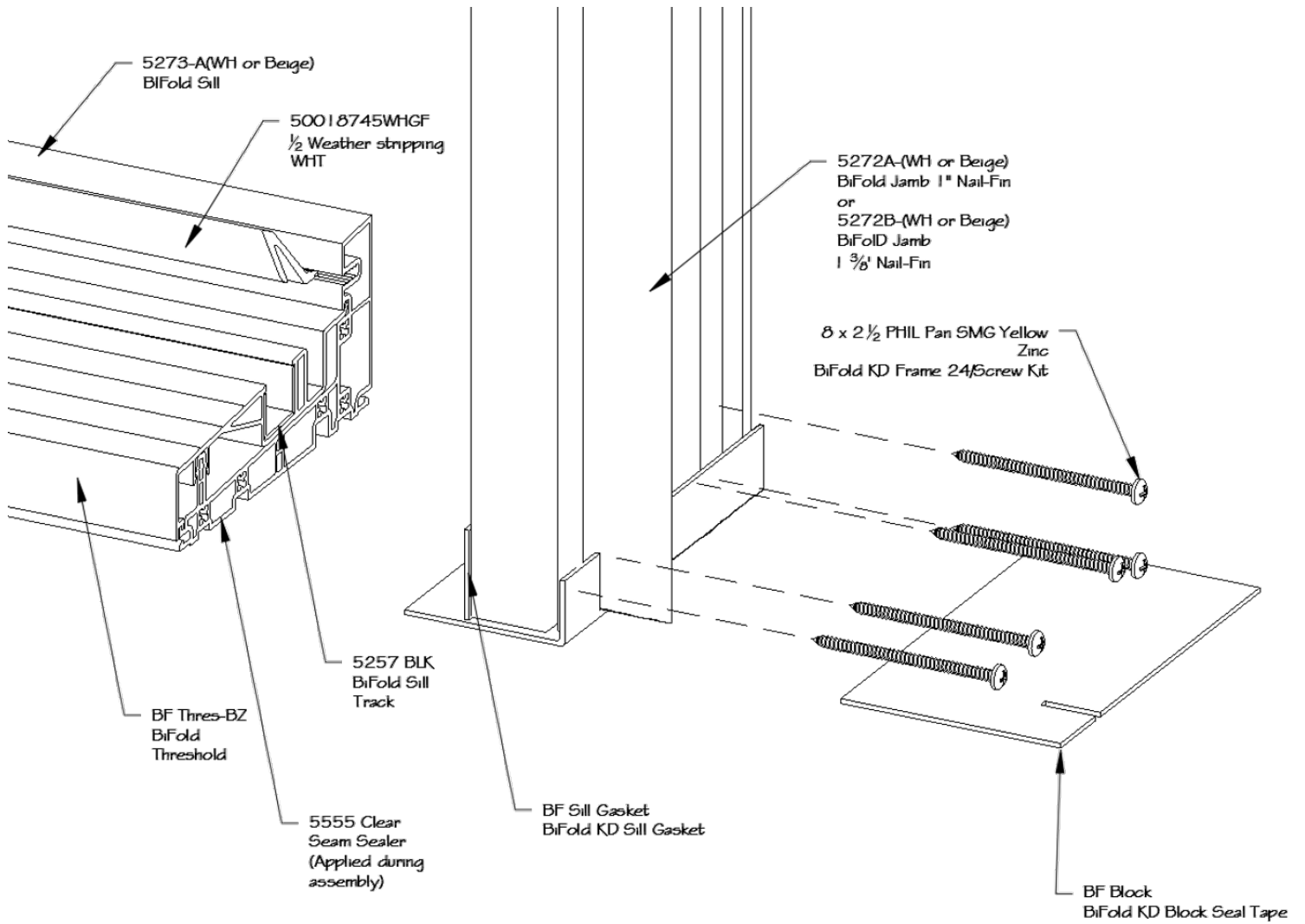



# Head to Jamb – Exploded View

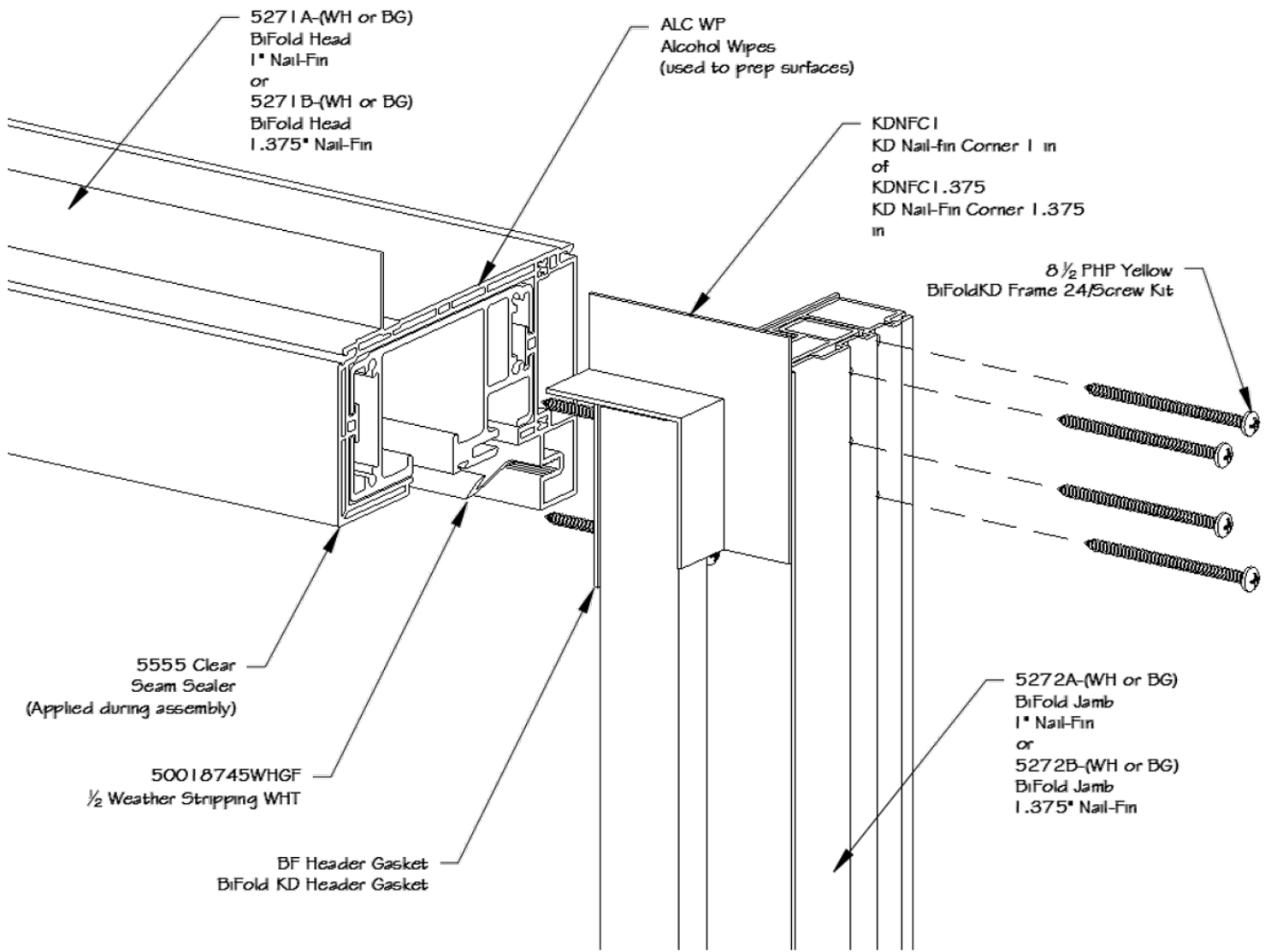



### Interior Sealant Instructions

**CAUTION:** Continuous backer rod (as necessary) and a high quality, low-odor interior sealant such as Pella Window and Door Installation Sealant (or equivalent) is recommended for commercial or high performance installations to create the continuous interior seal. Follow the directions on the cartridge. For standard performance or products with factory applied jamb extensions, use low pressure polyurethane insulating foams. Follow the directions on the can. Do not use high pressure or latex foams. Fiberglass batt or similar insulation is not recommended as it can absorb water and does not act as an air seal.

- Insert the nozzle or straw between the rough opening and door frame from the interior. Use pliers (if necessary) to compress the end of a straw tube to allow it to fit in tight openings.
- Place a 1" deep bead of foam approximately 1" from the interior of the frame to allow for expansion. DO NOT fill the entire depth of the rough opening cavity.

**NOTE:** Apply foam between the frame and rough opening, NOT between jamb extensions and the rough opening.

- Re-check door operation and remove remaining shipping spacers after foam installation. Excess foam may be removed with a serrated knife after it cures.
- To ensure a continuous interior seal, apply sealant over or around any shims or clips interrupting the foam seal.
- Place a continuous bead of sealant across the inner sill at the intersection of the door sill and subfloor. Continue the sealant 6" up each jamb.

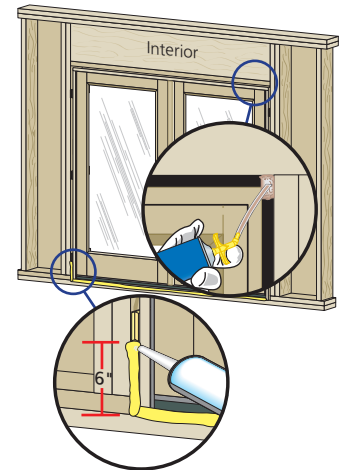

### Exterior Sealant Instructions

**CAUTION:** Use a high quality, multi-purpose exterior sealant such as Pella Window and Door Installation Sealant. Follow the directions on the cartridge.

When applying siding, brick veneer, flashing, or other exterior finish materials, leave adequate space between the door frame and the material for application of sealant.

- Insert backer rod 3/8" deep in the space around the door. Backer rod adds shape and controls the depth of the sealant line.
- Apply a continuous bead of sealant to the entire perimeter of the door.
- Shape, tool and clean excess sealant. When finished, the sealant should be the shape of an hourglass.

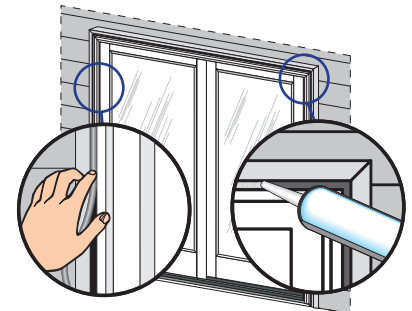



## OPTIONAL SILL PAN INSTRUCTIONS

**NOTICE** The method of pan construction, flashing, and sealant application may vary depending on the design of the opening sill and exterior landing surface conditions. It is important to consider the exposure to weather, the exterior landing surface's proximity to the door sill, and to confirm impervious exterior surfaces properly slope away from the door.

A. **Cut the sill pan** to the width of the rough opening plus 2".

**NOTE: The 2" added onto the rough opening width is for a 1" bend on each end.**

B. **Make a 1" cut** in each fold at both end of the sill pan.

**NOTE: These cuts will allow the edges of the sill pan to be bent.**

C. **Cut 1" off each end** of the interior sill pan lip.

D. **Bend each end** of the center panel up.

E. **Install the sill pan** by sliding into place until the exterior sill pan lip is flush with the exterior of the rough opening.

F. **Apply sill flashing tape.** Cut a piece of flashing tape 2" longer than the opening width. Apply at the bottom of the opening, covering the exterior sill pan lip as shown.

**NOTE: If applicable, apply spray adhesive to building felt prior to applying the flashing tape.**

G. **Cut a piece of flashing tape** to the width of the opening. Install tape to the sill pan and overlap the flashing tape from step 1F by 1". If needed add a second or third piece of flashing tape until the sill pan is covered to the interior sill pan lip.

**NOTE: The purpose of this tape is to seal the sill screws when installing the door.**

H. **Cut two 9" pieces of flashing tape** with a 1" x 3" tab at the bottom, on opposite corners as shown.

I. **Apply the tabbed 9" pieces of flashing tape.** The tape is applied so 2" will cover the inside of the rough opening and lap over the side flange of the sill pan. The 1" x 3" tab laps over the bottom flashing tape as shown.

J. **Cut two 6" pieces of flashing tape** and apply to each side of the rough opening, overlapping the first piece by 1" and lapping the bottom over the side flange of the sill pan as shown.

K. **Cut two pieces of flashing tape 1-1/2" x 6"** and apply to the bottom corners of the opening by beginning in the corner of the sill pan, with 3/4" of the tape applied to the sill pan and 3/4" of the tape applied to the side flange. The remainder of the tape is to be at a 45 degree angle onto the exterior.

L. **Attach the aluminum sill support** or wood blocking to the exterior of the box plate to support the edge of the door sill. Place the sill support flush with the subfloor.

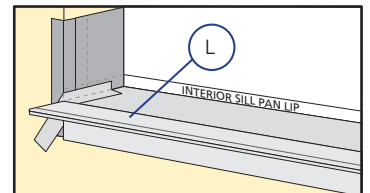
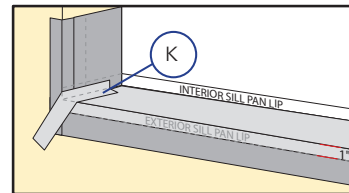
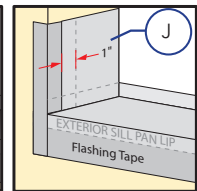
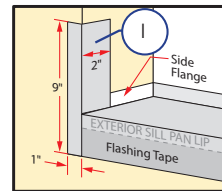
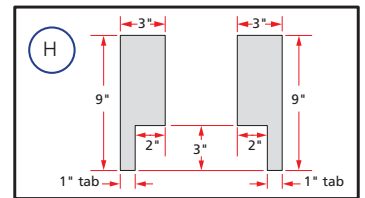
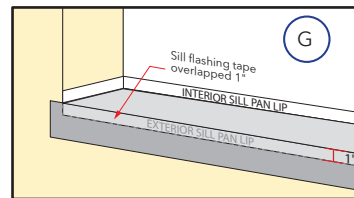
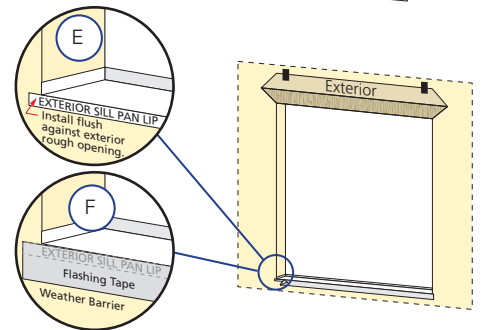
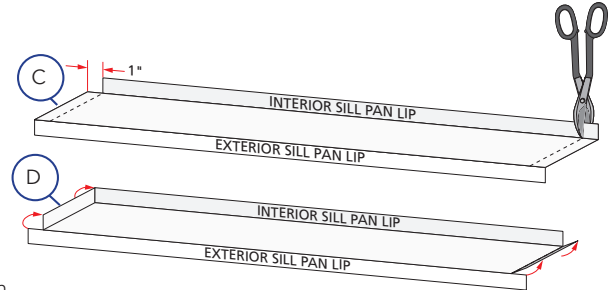
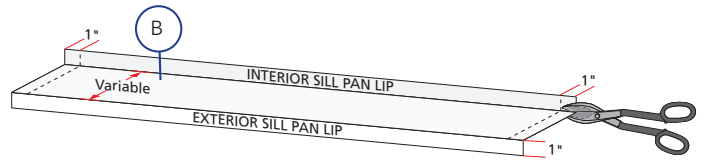

### Concrete Slab (without sill pan) Instructions

**NOTE: Thoroughly clean the slab where sealants will be installed. Instead of installing flashing tape across the bottom of the rough opening, complete the following:**

A. **Install flashing tape at the bottom 6"** of the rough opening jambs.

B. **Cut two 9" pieces of flashing tape** as shown in step 1H above.

C. **Install them overlapping** the flashing tape installed in step A by 1".

D. **Place a 3/8" bead of sealant** where the bottom edge of the flashing tape meets the concrete slab.

E. **When folding building wrap in at the jambs**, cut at a 30 degree angle as illustrated.

Follow the applicable installation method pages to complete the installation except seal the door sill directly to the slab.

